

# i5/OS V5R4 Virtual Tape: A Guide to Planning and Implementation

Discover how i5/OS virtual tape works

Learn how to save and restore  
objects with virtual tape support

Understand how virtual  
tape works with BRMS

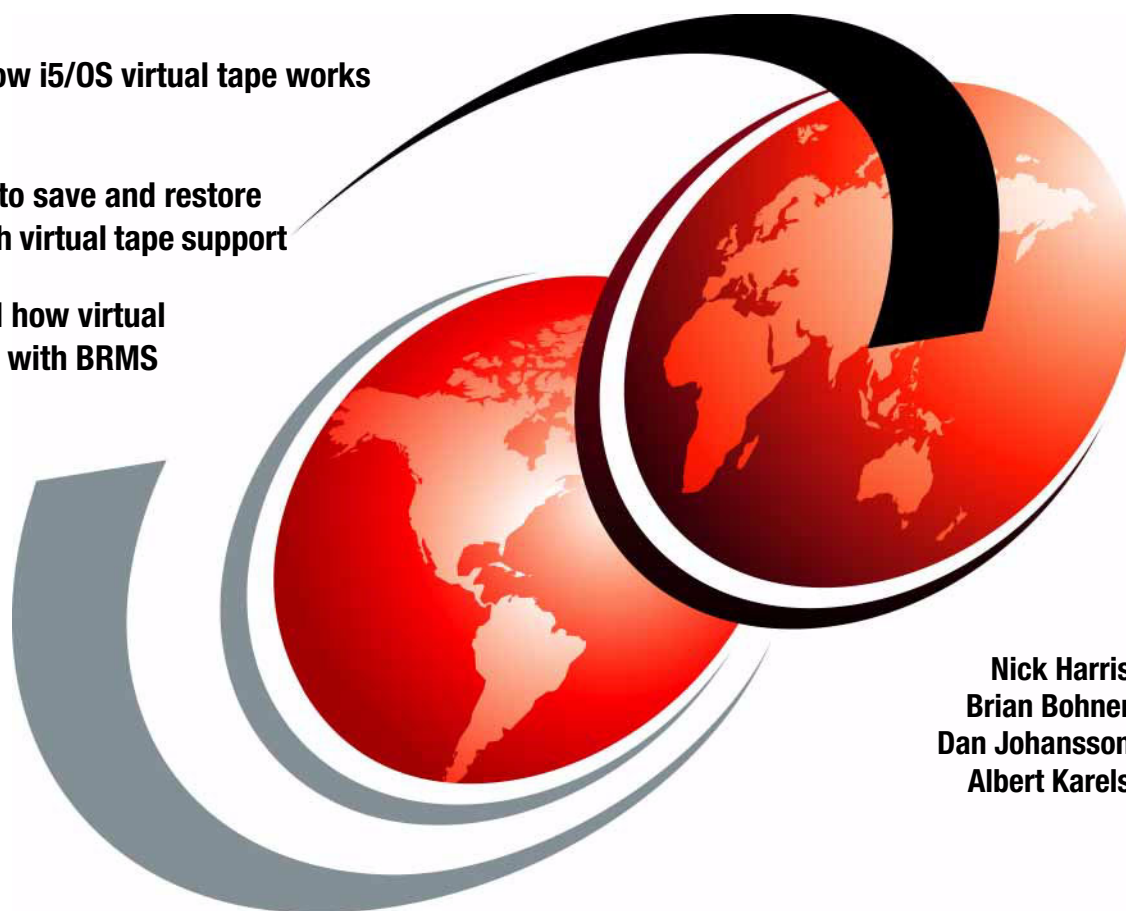

Nick Harris  
Brian Bohner  
Dan Johansson  
Albert Karels





International Technical Support Organization

**i5/OS V5R4 Virtual Tape: A Guide to Planning and  
Implementation**

July 2006

**Note:** Before using this information and the product it supports, read the information in “Notices” on page vii.

**First Edition (July 2006)**

This edition applies to Version 5, Release 4, i5/OS (product number 5722-SS1).

**© Copyright International Business Machines Corporation 2006. All rights reserved.**

Note to U.S. Government Users Restricted Rights -- Use, duplication or disclosure restricted by GSA ADP Schedule Contract with IBM Corp.

# Contents

<b>Notices</b> .....	vii
Trademarks .....	viii
<b>Preface</b> .....	ix
The team that wrote this redbook .....	ix
Become a published author .....	x
Comments welcome .....	xi
<b>Chapter 1. Introduction to virtual tape</b> .....	1
1.1 What is virtual tape .....	2
1.2 Positioning the virtual tape .....	2
1.2.1 Other virtual media services .....	2
1.2.2 Supported applications and operating systems .....	3
1.3 Benefits of virtual tape .....	4
1.4 Supported physical devices .....	5
1.5 More details about virtual tape .....	6
1.5.1 Virtual tape device .....	6
1.5.2 Image catalog .....	6
<b>Chapter 2. Planning for virtual tape</b> .....	9
2.1 What to save through virtual tape .....	10
2.2 Considering the backup strategy .....	10
2.2.1 Backup strategy considerations .....	10
2.2.2 The amount of space needed .....	11
2.3 The ASP to use for virtual tape .....	13
2.3.1 Considering system ASP, user ASP, or iASP for virtual tape .....	14
2.3.2 Preparing to use a user ASP or an iASP .....	16
2.3.3 Using virtual tape volumes in user ASPs .....	17
2.3.4 Using virtual tape in an iASP .....	19
2.4 Performance considerations .....	21
2.5 Requirements .....	22
2.5.1 Operating system requirements .....	22
2.5.2 Hardware requirements .....	23
2.5.3 Resource requirements .....	23
2.5.4 Security requirements .....	25
2.6 Limitations .....	26
2.6.1 Installing i5/OS and related software .....	26
2.6.2 Unsupported commands and functions .....	26
2.6.3 Other limitations .....	27

2.7 Planning for Backup Recovery Media Services .....	27
<b>Chapter 3. Implementing virtual tape storage .....</b>	<b>33</b>
3.1 Setting up virtual tape storage.....	34
3.2 Using a tape image catalog.....	58
3.2.1 Save using a tape image catalog .....	61
3.2.2 Automatic creation of new volumes .....	65
3.2.3 Viewing the virtual volumes.....	67
3.2.4 Changing virtual media characteristics .....	79
3.3 Copying virtual tape to physical tape.....	89
3.3.1 Preparing for duplication .....	90
3.3.2 Duplicating virtual tape to physical tape .....	102
3.3.3 Saving virtual tape as an object .....	112
3.4 Catalog shadowing .....	120
3.4.1 Overview of catalog shadowing .....	120
3.4.2 Setting up image catalog shadowing .....	124
3.4.3 Utilizing dependent catalogs .....	132
3.4.4 Removing a shadowed volume.....	133
3.4.5 Deleting a shadowed catalog .....	135
<b>Chapter 4. Multiple virtual tape scenarios .....</b>	<b>141</b>
4.1 Nightly backup using virtual tape.....	142
4.1.1 Preparing for nightly backup .....	142
4.1.2 Performing the nightly backup.....	143
4.2 BRMS parallel backup.....	148
4.2.1 Parallel-parallel scenario.....	149
4.2.2 Parallel-serial backup .....	161
4.3 SAVSYS using virtual tape .....	174
4.3.1 Preparing for SAVSYS .....	175
4.3.2 Performing SAVSYS.....	176
4.3.3 Duplicating virtual volumes .....	182
4.3.4 Summary.....	187
<b>Chapter 5. Saving Domino with BRMS and virtual tape .....</b>	<b>189</b>
5.1 Creating the image catalog .....	190
5.2 Creating a BRMS backup policy for Domino.....	202
5.3 Creating a move policy .....	230
5.3.1 Creating a move policy for virtual volumes .....	231
5.3.2 Adjusting the virtual move policy.....	239
5.3.3 Creating a move policy for physical volumes .....	241
5.4 Adjusting the backup policy.....	242
5.5 Running the Domino backup.....	250
5.5.1 Checking the results .....	254
5.6 Restoring a mail file.....	262

5.6.1	Checking the results	276
<b>Chapter 6.</b>	<b>BRMS and virtual tape</b>	<b>279</b>
6.1	Implementing BRMS using 5250 emulation	280
6.2	Setting up virtual tape	280
6.3	Installing BRMS	281
6.4	Setting up locations in BRMS for virtual tape	283
6.4.1	Location considerations in BRMS	284
6.4.2	Setting up virtual devices in BRMS	287
6.4.3	Creating virtual media classes	289
6.4.4	Creating move policies	294
6.4.5	Creating media policies	297
6.4.6	Creating the link list	301
6.4.7	Creating control groups for daily backup of user data	304
6.4.8	Running the daily backup	310
6.4.9	Duplicating media	313
6.4.10	Running media movement	319
6.5	BRMS maintenance	320
<b>Chapter 7.</b>	<b>BRMS and virtual tape working from the Navigator</b>	<b>329</b>
7.1	BRMS and a brief introduction to virtual tape	330
7.1.1	Setting up locations	331
7.2	Defining a move policy	335
7.2.1	Creating a move policy	336
7.2.2	Move policy for physical tape volumes	344
7.3	Designing a tailored backup policy	344
7.4	Tailoring a backup policy to specific requirements	364
7.4.1	The Before activities	365
7.4.2	The During activities	369
7.4.3	The After activities	376
7.5	Adding media to BRMS	378
7.6	Running the backup	385
7.7	Restoring an object	389
7.7.1	Determining whether the restore worked	402
7.8	Duplicating volumes	408
7.8.1	Adding physical tape volumes	408
7.8.2	Duplicating volumes	415
7.9	Parameters available only from Navigator	422
7.10	Adding a new tape drive to BRMS	427
7.11	Reinstating dialog boxes	429
<b>Chapter 8.</b>	<b>Debugging examples using the GUI</b>	<b>431</b>
8.1	First attempt	432
8.2	Second attempt	440

8.3 The final attempt . . . . .	445
<b>Appendix A. Block sizes</b> . . . . .	457
Block size chart . . . . .	458
<b>Appendix B. Sample command language</b> . . . . .	461
How command language program works . . . . .	462
Command language sample source . . . . .	462
Command source to use with the command language . . . . .	466
Command options . . . . .	467
<b>Appendix C. Quick start guide</b> . . . . .	471
Setting up virtual tape . . . . .	472
Setting up virtual tape through iSeries Navigator . . . . .	472
Setting up virtual tape through 5250 emulation . . . . .	473
Additional steps for BRMS . . . . .	474
<b>Related publications</b> . . . . .	477
IBM Redbooks . . . . .	477
Other publications . . . . .	477
Online resources . . . . .	477
How to get IBM Redbooks . . . . .	478
Help from IBM . . . . .	478
<b>Index</b> . . . . .	479

# Notices

This information was developed for products and services offered in the U.S.A.

IBM may not offer the products, services, or features discussed in this document in other countries. Consult your local IBM representative for information on the products and services currently available in your area. Any reference to an IBM product, program, or service is not intended to state or imply that only that IBM product, program, or service may be used. Any functionally equivalent product, program, or service that does not infringe any IBM intellectual property right may be used instead. However, it is the user's responsibility to evaluate and verify the operation of any non-IBM product, program, or service.

IBM may have patents or pending patent applications covering subject matter described in this document. The furnishing of this document does not give you any license to these patents. You can send license inquiries, in writing, to:  
*IBM Director of Licensing, IBM Corporation, North Castle Drive Armonk, NY 10504-1785 U.S.A.*

*The following paragraph does not apply to the United Kingdom or any other country where such provisions are inconsistent with local law.* INTERNATIONAL BUSINESS MACHINES CORPORATION PROVIDES THIS PUBLICATION "AS IS" WITHOUT WARRANTY OF ANY KIND, EITHER EXPRESS OR IMPLIED, INCLUDING, BUT NOT LIMITED TO, THE IMPLIED WARRANTIES OF NON-INFRINGEMENT, MERCHANTABILITY OR FITNESS FOR A PARTICULAR PURPOSE. Some states do not allow disclaimer of express or implied warranties in certain transactions, therefore, this statement may not apply to you.

This information could include technical inaccuracies or typographical errors. Changes are periodically made to the information herein; these changes will be incorporated in new editions of the publication. IBM may make improvements and/or changes in the product(s) and/or the program(s) described in this publication at any time without notice.

Any references in this information to non-IBM Web sites are provided for convenience only and do not in any manner serve as an endorsement of those Web sites. The materials at those Web sites are not part of the materials for this IBM product and use of those Web sites is at your own risk.

IBM may use or distribute any of the information you supply in any way it believes appropriate without incurring any obligation to you.

Information concerning non-IBM products was obtained from the suppliers of those products, their published announcements or other publicly available sources. IBM has not tested those products and cannot confirm the accuracy of performance, compatibility or any other claims related to non-IBM products. Questions on the capabilities of non-IBM products should be addressed to the suppliers of those products.

This information contains examples of data and reports used in daily business operations. To illustrate them as completely as possible, the examples include the names of individuals, companies, brands, and products. All of these names are fictitious and any similarity to the names and addresses used by an actual business enterprise is entirely coincidental.

## COPYRIGHT LICENSE:

This information contains sample application programs in source language, which illustrates programming techniques on various operating platforms. You may copy, modify, and distribute these sample programs in any form without payment to IBM, for the purposes of developing, using, marketing or distributing application programs conforming to the application programming interface for the operating platform for which the sample programs are written. These examples have not been thoroughly tested under all conditions. IBM, therefore, cannot guarantee or imply reliability, serviceability, or function of these programs. You may copy, modify, and distribute these sample programs in any form without payment to IBM for the purposes of developing, using, marketing, or distributing application programs conforming to IBM's application programming interfaces.

# Trademarks

The following terms are trademarks of the International Business Machines Corporation in the United States, other countries, or both:

@server®  
@server®  
eServer™  
AS/400®  
Domino®  
iSeries™  
i5/OS®

IBM®  
Lotus®  
NetServer™  
OS/400®  
PAL™  
Redbooks™  
Redbooks (logo) ™

System i5™  
System/36™  
System/38™  
Tivoli®  
xSeries®  
z/OS®

The following terms are trademarks of other companies:

Windows, and the Windows logo are trademarks of Microsoft Corporation in the United States, other countries, or both.

Linux is a trademark of Linus Torvalds in the United States, other countries, or both.

Other company, product, or service names may be trademarks or service marks of others.

# Preface

In this IBM® Redbook we provide a detailed explanation of the new virtual tape support provided by i5/OS® V5R4. We cover the concepts, planning, and use of virtual tape support.

Backup and Recovery Media Services (BRMS) is an important program product for System i5™ customers to enable management of their system and data backups. This publication describes how BRMS uses the new virtual tape support for virtual backups.

This redbook is intended for IBM, Business Partner and client technical professionals who will be planning, implementing, and operating virtual tape support.

## The team that wrote this redbook

This redbook was produced by a team of specialists from around the world working at the International Technical Support Organization, Rochester Center.

**Nick Harris** is a Consulting IT Specialist for the iSeries™ and has spent the last eight years in the International Technical Support Organization, Rochester Center. He specializes in eServer™ i5 and iSeries hardware, i5/OS and OS/400® software, LPAR, High Availability, external disk, Windows® integration, and Linux®. He writes IBM Redbooks™ and teaches IBM classes at ITSO Technical forums worldwide on all these areas and as they are related to system design and server consolidation. He spent 13 years in the United Kingdom (UK) AS/400® Business, where he worked with S/36, S/38, AS/400, and iSeries servers.

You can contact Nick by sending e-mail to:

<mailto:niharris@us.ibm.com>

**Brian Bohner** is a Software Engineer for the IBM Rochester iSeries Support Center, Rochester, MN. He has been a specialist on the Save/Restore and BRMS team since 2001. His areas of expertise include upgrades, backups, recoveries, PTFs, BRMS, and virtual media. Brian has authored several technical documents including an article that first introduced Image Catalogs which was published in the eServer iSeries magazine. He continues to provide remote technical support, future release functions/support, and lab testing, and travels

nationally and internationally to perform system installations and disaster recovery.

You can contact Brian by sending e-mail to:

<mailto:bbohner@us.ibm.com>

**Dan Johansson** is a Software Specialist working in Information Technology Services for IBM Sweden. He specializes in software support for System i5, i5/OS, OS/400 and BRMS.

You can contact Dan by sending e-mail to:

<mailto:dan.johansson@se.ibm.com>

**Albert Karels** is an IT Specialist Advisory in IBM The Netherlands. He has worked at IBM for 17 years. In 1997 he joined the iSeries software support team in the Netherlands, where he still works today. His areas of expertise include BRMS, save&restore and tape support on iSeries.

You can contact Albert by sending e-mail to:

[mailto:albert\\_karels@nl.ibm.com](mailto:albert_karels@nl.ibm.com)

Thanks to the following for their contributions to this project:

Joe Kochan

Sanjay A Patel

Lee Prissel

IBM Rochester Development Lab

Mervyn Venter

IBM Rochester Support Center

Debbie Saugen

IBM Business Continuity and Recovery Services

## Become a published author

Join us for a two- to six-week residency program! Help write an IBM Redbook dealing with specific products or solutions, while getting hands-on experience with leading-edge technologies. You'll team with IBM technical professionals, Business Partners and/or customers.

Your efforts will help increase product acceptance and customer satisfaction. As a bonus, you'll develop a network of contacts in IBM development labs, and increase your productivity and marketability.

Find out more about the residency program, browse the residency index, and apply online at:

[ibm.com/redbooks/residencies.html](http://ibm.com/redbooks/residencies.html)

## Comments welcome

Your comments are important to us!

We want our Redbooks to be as helpful as possible. Send us your comments about this or other Redbooks in one of the following ways:

- ▶ Use the online **Contact us** review redbook form found at:

[ibm.com/redbooks](http://ibm.com/redbooks)

- ▶ Send your comments in an e-mail to:

[redbook@us.ibm.com](mailto:redbook@us.ibm.com)

- ▶ Mail your comments to:

IBM Corporation, International Technical Support Organization  
Dept. HYTD Mail Station P099  
2455 South Road  
Poughkeepsie, NY 12601-5400





# Introduction to virtual tape

In this chapter, we introduce virtual tape in i5/OS. First we explain the virtual tape concept and describe how to position it. Next, we compare virtual tape with physical tape and discuss the benefits of using virtual tape.

Finally, we describe the physical devices that are supported, and how virtual tape actually works.

## 1.1 What is virtual tape

The virtual tape concept is a simulated tape environment within i5/OS. It consists of the following:

- ▶ Virtual tape drives (up to 35)
- ▶ Virtual tapes (256 maximum per image catalog)
- ▶ One or more image catalogs holding the virtual tapes. These are called *image catalog entries*.

This virtual environment behaves exactly as though there were real tape drives with real physical tape volumes. The virtual tape volumes are structured exactly like real tapes, with headers, tape marks, trailer labels, and so on.

Use virtual tapes exactly as you would real tapes. Commands such as DSPTAP, CHKTAP, and so on behave in the same manner as they would in real tapes. As a user you will not notice any difference. You can even flip their write protect switch.

Notice the emphasis on the word “exact”. This is because virtual tapes are *exactly* like real tapes, with only a minor difference: since they are virtual, you should copy the virtual tapes to real tape volumes and store them safely. Apart from this, no other difference exists.

## 1.2 Positioning the virtual tape

This section discusses the positioning of virtual tape and compares it with other virtual media services and physical tape.

### 1.2.1 Other virtual media services

The following virtual media services are available:

- ▶ Virtual optical

This is available in OS/400 V5R2, i5/OS V5R4, and subsequent releases. With this function, you can load optical images and use them for installation of software and PTFs.
- ▶ Virtual Tape Server (VTS)

This is currently *not* available in i5/OS. This function, which is actually a tape server on which clients can back up their details, is available on some other platforms (for example, the IBM z/OS® platform).

- ▶ Virtual tape

This is available in i5/OS V5R4 and subsequent releases, and can be used to back up and restore data from a virtual tape device.

## 1.2.2 Supported applications and operating systems

The virtual tape function in i5/OS provides the same functionality as a physical tape. There are, however, a few exceptions with regard to specific functions. These are discussed in 2.6, “Limitations” on page 26.

Virtual tape in i5/OS acts as a Random Access Cartridge Loader (RACL), which is still a tape device and not a media library. All the save commands in i5/OS can use the virtual tape function.

The following applications and integrated operating systems are supported:

- ▶ Backup Recovery and Media Services (BRMS)

BRMS V5R4 fully supports virtual tape. 2.7, “Planning for Backup Recovery Media Services” on page 27 provides more information about BRMS and virtual tape.

- ▶ Linux on integrated IBM @server® xSeries® server

For more information about Linux and virtual tape, refer to the IBM @server iSeries Information Center, which is available on the Web at:

<http://publib.boulder.ibm.com/infocenter/iseries/v5r4/index.jsp>

In the Contents frame on the left panel, select **iSeries Information Center Version 5 Release 4**, expand **Integrated operating environments**, and select **Linux** → **Linux on an integrated xSeries solution**.

- ▶ Windows on an integrated IBM @server xSeries server

Only the xSeries servers connected through the new V5R4 iSCSI support can use virtual tape. There is no support for xSeries servers connected via HSL.

- ▶ System i5 guest operating system support:

Linux in a guest partition on i5 using virtual I/O (hosted). Currently, there is no support for AIX®.

## 1.3 Benefits of virtual tape

Using virtual tape offers the following benefits:

- ▶ There is no need for physical tape devices to be attached during backup or restore.

This can be due to one or more of the following reasons:

- The tape device or media library is shared between systems or partitions.
- The tape device or media library is being used by another process or job at that time.
- The tape device or media library is unavailable or is unstable due to a hardware defect.

Of course, the virtual media still has to be *duplicated* to physical media, but the backup can go on.

- ▶ Virtual tape can be used to reduce backup time by running concurrent backups in situations where there are insufficient physical tape devices available to perform this task.
- ▶ You can FTP the image to other partitions or systems and add it as an entry to the image catalog. There can be multiple reasons why you want the virtual tape image on another system or partition, including the following:
  - In the system on which you are running a backup or restore, there is no hardware to support the media you use for backup. In such a situation, you can back up to virtual tape and then transfer the image to a partition or system to which a physical tape device is attached.
  - You want to restore data from an image on another system and you do not use a switchable iASP to store the virtual tape images on. The image can be used in either switchable iASP or user ASP.

For user ASP and non-switchable iASP, the only benefit is that the user ASP or iASP are on other DASDs. For switchable iASP, the image can be used for backup and restore on multiple systems, without requiring the image to be transferred to another system. You can simply switch the iASP.

- ▶ It can reduce the save time, depending on the configuration and workload.
- ▶ There are no media errors with virtual tape.

A permanent media error causes a backup to fail, which implies that there is no complete backup.

- ▶ The concept of failed saves when using Save-While-Active (SWA) is no longer present.

When performing a backup to physical tape, there is always a chance of a media error and with SWA checkpoint processing, there is no possibility of

restarting the backup since the applications or batch jobs are already running. With virtual tape, this is no longer a concern.

- ▶ It can reduce recovery time, especially in the case of applications in which it is common practice to restore files frequently. For example, for restoring mail files in Domino®, you can restore the files directly from the virtual volumes.
- ▶ It allows having a local copy of data and an offsite duplicated copy of the data. Local copies can be retained on the system for a period of time for recall of the data.
- ▶ It has the ability to save more than one library, while a user without BRMS can only save one library per save file.

## 1.4 Supported physical devices

Virtual tape on i5/OS supports every physical tape device that is supported on i5/OS. However, there are four different densities you can choose for virtual tape, and the density should be compatible with the physical device.

For virtual tape, density is used to control the optimum block size that the volume will use. Following are the four densities available for virtual tape:

- ▶ \*VRT32K

This will not use an optimum block size and will be compatible with all physical devices.

- ▶ \*VRT64K

This uses an optimum block size of 64 KB and will be compatible with 3490F model 18 track media, VXA, 8 mm devices, 35xx devices, and newer type QIC devices.

- ▶ \*VRT240K

This uses an optimum block size of 240 KB and will be compatible with VXA, 8 mm devices, 35xx devices, and newer type QIC devices.

- ▶ \*VRT256K

This uses an optimum block size of 256 KB and will be compatible with 35xx devices and newer type QIC devices.

Appendix A, “Block sizes” on page 457 contains a chart with a list of physical devices and their compatibility with block size.

For maximum performance, use the largest compatible block size. The density can only be changed with the INZTAP command.

**Note:** A backup performed on a volume with a density that is not compatible with the physical device cannot be duplicated.

## 1.5 More details about virtual tape

This section provides more information about how virtual tape actually works.

### 1.5.1 Virtual tape device

A virtual tape device acts as a real tape device. It uses the same technology used by virtual optical devices, such as an image catalog and image catalog entries. The following specifications apply to virtual tape:

- ▶ Every system with V5R4 or a subsequent release installed has an IOP type 268C with a storage controller (IOA) type 6B02. These are the virtual IOPs and IOAs to which the virtual devices will be attached.
- ▶ The virtual tape device resources have a type 63B0 and will automatically be created when a virtual tape device description is created specifying \*VRT as the hardware resource.
- ▶ You can create as many virtual tape device descriptions as you want, but the maximum number of virtual tape resources is 35. Therefore, there can be up to 35 virtual tape devices being varied on at same time.
- ▶ Virtual tape resources (type 63B0) will have a status of NOT DETECTED in WRKHDWRSC or DSPHDWRSC after the next IPL, when no device description is attached. There is no need to delete this hardware resource.

### 1.5.2 Image catalog

Virtual tape uses the same technology as virtual optical on i5/OS. It also uses an image catalog with image catalog entries. The properties of the image catalog for virtual tape are:

- ▶ An image catalog is an object of type \*IMGCLG and resides in QUSRSYS.
- ▶ When creating the image catalog, a directory in the Integrated File System (IFS) must be specified, in which the virtual volumes will be stored.
- ▶ An image catalog must be loaded. Specify a virtual tape device before using it. The virtual tape device should be varied on.
- ▶ One image catalog can hold up to 256 virtual volumes.
- ▶ Different density types within one image catalog are allowed.

## Image catalog entries

Image catalog entries in an image catalog represent the virtual tape volumes.

The following specifications apply:

- ▶ An image catalog entry is actually a streamfile in IFS residing in the directory specified for the image catalog. This streamfile has a special attribute to prevent the following:
  - Save with storage free
  - Scan processing (virus checking)
  - Journaling
- ▶ The maximum size of one image catalog entry (virtual volume) is 1000,000,000,000 bytes (1TB).
- ▶ It can be stored in iASPs or user ASPs.
- ▶ Virtual volumes can be write protected.





## Planning for virtual tape

Before using virtual tape, it is important to formulate a plan and have a clear understanding of what you require. In this chapter we discuss planning for virtual tape in an enterprise environment. The intention is to provide a clear understanding of the requirements, limitations, and characteristics of virtual tape in order to effectively plan for a new backup and restore strategy.

First we describe what you should save through virtual tape. Next, we discuss backup strategy and space considerations. We explain the various ASP types, and examine performance considerations.

Operating system, hardware, resource, and security requirements are detailed here, as well as the limitations of using virtual tape. Finally, we close the chapter with a discussion of planning for Backup Recovery Media Services (BRMS).

## 2.1 What to save through virtual tape

When considering using virtual tape rather than physical tape directly, you should, based on the backup strategy, determine which objects can be saved to tape and how much storage this requires.

Every object that can be saved today to physical tape can also be saved to virtual tape. There are no restrictions to saving objects on virtual tape. However, there are restrictions with regard to restoring directly from virtual tape; for more information about this topic see 2.6, “Limitations” on page 26.

**Note:** Installation of SLIC or base i5/OS is not possible from virtual tape.

## 2.2 Considering the backup strategy

Before determining how much space you require and whether you want to use a user ASP or iASP, review your backup strategy, since the new backup strategy has to include virtual tape.

### 2.2.1 Backup strategy considerations

To review or create a new backup strategy, consider the following:

- ▶ Determine what you want to save.
- ▶ Determine how often you want it to be saved.
- ▶ Determine how much storage space you have on your disk.
- ▶ Do you want to have a copy in your system location?

If you already have a copy in your tape library, you can decide to keep a copy on the system, rather than keeping a copy on the physical volume in the tape library.

- ▶ Determine how much space is required for virtual tape backup.

Physical tapes offer the benefit of hardware compression, while virtual tapes do not and little compressed is performed. Therefore, backup to virtual tapes may take up more space than backup to physical tapes.

For more information about backup strategy, refer to the IBM @server iSeries Information Center. In the Contents frame on the left side, select **iSeries Information Center Version 5 Release 4**, expand **Systems management**, and select **Backup and recovery** → **Plan a backup and recovery strategy**.

This information can also be accessed on the Web at:

<http://publib.boulder.ibm.com/infocenter/iseriess/v5r4/index.jsp>

Although the backup strategy is related to your environment, and different backup strategies are possible, a simple backup strategy that is modified to include virtual tape is shown in Figure 2-1.

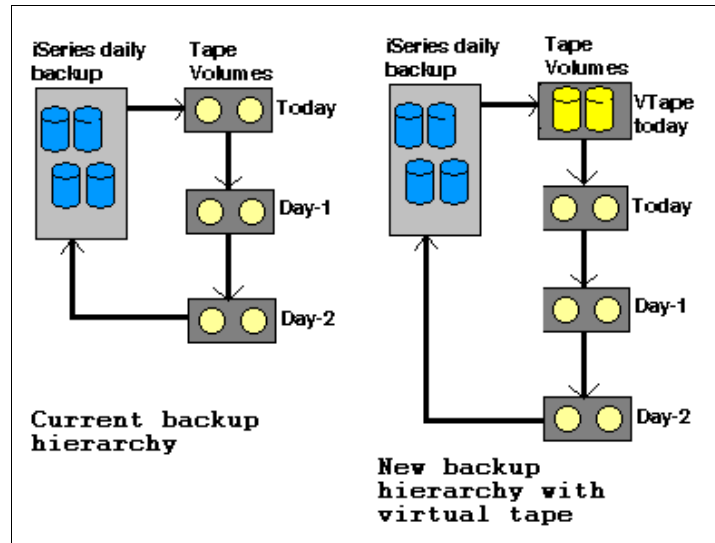

Figure 2-1 Example of backup without and with virtual tape

After the new backup strategy is created, determine the space required for the backups.

## 2.2.2 The amount of space needed

Since virtual images are stored on your disk units, they can use disk space quickly. Ensure that enough disk space is available. While the smallest allowable size for a tape image file volume is 48 MB, the largest allowable size is 1,000,000 MB.

### Determining the disk space you have

To determine how much disk space you have, follow these steps:

1. In IBM @server iSeries Navigator, expand **My Connections** → **your iSeries server** → **Configuration and Service** → **Hardware** → **Disk Units** → **Disk Pools**.

You will be prompted for a service tools user ID and password. Ask your system administrator to provide you with a valid user ID and password.

2. Right-click the **Disk Pool** you want to view, and select **Properties**.
3. Select the **Capacity** tab. The Capacity page displays the used space, free space, total capacity, threshold, and percentage of disk space used for the disk pool.

**Note:** Disk usage for systems with a total disk capacity up to 100 GB is limited to 95% of the capacity for virtual tape operation. The virtual tape operation will stop with an end of media error when 95% of the disk capacity is reached.

For systems with a disk capacity above 100 GB, the tape operation will stop when less than 5 GB disk space is remaining.

4. In the screen capture command line, type the following commands:

```
WRKDSKSTS for disk information
```

or

```
WRKSYSSTS and for general system information
```

### **The number of volumes of virtual images required**

To determine how many volumes you require, consider the following:

- ▶ The amount of data you plan to store
- ▶ The size of each virtual image

Determine the image size based on what you plan to do with the tape image file. Keep the files small if you want to electronically transfer them to another system. Large images will make it inflexible and there is no need to create images of a size equal to the physical volumes, since you can always append data during duplication to physical media.

**Note on CHGATR:** The virtual volumes are actually streamfiles in IFS, as described in “Image catalog entries” on page 7. When saving IFS data, these streamfiles should be omitted from the backup.

However, you can change the attributes of the directory where the virtual images reside and change the “Can be saved” option to \*NO. Following is the command syntax for changing the attribute:

```
CHGATR OBJ('/MyCatalogDirectory') ATR(*ALWSAV) VALUE(*NO) SUBTREE(*ALL)
```

## 2.3 The ASP to use for virtual tape

You can use a system ASP, a user ASP, or an iASP to store your virtual tape images on. From a performance point of view, a user ASP or iASP may be a good option.

If you also want to use the virtual volumes on other systems for restore, a switchable iASP is a good option.

Assume you have the ASPs shown in Figure 2-2, with enough disks and disk arms.

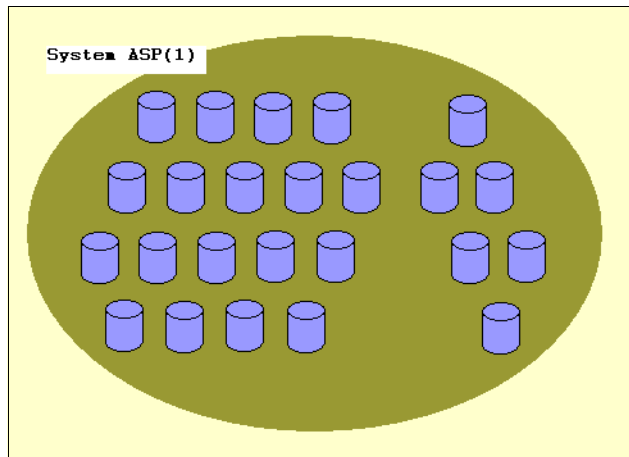

Figure 2-2 System ASP(1)

You decide to reserve disks for another ASP, as shown in Figure 2-3.

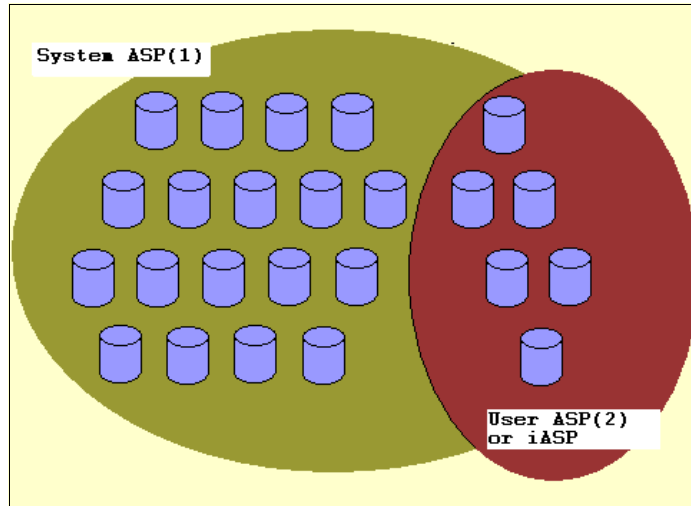

Figure 2-3 System ASP(1) with user ASP or iASP

### 2.3.1 Considering system ASP, user ASP, or iASP for virtual tape

To determine the ASP in which you plan to store your virtual volume images, apply the following considerations:

► System ASP

Consider the following before you decide to store the virtual images in a System ASP:

- Amount of disk arms.
- Enough free space to store the volume images.
- Possible data loss in case of disk failure in the system ASP.

Virtual tape volumes will also be lost. If they are not yet duplicated to physical tape volumes, data will be lost.

- No additional disk configuration changes.

► User ASP

Consider the following before you decide to store the virtual images in a User ASP:

- Minimal impact on system performance when running backup or when duplicating virtual tape volumes to physical tape.
- Easy to set up.

- No data loss in case of disk failure in the system ASP and your virtual tape volumes are not duplicated yet. However, this requires additional tasks to be performed after you recover your system ASP. It also requires a disk configuration change if you do not have a user ASP.

► Standalone iASP

A standalone or private iASP is a separate ASP in which you can store your application data or other objects. Consider the following before you decide to use a standalone iASP for storing the virtual tape volumes:

- Minimal impact on system performance when running backup or when duplicating the virtual tape volumes to physical tape.
- One or more disks for creating a standalone iASP. You can either add new disks or remove disks from the system ASP if you have enough disks and disk arms in your system ASP.
- Disk configuration change is required if you do not have an iASP.
- No data loss in case of disk failure in the system ASP and the virtual tape volumes are not yet duplicated.
- No additional steps required to recover the iASP in case of data loss in the system ASP.

► Switchable iASP

A switchable iASP can be used in a cluster environment used by many different systems. In this case, you can store the virtual tape volumes in your switchable iASP. When you want to restore them on another system, switch the iASP to that system and restore the data to that system. For switchable iASP, the following aspects should be considered:

- You cannot use only one disk for setting up a switchable iASP, unless the disk is in a separate tower. In case of a switchable iASP, the entire tower has to be switched.
- Switchable iASP is flexible. Data can be backed up on a system and restored on other systems without moving the images.
- There is no data loss if there is disk failure in the system ASP and virtual tape volumes are not yet duplicated.
- It involves more than simply a disk configuration change; switchable iASP is more complex to set up than a standalone iASP or a user ASP. It can only be used in a cluster environment.

## 2.3.2 Preparing to use a user ASP or an iASP

While planning to set up a user ASP or an iASP, you should decide on the disks to allocate and how to allocate them.

### Preparing to add, remove, or move disks

While preparing to use a user ASP or iASP for your virtual tape volumes, consider one or more of the following options:

- ▶ Moving one or more disks from a system ASP to a user ASP  
You can use this option if you have enough disks arms and disk capacity.
- ▶ Removing one or more disks in order to reserve the disks for setting up an iASP

In this case, you have to ensure that you have enough disk space and disk arms. You may even consider a switchable or standalone iASP. A switchable iASP can be used by other systems in a cluster environment. A standalone iASP cannot be switched or attached to another system to access virtual volumes. However, in the case of a switchable iASP, the entire tower, with all the IOPs and disks, are switched, which means that you cannot set up a switchable iASP for one disk.

- ▶ Adding new disks for setting up an user ASP or an iASP  
You can use this option in one of the following cases:
  - You want to add new disks because you do not have enough disks or disk arms in your system ASP.
  - You just removed disks and want to add them now for setting up an iASP.
  - You want to add new disks for setting up an iASP.

### Adding, removing, or moving disks using the 5250 console

To add, remove, or move disks on a 5250 console, do the following:

1. In your operator panel, select the **Manual** mode.
2. In the console command line, type:  

```
PWRDWN SYS RESTART(*YES) IPLSRC(B)
```
3. Once the DST screen is shown on the console, do the following:
  - a. In the IPL or Install the System menu, select **3.Use Dedicated Service Tools (DST)** and sign in with the user ID QSEC0FR or any other user ID with sufficient authority.

- b. In the Use Dedicated Service Tools (DST) menu, select **4. Work with disk units**, → **1. Work with disk configuration**, → **3. Work with ASP configuration**.

In this screen, you will find the options to remove the disk units or move them to another ASP.

### **Adding, removing, or moving disks with iSeries Navigator**

For details about removing or moving disks using IBM @server iSeries Navigator, refer to the IBM @server iSeries Information Center. In the Contents frame on the left side, select **iSeries Information Center Version 5 Release 4**, expand **Systems management**, and select **Disk management** → **Configure the disks**.

This information can also be accessed on the Web at:

<http://publib.boulder.ibm.com/infocenter/iseriess/v5r4/index.jsp>

## **2.3.3 Using virtual tape volumes in user ASPs**

After you have added one or more disks to ASP2 or another user ASP, a user ASP is created. You should now prepare to create tape images in the user ASP. For storing the tape images in the user ASP, create a User Defined File System (UDFS).

To create a UDFS, follow these steps:

1. In the command line, type the following command, where XX is the ASP number:

```
CRTUDFS '/dev/qaspXX/aspXX.udfs'
```

2. To create a mount point directory, type the following command:

```
MKDIR '/your-path'
```

3. Mount the UDFS file system with this command:

```
MOUNT *UDFS '/dev/qaspXX/aspXX.udfs' '/mount-point-directory'
```

Anything you create from now in '/mountpoint' is created in the UDFS.

When you create the image catalog, specify the mount point for the directory name.

The following example shows how a UDFS works:

1. Assume that you have a directory '/imgclg/tape/NotMounted' created in the system ASP before you mounted the UDFS file system. Type WRKLNK '/imgclg/tape', type **5** in the Opt column, and press Enter. A window resembling Figure 2-4 on page 18 is shown.

```

Work with Object Links

Directory . . . . : /imgclg/tape

Type options, press Enter.
  2=Edit  3=Copy  4=Remove  5=Display  7=Rename  8=Display attributes
  11=Change current directory ...

Opt  Object link          Type  Attribute  Text
     NotMounted          DIR

Parameters or command
====>
F3=Exit  F4=Prompt  F5=Refresh  F9=Retrieve  F12=Cancel  F17=Position to
F22=Display entire field          F23=More options

Bottom

```

Figure 2-4 UDFS file system is not mounted

2. Mount the UDFS file system with the following command, and press F5:  
MOUNT TYPE(\*UDFS) MFS('/dev/qasp02/asp02.udfs') MNTOVRDIR('/imgclg/tape')
- A window resembling Figure 2-5 on page 19 appears.

```

Work with Object Links

Directory . . . . : /imgclg/tape

Type options, press Enter.
 2=Edit  3=Copy  4=Remove  5=Display  7=Rename  8=Display attributes
11=Change current directory ...

Opt  Object link          Type  Attribute  Text
MyCatalogDirectory >  DIR
MyCatalogDirectory >  DIR

                                                                 Bottom

Parameters or command
===>
F3=Exit  F4=Prompt  F5=Refresh  F9=Retrieve  F12=Cancel  F17=Position to
F22=Display entire field          F23=More options

```

Figure 2-5 UDFS file system mounted

Since you have now mounted the UDFS file system, you can use the directories in the user ASP.

**Note:** You cannot specify the mount-point directory when specifying a path name with the CRTIMGCLG command. Only the directory below the mount-point can be specified.

Mounts of UDFS file systems do not survive IPLs. Therefore, if you want to use your UDFS file system after an IPL, you should mount it again. You can also decide to add this to your startup program.

### 2.3.4 Using virtual tape in an iASP

Setting up a standalone iASP or switchable ASP is more complex than setting up a user ASP. The decision about whether to choose a switchable iASP or not depends on what you want to do with the virtual volumes.

If you have chosen a strategy in which you want to restore the volumes to more than one different system, opt to set up a switchable iASP.

For virtual tape you probably need only one tower for an iASP. However, to show the possibilities, a configuration with many switchable iASPs is shown in Figure 2-6.

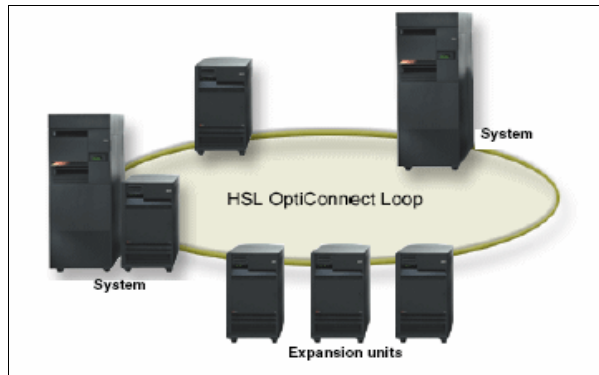

Figure 2-6 Switchable independent ASPs

For details about how to set up iASPs, refer to the IBM @server iSeries Information Center. In the Contents frame on the left, select **iSeries Information Center Version 5 Release 4**, expand **Systems management**, → **Disk management** → **Plan for disk management** → **Plan for independent disk pools**.

This can also be accessed on the Web at:

<http://publib.boulder.ibm.com/infocenter/iseriess/v5r4/index.jsp>

For more information and practical tips, refer to the IBM Redbook *IBM @server iSeries Independent ASPs: A Guide to Moving Applications to IASPs*, SG24-6802.

IBM Redbooks can be accessed on the Web at:

<http://www.redbooks.ibm.com>

To use a virtual tape volume in an independent ASP, specify the ASP device name as the first part of the IFS path name. The independent ASP must be varied on before the virtual tape volumes are usable.

**Note:** RSTLICPGM is not possible from virtual tape volumes that are stored in an iASP.

## 2.4 Performance considerations

Using virtual tape does not guarantee that your save window decreases.

The following items can affect the save/restore performance:

- ▶ Amount of disk arms.

In general, the more disk arms you have, the better the virtual tape save performance will be, especially for large file workloads.

- ▶ Available main storage in the system.

- ▶ Number of virtual tape drives.

Use of multiple virtual drives can result in better performance. However, at some point, the number of virtual tape drives start to give less value from a performance perspective.

- ▶ After the data is saved to virtual volumes, the data has to be moved to physical media by using the DUPTAP or DUPMEDBRM command, unless you plan to copy or FTP the image to another system.
- ▶ When creating the virtual tape volume images, you can specify a minimum size for the allocated storage size, for example, `ADDIMGCLGE . . . .ALCSTG(*MIN)`. This means that initially, the minimum size is 4 KB and when required, additional storage is allocated. However, this can significantly affect your save performance, making it up to 30% slower.

**Note:** Duplicating virtual volumes to physical media on systems with a small amount of disk arms will result in poor performance if the virtual volumes are stored in the system ASP. This is because the disk reads increase significantly, thereby affecting the overall system performance.

Appendix C, “Quick start guide” on page 471, contains virtual tape benchmark statistics of different configurations and types of data.

## 2.5 Requirements

Virtual tape implementation requires certain specifics with regard to operating system level, hardware, resources, and security.

### 2.5.1 Operating system requirements

Virtual tape on i5/OS requires the following operating system requirements:

#### **i5/OS V5R4 or above**

In order to determine which i5/OS version you have installed, use one of the following commands:

- ▶ Enter the following command and press F11:  
DSPSFWRSC
- ▶ Type GO LICPGM, press Enter, select **10. Display installed licensed programs**, then press **Enter** and **F11**.

If you do not have V5R4 installed and want to install i5/OS V5R4, follow the instructions provided in the IBM @server iSeries Information Center. In the Contents frame on the left side, select **iSeries Information Center Version 5 Release 4**, expand **i5OS and related software**, and select **Upgrading or replacing i5OS and related software**.

This can also be accessed on the Web at:

<http://publib.boulder.ibm.com/infocenter/iseriess/v5r4/index.jsp>

**Note:** V5R4 requires a load source with a minimum size of at least 17 GB.

#### **PTFs**

To determine the level of SF99186 you have installed, use the following command:

```
WRKPTFGRP
```

To determine the latest available level of SF99186, go to the following Web site and perform the actions detailed here:

<http://www-03.ibm.com/servers/eserver/support/iseriess/>

Click **Technical databases**, select **Preventive Service Planning** → **All Group PTFs by release**, and select **R540**.

## 2.5.2 Hardware requirements

For backup to virtual tape, you do not require a tape drive or tape library physically attached at backup time. However, the backup images on the system should be moved to the physical media or another system after the backup is completed. The hardware requirements listed here should be considered.

- ▶ Physical tape drive or tape library  
Do you have a physical tape drive or tape library with an available drive, including the required IOP or IOA to attach to the system in order to duplicate the virtual volumes to physical media?
- ▶ Available space in the system ASP  
Do you have sufficient space on the system for storing your virtual tape images?
- ▶ Possible space for user ASP or iASP  
Do you have enough space and disk arms on the system for moving or removing disk units in order to create a user ASP or iASP? If you do not expect to have enough disk space or disk arms, consider adding additional disks.

## 2.5.3 Resource requirements

Another requirement is resources, such as skills and test abilities.

### **Skill requirements**

Familiarize yourself with backup and recovery operations before starting with virtual tape. Although virtual tape is a good solution that fits with your backup strategy, it actually adds an additional step to your backup process.

The skill requirements listed here may hold true, depending on the backup strategy you use.

### ***Tape management***

You should be knowledgeable about tape management on i5/OS and be able to do the following:

- ▶ Manage and duplicate volumes.
- ▶ Manage and use a tape library or tape device.

### ***Backup and restore skills***

You should perform a check on your backup skills and ensure that you are familiar with the following:

- ▶ Backup and restoration of any object on i5/OS

- ▶ Database

There can be many situations in which database knowledge is required, for example, if a backup or restore fails due to pending record changes, pending constraints, file dependencies, and so on.

- ▶ Journaling

Sometimes it may be necessary to apply journal changes in order to bring the system backup into the original state.

### ***BRMS skills***

If you are using BRMS, you should be familiar with BRMS and possess the knowledge to perform a system recovery with BRMS. You should be able to interpret the recovery reports.

### **Ability to test**

We recommend that you perform a recovery test once you have set up the virtual tape for use in your backup strategy. In case of recovery disaster or data loss, you should be able to recover in order to bring your system back into the latest state. Following are the issues you should consider:

#### ***Ability to save and recover at the object level***

You should be able to save and recover the system at the object level, and consider if you have ever tested this.

#### ***Recover a system from tape***

Ask yourself if you have ever recovered a system from scratch using the backup or done a disaster recovery test. You should be able to do at least this before you start with virtual tape for your backup.

For more information about disaster recovery, refer to the IBM @server iSeries Information Center. In the Contents frame on the left side, select **iSeries Information Center Version 5 Release 4**, expand **Systems management**, and select **Backup and recovery** → **Plan a backup and recovery strategy, Plan a disaster recovery**.

This information can be accessed on the Web at:

<http://publib.boulder.ibm.com/infocenter/iseriess/v5r4/index.jsp>

### ***BRMS***

If you are using BRMS for your backup, you should be able to use BRMS and recover your system with BRMS.

## ***Object security***

You should ask yourself if you experienced any network problems or object security problems after conducting a disaster recovery test. If the answer is yes, were you able to find the root cause?

### **2.5.4 Security requirements**

The authority requirements listed here are related to the image catalog commands and virtual tape commands. A complete list of authority requirements for all save commands and image catalog and virtual tape commands can be found in Appendix B, “Sample command language” on page 461.

To administer or create image catalogs:

- ▶ \*USE authority to any command that you want to use
- ▶ \*EXECUTE authority to library QUSRSYS
- ▶ \*CHANGE authority to the image catalog
- ▶ Execute (\*X) authority to library QUSRSYS
- ▶ \*USE authority to the virtual device description

To use an existing catalog:

- ▶ \*USE authority to any desired commands
- ▶ \*EXECUTE authority to library QUSRSYS
- ▶ \*USE authority to the image catalog
- ▶ Execute (\*X) authority to library QUSRSYS
- ▶ \*USE authority to the virtual device description

To add an image file from physical media, \*USE authority to the physical device is required.

To add an image file from an existing image located in a different directory, the required authority is the same as for the CPY (Copy Object) command.

**Note:** The user profile used to create the virtual tape volumes has its maximum storage allowed attribute set to \*NOMAX. You can verify and change it with the following command:

```
WRKUSRPRF USRPRF(YourProfile)
```

## 2.6 Limitations

Most save and restore commands that can write to tape will also be allowed to use virtual tape. The limitations listed here apply for virtual tape.

### 2.6.1 Installing i5/OS and related software

With regard to installation of SLIC, i5/OS base software, and licensed programs, the following limitations apply:

- ▶ Installing SLIC or base operating system using virtual tape is currently not supported.

An IPL from virtual tape is not supported. Even if IPL from an optical image catalog is supported, an IPL from a tape catalog is not possible today.

Scratch install from a virtual tape volume is not possible, since there are no virtual tape volumes on the system at that time to IPL. If you have to install a system from scratch, use either a physical optical drive or physical tape device as the alternate IPL device.

- ▶ Restore of licensed programs (RSTLICPGM) is supported. However, only system ASP is currently supported for RSTLICPGM.

RSTLICPGM from virtual tape in iASP or user ASP is not supported.

### 2.6.2 Unsupported commands and functions

Although most save, restore, and related commands are supported for virtual tape, there are a few exceptions.

#### Commands

The following commands are not supported for virtual tape:

- ▶ VFYTAP
- ▶ SAVSTG

The command for creating an image catalog, **CRTIMGCLG**, supports only the following file systems:

- ▶ “root” (/)
- ▶ QOpensys
- ▶ UDFS having a \*TYPE2 default file format

## SST and DST functions

The following SST and DST functions are currently not supported:

- ▶ Dump to Media is not supported. This option presents a list of tape devices to choose from. The list does not include virtual tape devices.
- ▶ Copying Main Storage Dump (MSD ) to virtual tape is not supported. However, for MSD, there is already an option to copy the MSD to ASP.
- ▶ Lifetime statistics and session statistics in PAL™ under SST does not show virtual volumes. The only statistics available for virtual tape volumes are the current number of bytes information retrievable through the API QVOIRCLD.

### 2.6.3 Other limitations

Following are the remaining limitations:

- ▶ A maximum number of 35 virtual devices are supported.
- ▶ There is no support for virtual tape libraries. Only standalone virtual tape devices are supported. However, this should not be a problem since the virtual tape devices behave as a single drive tape library with a Random Access Automatic Cartridge Loader (RACL), and will automatically mount volumes.

## 2.7 Planning for Backup Recovery Media Services

Virtual tape can also be used within Backup Recovery Media Services (BRMS). This section discusses only the BRMS planning steps. Chapter 4, “Multiple virtual tape scenarios” on page 141 discusses using BRMS with virtual tape in detail.

If you are not using BRMS and are not familiar with using BRMS, follow the instructions provided in the IBM @server iSeries Information Center. In the Contents frame on the left side, select **iSeries Information Center Version 5 Release 4**, expand **Systems management**, and select **Backup and recovery** → **Backup, Recovery and Media Services**.

This information can be accessed on the Web at:

<http://publib.boulder.ibm.com/infocenter/iseriess/v5r4/index.jsp>

## Installing BRMS

If you do not know whether BRMS is installed on your system, perform the following tasks:

1. Enter the following command:

```
GO LICPGM
```

2. Select **10. Display installed licensed programs**, press F11 twice, and press PgDn until you see the required products:

- 5722SS1 18      Media and Storage Extensions
- 5722BR1 \*BASE Backup Recovery and Media Services

You may also have the following BRMS Licensed Programs. However, they are optional and not required for virtual tape:

- 5722BR1 1      BRMS-Network feature
- 5722BR1 2      BRMS-Advanced Functions Feature

### ***Installing BRMS if not installed already***

If you do not have both the products, install it. In our scenario, only the BRMS \*BASE option is used. However, you can also install the other BRMS options.

To install the licensed programs, refer to the IBM @server iSeries Information Center. In the Contents frame on the left side, select **iSeries Information Center Version 5 Release 4**, expand **i5/OS and related software**, and select **Install, upgrade, or delete i5/OS and related software** → **Installing i5/OS and related software on a new server or logical partitioning** → **Installing additional licensed programs**. Click **Work with Licensed Programs menu to install IBM licensed programs**.

This can be accessed on the Web at:

<http://publib.boulder.ibm.com/infocenter/iseriess/v5r4/index.jsp>

### ***PTFs***

We recommend that you apply the most recent backup and recovery group PTFs as a requirement for virtual tape. However, the backup and recovery group PTF also contains fixes for licensed programs Media Storage Extensions and BRMS. To check the group PTF level, follow the instructions in “PTFs” on page 22.

### **Considerations for BRMS with virtual tape**

BRMS handles virtual tape devices and virtual tape volumes as physical tape devices and physical tape volumes. However, keep the following in mind:

- ▶ Only one volume can be added at a time using ADDMEDBRM. If you want to add a large amount of volumes, write a small CL program that adds all the volumes one by one.

- ▶ Use of catalog shadowing is not possible within BRMS. This means that you cannot restore objects from multiple devices using the same volume at the same time.
- ▶ As described in 2.6.3, “Other limitations” on page 27, virtual tape libraries are not supported. This implies that for parallel saves and concurrent saves within BRMS, separate drives must be specified.
- ▶ Virtual volumes cannot be shared using the BRMS network feature. When adding a media class within BRMS and specifying a virtual volume density (\*VRTxxxK), the Shared Media parameter must be set to \*N0. However, there is no need to share these volumes with other systems, since the other systems within the BRMS network are not able to use them.
- ▶ BRMS requires unique volume names. Although you can have the same volume names in different image catalogs, you can use only one of them.

In a BRMS network, you have to ensure that the volume name you want to add to BRMS does not exist on any other system in the network.

One of the benefits of virtual tape within BRMS is that you do not have your physical drives available for the actual backup, regardless of whether you use single, concurrent, or parallel backups. However, for parallel backups, you must ensure that the amount of physical drives matches the amount of used virtual drives for the backup.

## Virtual tape versus savefiles in BRMS

Releases prior to V5R4 BRMS had the ability to use savefiles for temporarily saving the data to DASD. The performance is almost the same for BRMS savefiles and virtual tape. However, virtual tape is more flexible than savefiles. Table 2-1 shows the differences and possibilities.

Table 2-1 Differences between BRMS savefiles and virtual tape

	BRMS savefiles	Virtual tape
Append data to existing volumes	Yes	Yes
Migrate data to physical media	SAVSAVFBRM	DUPTAP DUPMEDBRM
Can be created in user ASP	Yes	Yes
Can be created in independent ASP	No	Yes
*SAVSYS SAVSYSBRM	No	Yes

	<b>BRMS savefiles</b>	<b>Virtual tape</b>
Parallel backup	No	Yes
Maximum size limit per savefile or single virtual volume	approx 1 TB	1 TB
Maximum size of multiple virtual tape volumes		256 TB
Save While Active *SYNCLIB	No	Yes

## Checklist

Use the checklist shown in Table 2-2 when planning for virtual tape.

*Table 2-2 Checklist for planning for virtual tape*

<b>Task number</b>	<b>Description</b>	<b>Where to find more information</b>
___Task 1	Hardware: <ul style="list-style-type: none"> <li>▶ Determine the space you have now and determine the required space for virtual tape.</li> </ul>	<ul style="list-style-type: none"> <li>▶ 2.2.2, “The amount of space needed” on page 11</li> <li>▶ 2.3.2, “Preparing to use a user ASP or an iASP” on page 16</li> </ul>
___Task 2	<ul style="list-style-type: none"> <li>▶ Move, remove, and add disks.</li> </ul>	
___Task 3	Software: <ul style="list-style-type: none"> <li>▶ Check if V5R4 is installed and install it if it is not.</li> </ul>	<ul style="list-style-type: none"> <li>▶ 2.5.1, “Operating system requirements” on page 22</li> <li>▶ 2.7, “Planning for Backup Recovery Media Services” on page 27</li> <li>▶ “PTFs” on page 22</li> </ul>
___Task 4	<ul style="list-style-type: none"> <li>▶ If you want to use BRMS, check if BRMS is installed and install it if it is not.</li> </ul>	
___Task 5	<ul style="list-style-type: none"> <li>▶ Check PTF level and apply new PTFs, if necessary.</li> </ul>	

Task number	Description	Where to find more information
<p>___Task 6</p> <p>___Task 7</p> <p>___Task 8</p> <p>___Task 9</p>	<p>User ASP:</p> <ul style="list-style-type: none"> <li>▶ Set your user ASP.</li> </ul> <p>Mount your UDFS in the user ASP.</p> <p>Standalone iASP:</p> <ul style="list-style-type: none"> <li>▶ Set up your standalone iASP.</li> </ul> <p>Switchable iASP:</p> <ul style="list-style-type: none"> <li>▶ Set up your switchable iASP.</li> </ul>	<ul style="list-style-type: none"> <li>▶ 2.3.3, “Using virtual tape volumes in user ASPs” on page 17</li> <li>▶ 2.3.3, “Using virtual tape volumes in user ASPs” on page 17</li> <li>▶ 2.3.4, “Using virtual tape in an iASP” on page 19</li> <li>▶ 2.3.4, “Using virtual tape in an iASP” on page 19</li> </ul>
<p>___Task 10</p> <p>___Task 11</p> <p>___Task 12</p> <p>___Task 13</p> <p>___Task 14</p> <p>___Task15</p>	<p>Operational procedures:</p> <ul style="list-style-type: none"> <li>▶ Change your backup hierarchy to include virtual tape.</li> <li>▶ How much data is saved.</li> <li>▶ How many saves you want to keep.</li> <li>▶ Create documentation for duplicating virtual tape volumes.</li> <li>▶ Change or create documentation for restoring objects from virtual tape.</li> <li>▶ Test your backup plan by doing a disaster recovery test.</li> </ul>	<ul style="list-style-type: none"> <li>▶ 2.3.2, “Preparing to use a user ASP or an iASP” on page 16</li> <li>▶ 2.2, “Considering the backup strategy” on page 10</li> <li>▶ 2.2, “Considering the backup strategy” on page 10</li> <li>▶</li> <li>▶</li> <li>▶ “Ability to test” on page 24</li> </ul>





## Implementing virtual tape storage

In this chapter we describe the commands you need to create and utilize virtual tape storage. We also discuss the steps for creating a tape image catalog and virtual tape media, and how to utilize them to perform a save/restore function.

We also explain here the concept of catalog shadowing, and detail the steps involved in creating dependent image catalogs.

## 3.1 Setting up virtual tape storage

This section provides a high-level overview of the steps used to set up virtual tape storage. The overview explains how to set up virtual tape storage for the most common tasks. The exact steps you use to set up virtual tape storage may vary depending on the specific task you want to accomplish.

Information pertaining to most of these actions can be found in IBM @server iSeries Navigator by selecting **Configuration and Service** → **Hardware** → **Tape Devices**, and then clicking or right-clicking **Tape Image Catalogs**. If using a 5250 emulation session, most image catalog commands can be found within the **GO IMGCLG** menu.

The tasks involved in creating a tape image catalog, as illustrated in Figure 3-1, are as follows:

- ▶ Create a virtual tape device
- ▶ Vary on the tape device
- ▶ Create the tape image dialog
- ▶ Add virtual tape image to the tape image catalog
- ▶ Load the image catalog in the virtual device

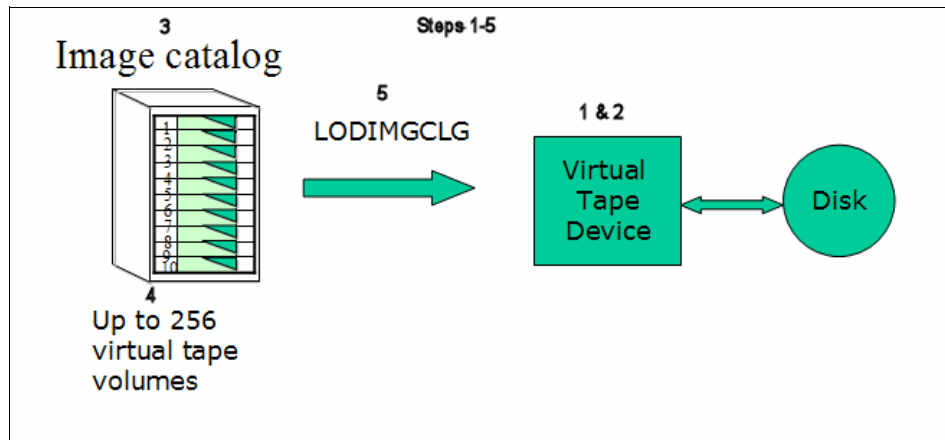

Figure 3-1 Tape image catalog diagram

We explain these tasks in more detail here:

### Create a virtual tape device

If you do not have a virtual tape device (type 63B0), then create one. Check your devices through IBM @server iSeries Navigator by selecting **Configuration and Service** → **Hardware** → **Tape Devices** → **Stand-Alone Devices**. Your devices

will show up in the right window pane, with the virtual devices having a Type Model of 63B0 as shown in Figure 3-2.

Tape Device	Status	Type-Model	Description	Image Catalog	Mounted Volume
Japvrttap1	Available	63B0-001		JAPCATALOG	VRT001
Jjpvrttap	Available	63B0-001		JJPTAP	
Lantap	Available	63B0-001			
Tapvrt01	Available	63B0-001	TAPVRT01 Virtual Tape device	VTAPTEAM01	VOL01B
Tapvrt02	Unavailable	63B0-001	Virtual tape device TAPVRT02		
Tapvrt03	Unavailable	63B0-001	Virtual tape device TAPVRT03		
Tapvrt04	Available	63B0-001	Virtual Tape Device		
Tap01	Unavailable	6382-001	CREATED BY AUTO-CONFI...		
Tap03	Unavailable	3570-C12	CREATED BY AUTO-CONFI...		
Tap04	Unavailable	3570-C12	CREATED BY AUTO-CONFI...		
Tap05	Available	63B0-001	Virtual Tape device	DUPLICATE	DUP001

Figure 3-2 Checking standalone tape devices through Navigator

To view your tape devices from a 5250 emulation session, enter the following command:

```
WRKDEVD DEVD(*TAP)
```

To the right of the device description name, there is a field called Type. If your device description is Type 63B0, it means that it is a virtual device and you can proceed to the next step.

Figure 3-3 on page 36 shows the WRKDEVD DEV(\*TAP) screen. As you can see, TAPVRT01 is Type 63B0, indicating that it is a virtual tape device.

```

Work with Device Descriptions
System: RCHITSO
Position to . . . . . _____ Starting characters

Type options, press Enter.
  2=Change  3=Copy  4=Delete  5=Display  6=Print  7=Rename
  8=Work with status  9=Retrieve source

Opt Device      Type      Text
-  TAPVRT01     63B0     TAPVRT01 Virtual Tape device
-  TAP01        6382     CREATED BY AUTO-CONFIGURATION
-  TAP03        3570     CREATED BY AUTO-CONFIGURATION
-  TAP04        3570     CREATED BY AUTO-CONFIGURATION

Bottom

Parameters or command
===>
F3=Exit  F4=Prompt  F5=Refresh  F6=Create  F9=Retrieve  F12=Cancel
F14=Work with status

```

Figure 3-3 Working with tape devices through 5250 emulation

**Note:** If you view the virtual tape device from another system, it will show that it is configured as 3580-002.

Perform the following tasks to create a virtual device:

Currently, you cannot create a virtual device through IBM @server iSeries Navigator directly. However, from IBM @server iSeries Navigator, you can change an existing device description to be a virtual device, as shown in Figure 3-4 on page 37.

1. Select **Configuration and Service** → **Hardware** → **Tape Devices** → **Stand-Alone Devices**, right-click your device description and select **Properties**.
2. For Hardware resource, scroll the down arrow and select **Generate virtual resource**.
3. Click the Options tab and ensure that **Make available when system restarts** is checked, then click **OK**.

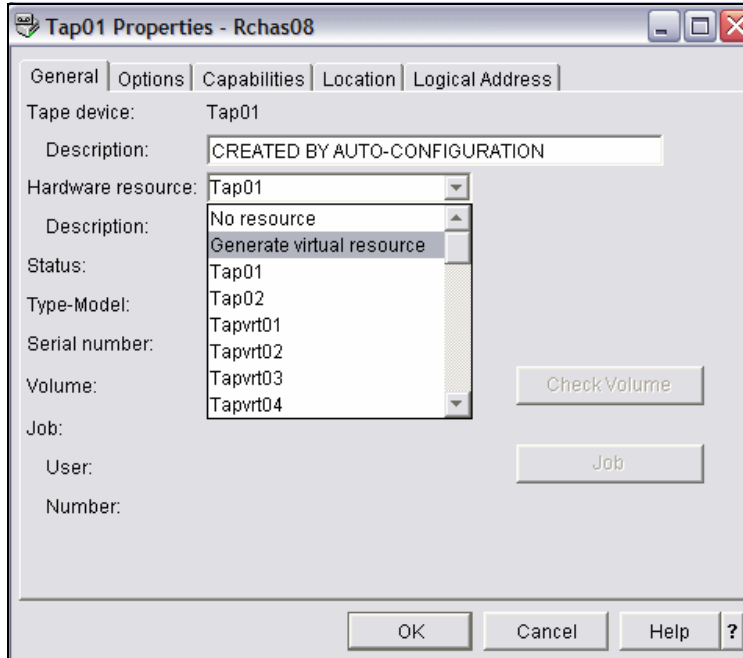

Figure 3-4 Changing existing device to virtual device

If using a 5250 emulation session, you can prompt on the Create Device Description (Tape) (CRTDEVTAP) command and enter the values for the parameters.

The DEVD parameter is the name of your device; RSRCTYPE should be \*VRT for virtual; and ONLINE should be set to \*YES. To create your virtual device, enter the following command:

```
CRTDEVTAP DEVD(TAPVRT01) RSRCTYPE(*VRT) ONLINE(*YES)
```

The CRTDEVTAP parameters are shown in Figure 3-5 on page 38.

```

Create Device Desc (Tape) (CRTDEVTAP)

Type choices, press Enter.

Device description . . . . . > TAPVRT01      Name
Device type . . . . . *RSRCNAME      *RSRCNAME, 2440, 3422, 3430..
Device model . . . . . *RSRCNAME      *RSRCNAME, 1, 2, 12, A01...
Resource name . . . . . > *VRT        Name, *NONE, *VRT...
Online at IPL . . . . . *YES          *YES, *NO
Attached controller . . . . .          Name
Assign device at vary on . . . . *YES      *YES, *NO
Unload device at vary off . . . *NO        *YES, *NO
Message queue . . . . . *SYSOPR      Name, *SYSOPR
Library . . . . .          Name, *LIBL, *CURLIB
Text 'description' . . . . . Virtual tape Device TAPVRT01

Bottom

F3=Exit  F4=Prompt  F5=Refresh  F10=Additional parameters  F12=Cancel
F13=How to use this display  F24=More keys

```

Figure 3-5 Create virtual device through 5250 emulation

### Vary on the tape device

Vary on your virtual tape device by selecting **Configuration and Service** → **Hardware** → **Tape Devices** → **Stand-Alone Devices**, right-clicking your device description, and selecting **Make Available**; see Figure 3-6.

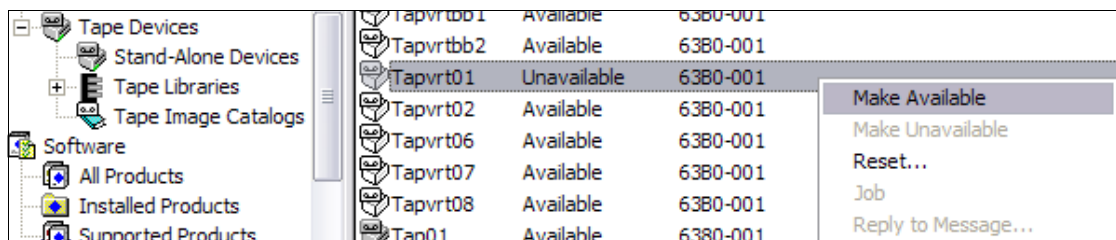

Figure 3-6 Varying on virtual tape device through Navigator

**Important:** Do *not* issue a Reset on a virtual device.

If using a 5250 emulation session, you can vary on your virtual tape device by issuing the Vary Configuration (VRYCFG) command:

```
VRYCFG CFGOBJ(TAPVRT01) CFGTYPE(*DEV) STATUS(*ON)
```

**Note:** You can have up to 35 virtual tape devices varied on at one time.

**Important:** Avoid using the VRYCFG command with STATUS(\*RESET) for a virtual device.

If you have already created a virtual device, but do not remember its name, issue the following command and press Enter:

```
WRKDEVD DEVD(*TAP)
```

This brings up a list of all your tape devices. Figure 3-7 shows TAPVRT01 as TYPE 63B0.

```
Work with Device Descriptions
System: RCHITSO
Position to . . . . . Starting characters
Type options, press Enter.
  2=Change  3=Copy  4=Delete  5=Display  6=Print  7=Rename
  8=Work with status  9=Retrieve source

Opt Device      Type      Text
--- TAPVRT01    63B0     Virtual Tape device 01
--- TAPVRT07    63B0     Virtual Tape device 07
--- TAPVRT08    63B0     Virtual Tape device 08
--- TAP01      6380     CREATED BY AUTO-CONFIGURATION
--- TAP02      6382     CREATED BY AUTO-CONFIGURATION

Parameters or command
====>
F3=Exit  F4=Prompt  F5=Refresh  F6=Create  F9=Retrieve  F12=Cancel
F14=Work with status

Bottom
```

Figure 3-7 Working with tape devices through 5250 emulation

In the Work with Device Descriptions window, select option **8=Work with Status**, and then select option **1=Vary On**.

If your Assistance level is Basic, the option will be **Make Available**, which is the same as Vary on. To change your assistance level, press F21 or Shift+F9 and choose **2=Intermediate** or **3=Advanced**).

Figure 3-8 shows the Work with Status window and the selection of option 1 to vary on the tape device.

```

                                Work with Configuration Status                                RCHAS08
                                                                                          12/02/05 17:58:09
Position to . . . . .                Starting characters

Type options, press Enter.
  1=Vary on   2=Vary off   5=Work with job   8=Work with description
  9=Display mode status   13=Work with APPN status...

Opt Description      Status          -----Job-----
 1  TAPVRT01         VARIED OFF

Parameters or command
====>
F3=Exit  F4=Prompt  F12=Cancel  F23=More options  F24=More keys
  
```

Figure 3-8 Work with configuration status through 5250 emulation

After you select option 1 to vary on and press Enter, the tape device should have a status of VARIED ON or AVAILABLE.

### Create the tape image catalog

From IBM @server iSeries Navigator, create an image catalog by selecting **Configuration and Service** → **Hardware** → **Tape Devices**, right-clicking **Tape Image Catalogs**, and selecting **Create Image Catalog**, as shown in Figure 3-9 on page 41.

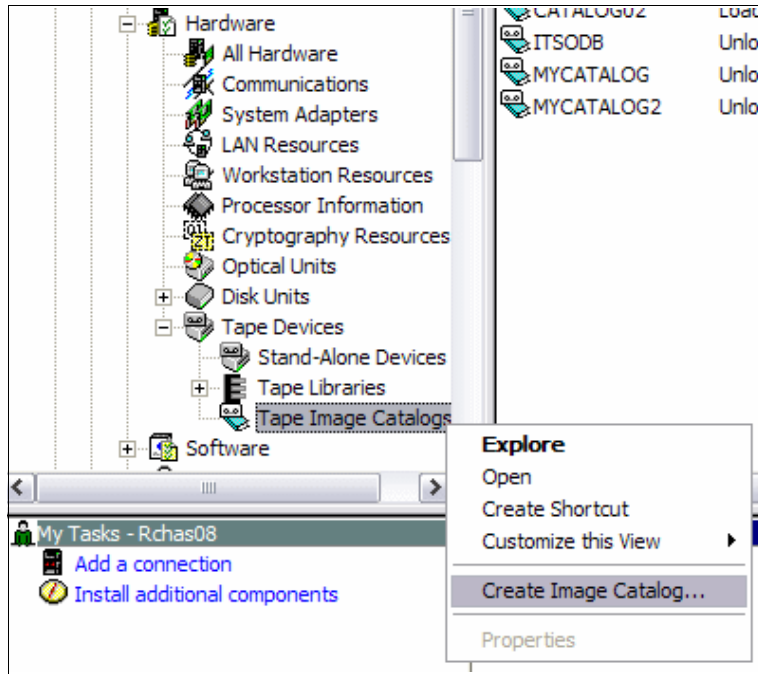

Figure 3-9 Creating image catalog through Navigator

You will see a window where you should choose your Catalog name (opt for a name that helps describes the volumes inside the image catalog, such as Nightly).

Then type in a short Catalog description (use a description to better describe what this catalog is used for, such as Nightly backup of Databases), and select a Directory path in the IFS where you want your image catalog to store its images.

Select **Create directory** if the directory does not exist already, and select an appropriate **Authority level**.

*Authority level* specifies the authority you are giving users who do not have specific authority for the object, who are not on an authorization list, and whose group profile or supplemental group profiles do not have specific authority for the object.

Following are the choices for Authority Level:

- ▶ Exclude: This is the default Authority Level. The user cannot access the image catalog unless the user:
  - Has \*ALLOBJ special authority
  - Is the owner of the object
  - Is granted authority later
- ▶ Library create: The authority for the object is the same as the create authority for QUSRSYS. The create authority for QUSRSYS can be displayed by using the Display Library Description (DSPLIBD) command.

If the create authority for QUSRSYS is set to \*SYSVAL, then display the QCRTAUT system value. If the create authority is changed with the Change Library (CHGLIB) command, the new authority does not affect existing objects.

- ▶ Change: The user can perform all operations on the object except those limited to the owner or controlled by object existence authority and object management authority. The user can change and perform basic functions on the object. Change authority provides object operational authority and all data authority. If the object is an authorization list, the user cannot add, change, or remove user IDs.
- ▶ All: The user can perform all operations except those limited to the owner or controlled by authorization list management authority. The user can control the object's existence, specify the security for the object, change the object, and perform basic functions on the object. The user also can change ownership of the image catalog.
- ▶ Use: The user can perform basic operations on the image catalog, such as displaying properties. However, the user cannot change the image catalog, and Use authority provides object operational authority, read authority, and execute authority.
- ▶ Name: Specify the name of an authorization list to be used for granting authority to the object. Users included in the authorization list are granted authority to the object, as specified in the list. The authorization list must exist when the object is created.

In the example provided here, \*EXCLUDE was selected for Authority Level. This means that no user can access the object or see the image catalog, if working with image catalogs, unless they have specific authority to the image catalog or \*ALLOBJ special authority.

Figure 3-10 shows the creation of an image catalog through IBM @server iSeries Navigator.

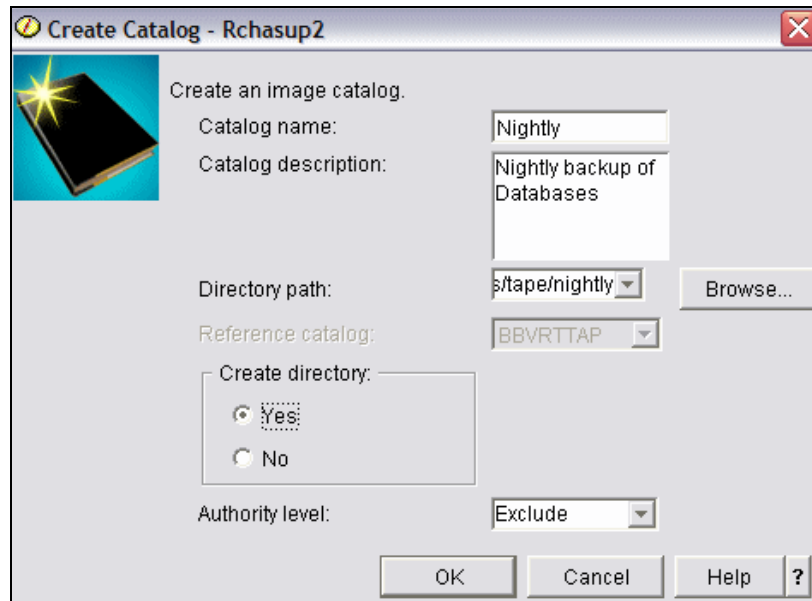

Figure 3-10 Parameters for creating image catalog in Navigator

**Note:** The directory or subdirectories do not have to exist prior to selecting Create directory. V5R4M0 and above have the capability to create the entire directory path.

To create a tape image catalog from a 5250 emulation session, enter the following command:

```
CRTIMGCLG IMGCLG(NIGHTLY) DIR('/images/tape/nightly') TYPE(*TAP) TEXT('Nightly backup of Databases')
```

In this command, NIGHTLY is the name of the image catalog, /images/tape/nightly is the IFS directory for the image catalog to place its images, 'Nightly backup of Databases' is a short description of the image catalog. You can also change the Authority Level (AUT) default value of \*EXCLUDE.

Figure 3-11 on page 44 shows the CRTIMGCLG command and its parameters.

```

Create Image Catalog (CRTIMGCLG)

Type choices, press Enter.

Image catalog . . . . . > NIGHTLY      Name
Directory . . . . . > '/images/tape/nightly'

Image catalog type . . . . . > *TAP      *OPT, *TAP
Create directory . . . . . *YES        *YES, *NO

Additional Parameters

Text 'description' . . . . . > 'Nightly backup of Databases'

Bottom
F3=Exit  F4=Prompt  F5=Refresh  F10=Additional parameters  F12=Cancel
F13=How to use this display  F24=More keys

```

Figure 3-11 Create image catalog through 5250 emulation

## Add the virtual tape image to the tape image catalog

Add the virtual tape volume by performing the following tasks:

- ▶ Create a new virtual tape volume
- ▶ Add an existing virtual tape file

### Create a new virtual tape volume

Figure 3-12 on page 45 and Figure 3-13 on page 47 show the creation of a new volume in IBM @server iSeries Navigator.

To create a new virtual tape volume through IBM @server iSeries Navigator, **select Configuration and Service → Hardware → Tape Devices**, right-click **Tape Image Catalogs**, then right-click the image catalog and select **Add Volume**. The window that appears will have two tabs: General and Optional.

The General tab is shown in Figure 3-12 on page 45.

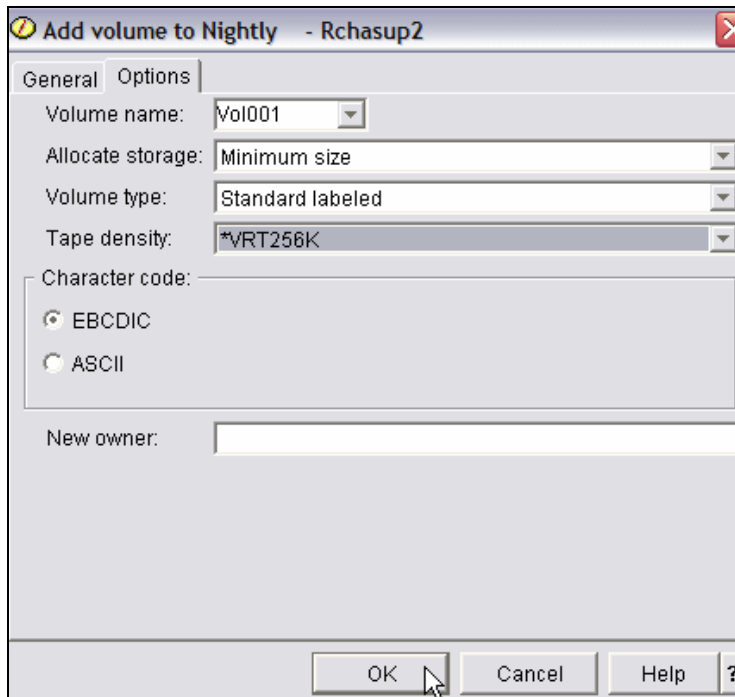

Figure 3-12 Adding new volume options through Navigator

The General tab contains the following parameters:

- ▶ The From tape image file (FROMFILE) should have New Image selected. This tells the system to create a new virtual tape file and add it to the image catalog. The image file will be created in the same directory path as the image catalog.
- ▶ The To tape image file (TOFILE) option allows you to specify a unique name for the tape image file that will be created in the Image Catalog's directory. (This is not to be mistaken with a volume name.)
- ▶ You can also specify a Volume Index (IMGVOLIDX), which is similar to the slot position in a physical tape cartridge loader. The Volume Index is the position where the virtual volume is positioned in the image catalog. Image catalogs have a maximum of 256 indexes per image catalog.

The Volume Index parameter has a default of First Available, which automatically assigns the lowest index number that is not already being used.

- ▶ Replace volume if index already exists (REPLACE) specifies the action to take if a volume with the same index number as that specified in the Volume

Index field already exists in the tape image catalog. The default value for Volume Index is No.

The values are described here:

- Yes: This specifies that the existing image volume will be replaced.
- No: This specifies that the existing volume will not be replaced and an error message will be issued.
- Insert: This specifies that the volume will be added or inserted if an existing index number already exists. If the image volume is inserted, the remaining volumes will be incremented by one up to the next available index number.
- ▶ Volume size in MB (IMGSIZ) specifies the size of the new image file that is to be created. For tape type image catalogs, this parameter indicates the maximum size allowed for this tape image file.

If Allocate Storage ALCSTG(\*MIN) is specified, only the amount of storage required to initialize the image file will be allocated (4 k) until the volume is auto-initialized the first time it is mounted. As data is written to the volume, additional storage is allocated as needed until the specified maximum volume size is reached.

If Allocate Storage ALCSTG(\*IMGSIZ) is specified, the amount of storage allocated will be the value specified on the Volume size (IMGSIZ) parameter.

The Options tab is shown in Figure 3-13 on page 47.

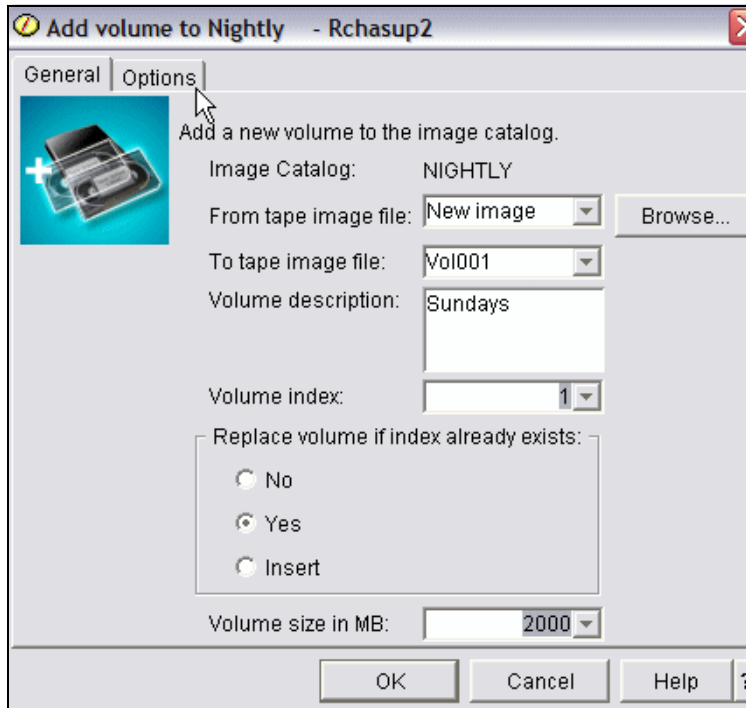

Figure 3-13 Adding new volume through Navigator

The Options tab has the following parameters:

- ▶ Volume name (VOLNAM): This specifies the volume name for this virtual tape volume. You can enter your own volume name or use the special value of \*GEN, which means the volume name will be generated by the system.
- ▶ Allocate storage (ALCSTG) specifies whether to allocate the entire amount of storage specified on the Image size (IMGSIZ) parameter, for the tape image files. This parameter is only allowed for Tape Type image catalogs (it is not allowed for Reference or Dependent Image catalogs).
  - \*MIN: This specifies changing the storage allocation to match the storage required to contain the existing image file data. If performing a save, the image file size is increased dynamically.

However, the image file size will no longer increase once the system reaches 5% or 5 GB storage remaining, whichever is less. This value is not valid for dependent catalogs or catalog shadowing.

- IMGSIZ: This specifies changing the storage allocation to match the entire size of storage for a given image file. This is the value specified on the image size (IMGSIZ) parameter of the ADDIMGCLGE command.

**Note:** For a better understanding of the Allocate Storage (ALCSTG) parameter refer to 3.2, “Using a tape image catalog” on page 58.

- ▶ Volume type (VOLTYP): This specifies the type of volume for this virtual tape volume.
  - \*SL: This specifies the that type of volume is a standard labeled tape volume.
  - \*NL: This specifies that the type of volume is a non-labeled tape volume.
- ▶ Tape density (DENSITY): This specifies the density for this virtual tape volume.
  - \*VRT256K: The format of the volume is \*VRT256K. It is used to write data to a virtual volume using a maximum data block size of 256 KB. Volumes written using this format can only be duplicated to tape devices that support a maximum block size of 256 KB or greater.
  - \*VRT240K: The format of the volume is \*VRT240K. It is used to write data to a virtual volume using a maximum data block size of 240 KB. Volumes written using this format can only be duplicated to tape devices that support a maximum block size of 240 KB or greater.
  - \*VRT64K: The format of the volume is \*VRT64K. It is used to write data to a virtual volume using a maximum data block size of 64 KB. Volumes written using this format can only be duplicated to tape devices that support a maximum block size of 64 KB or greater.
  - \*VRT32K: The format of the volume is \*VRT32K. It is used to write data to a virtual volume using a maximum data block size of 32 KB. Volumes written using this format can be duplicated to all supported tape devices.

**Note:** The DENSITY parameter should correspond to the block size of the physical tape drive’s capability, where you will eventually copy the virtual volumes to physical tapes.

- ▶ Character code (CODE): This specifies the character code in which the volume label is written. All data that is not save data written after the label must be in the same code. Codes cannot be intermixed on a tape that is not a save tape. This parameter is only used for a volume type of \*SL.
  - \*EBCDIC: The volume label is written in EBCDIC and is an IBM standard label. All additional data must also be written in EBCDIC.
  - \*ASCII: The volume label is written in ASCII and is an ANSI standard label. All additional data must also be written in ASCII.

- ▶ **New owner (NEWOWNID):** This specifies the identifier of the tape owner for this virtual tape volume. This parameter is only used for a volume type of \*SL.
  - \*BLANK: No identifier will be specified.
  - name: Specify no more than 14 characters that identify the owner of the virtual tape volume. If fewer than 14 characters are specified, the field is left-justified and padded on the right with blanks.

**Note:** New volumes do not have to be initialized since they are automatically created with a compatible format to the DENSITY that was specified during the volume's creation.

You can add enough volumes to your image catalog, as needed, for your backup. However, if your backup runs out of available volumes, additional volumes can be created on the fly. For more information refer to 3.2.2, "Automatic creation of new volumes" on page 65.

To add a new volume through a 5250 emulation session, enter the following command:

```
ADDIMGCLGE IMGCLG(Nightly) FROMFILE(*NEW) TOFILE(vo1001) VOLNAME(VOL1001)
TEXT('Sunday nightly backups Vo1001') VOLNAM(VOL001) DENSITY(*VRT256K)
```

Figure 3-14 on page 50 shows the 5250 emulation screen for adding an image catalog entry.

**Note:** New volumes do not have to be initialized, since they are automatically created with a compatible format to the DENSITY that was specified during the volume's creation.

```

                                Add Image Catalog Entry (ADDIMGCLGE)

Type choices, press Enter.

Image catalog . . . . . > NIGHTLY      Name
From optical device, or . . . . .      Name
From image file . . . . . > *NEW

To image file . . . . . > Vol001

Image catalog index . . . . . *AVAIL    1-256, *AVAIL
Replace catalog entry . . . . . *NO     *NO, *YES, *INSERT
Image size . . . . . > 2000           Megabytes, *CD650, *DVD2600...
Text 'description' . . . . . > Sunday nightly backups Vol001

                                Additional Parameters

Allocate storage size . . . . . *MIN     *MIN, *IMGSIZ
Tape volume name . . . . . > VOL001    Character value, *GEN
Type choices, press Enter.

Volume type . . . . . *SL              *SL, *NL
Tape density . . . . . *VRT256K       *VRT256K, *VRT240K...
New owner identifier . . . . . *BLANK  *BLANK
Code . . . . . *EBCDIC                *EBCDIC, *ASCII

                                                                Bottom
F3=Exit  F4=Prompt  F5=Refresh  F12=Cancel  F13=How to use this display
F24=More keys

```

Figure 3-14 Adding new volume through 5250 emulation

**Important:** The DENSITY parameter should correspond to the block size of the physical tape drive's capability, where you will eventually copy the virtual volumes to physical tapes.

### ***Adding an existing virtual tape file***

To add an existing virtual tape file through IBM @server iSeries Navigator, **select Configuration and Service → Hardware → Tape Devices**, right-click **Tape Image Catalogs**, right-click the image catalog, and select **Add Volume**. Click **Browse**, navigate the IFS directory path to the location of the tape images, select the virtual tape volume, and click **OK**. A window similar to the one shown in Figure 3-15 on page 52 will be displayed.

The General tab has the following parameters:

- ▶ The From tape image file option shows the directory path of the tape image file, once the existing volume is selected to be added.
- ▶ The To tape image file option allows for a special value of From File, which uses the same name as the source image. Otherwise, you can specify a different name in the To tape image file.
- ▶ You can also specify a Volume Index, which is similar to the slot position in a physical cartridge loader. The Volume Index is the order where the virtual volume is positioned in the image catalog. Image Catalogs can currently have a maximum of 256 indexes per image catalog. The Volume Index parameter has a default of First Available, which automatically assigns the lowest index number that is not already being used.
- ▶ Replace volume if index already exists specifies the action to take if a volume with the same index number as specified in the Volume Index field already exists in the tape image catalog. The default value is No. The values are described below:
  - Yes: This specifies that the existing image volume will be replaced.
  - No: This specifies that the existing volume will not be replaced and an error message will be issued.
  - Insert: This specifies that the volume will be added or inserted if an existing index number already exists. If the image volume is inserted, the remaining volumes will be incremented by one up to the next available index number.
- ▶ Volume size in MB is not a valid parameter when adding an existing volume into the image catalog. This parameter is only for creating new volumes. If a value is specified when adding an existing volume, the value is ignored and the added volume retains its original size.

The Options tab is also not valid when adding an existing volume. This tab contains parameters that can be used when adding a new volume.

Figure 3-15 on page 52 illustrates the addition of an existing volume, where the tape file image is in the same directory as the image catalog directory (/images/tape/nightly). Select the image catalog and right-click to show the options, then click option **Add Volume**.

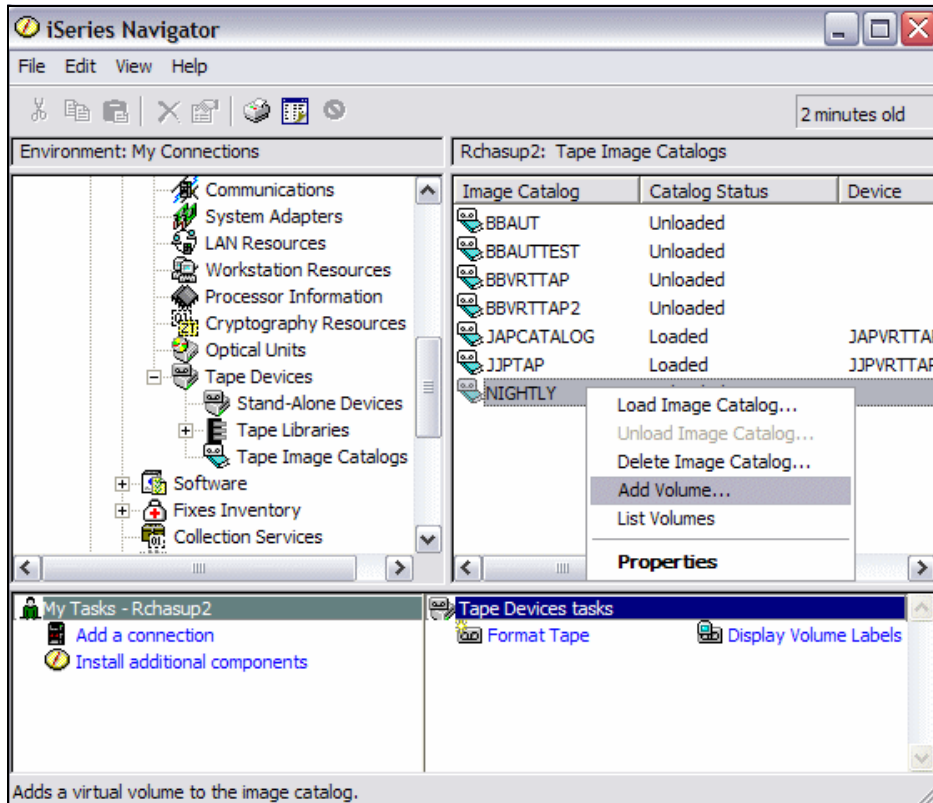

Figure 3-15 Adding volume through Navigator

In this case, only the image file is specified in the From File (FROMFILE) parameter. The To file (TOFILE) parameter is given a special value of \*FROMFILE.

If the existing tape image file is located in a different directory from the Directory path (DIR) of this image catalog (that is, the directory path when the image catalog was created), then the From file (FROMFILE) should have the full directory path, including the image file name, and the To file (TOFILE) could either have a value of \*FROMFILE or be given another file name (that is, the image file's STMF name and not the volume name).

Figure 3-16 on page 53, shows the FROMFILE and TOFILE selections.

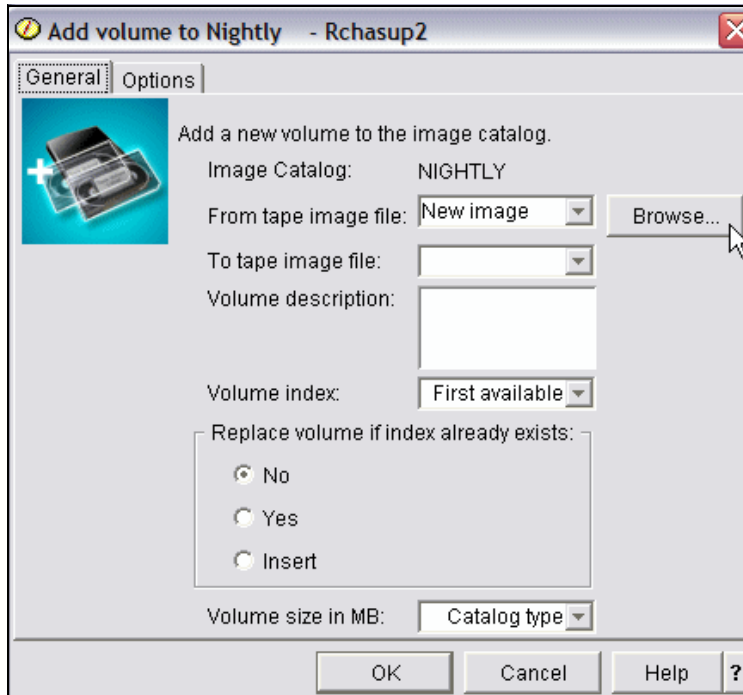

Figure 3-16 Browsing existing volumes

Clicking **Browse** displays files, as shown in Figure 3-17.

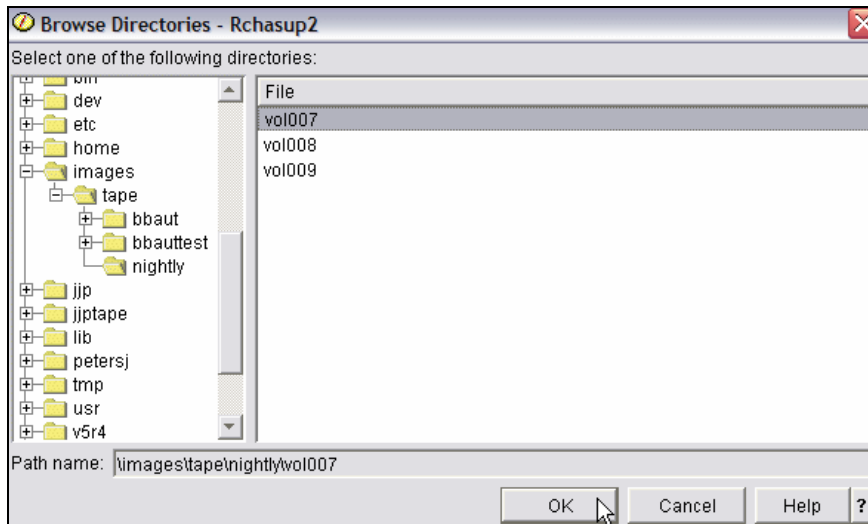

Figure 3-17 Files are displayed

This places the selected volume in the From tape image file box; see Figure 3-18.

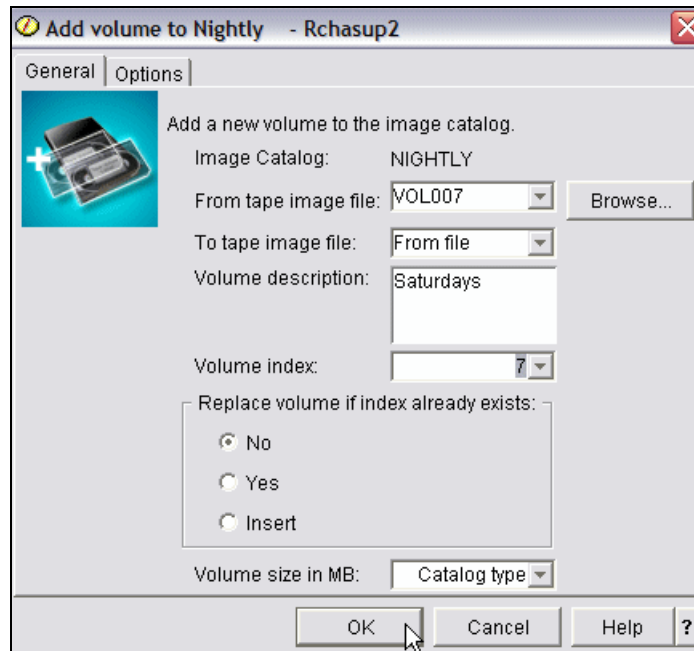

Figure 3-18 Parameters for adding existing volume

To add an existing virtual volume through 5250 emulation session, issue the ADDIMGCLGE command:

```
ADDIMGCLGE IMGCLG(Nightly) FROMFILE(Vo1007) TOFILE(*fromfile)
```

Figure 3-19 on page 55 shows the ADDIMGCLGE on a 5250 emulation session.

```

                                Add Image Catalog Entry (ADDIMGCLGE)

Type choices, press Enter.

Image catalog . . . . . > NIGHTLY      Name
From optical device, or . . . . .      Name
From image file . . . . . > Vo1007

To image file . . . . . > *fromfile

Image catalog index . . . . . *AVAIL      1-256, *AVAIL
Replace catalog entry . . . . . *NO      *NO, *YES, *INSERT
Text 'description' . . . . . Saturday nightly backups Vo1007

                                                                    Bottom
F3=Exit  F4=Prompt  F5=Refresh  F10=Additional parameters  F12=Cancel
F13=How to use this display  F24=More keys

```

Figure 3-19 Adding image catalog entry through 5250 emulation

Repeat this step for each file you want to add to your catalog. Note that this step assumes that your images already exist in the image catalog directory.

If the file exists in another directory, the full path of the image file must be listed in the FROMFILE parameter as shown in the following command:

```

ADDIMGCLGE IMGCLG(Nightly) FROMFILE(/Other_directory/subdirectory/Volume)
TOFILE(VOL007)

```

Figure 3-20 on page 56 shows the corresponding window.

```

Add Image Catalog Entry (ADDIMGCLGE)

Type choices, press Enter.

Image catalog . . . . . > NIGHTLY      Name
From optical device, or . . . . .      Name
From image file . . . . . > /Other_directory/subdirectory/volume

To image file . . . . . > Vol1007

Image catalog index . . . . . *AVAIL      1-256, *AVAIL
Replace catalog entry . . . . . *NO       *NO, *YES, *INSERT
Text 'description' . . . . . Saturday nightly backups Vol1007

Bottom

F3=Exit  F4=Prompt  F5=Refresh  F10=Additional parameters  F12=Cancel
F13=How to use this display  F24=More keys

```

Figure 3-20 Adding image from another directory through 5250 emulation

Repeat these steps for each file you want to add to your catalog.

### Load the image catalog in the virtual device

Select **Configuration and Service** → **Hardware** → **Tape Devices**, and right-click **Tape Image Catalogs**.

Next, right-click the image catalog and select **Load Image Catalog**, as shown in Figure 3-21 on page 57.

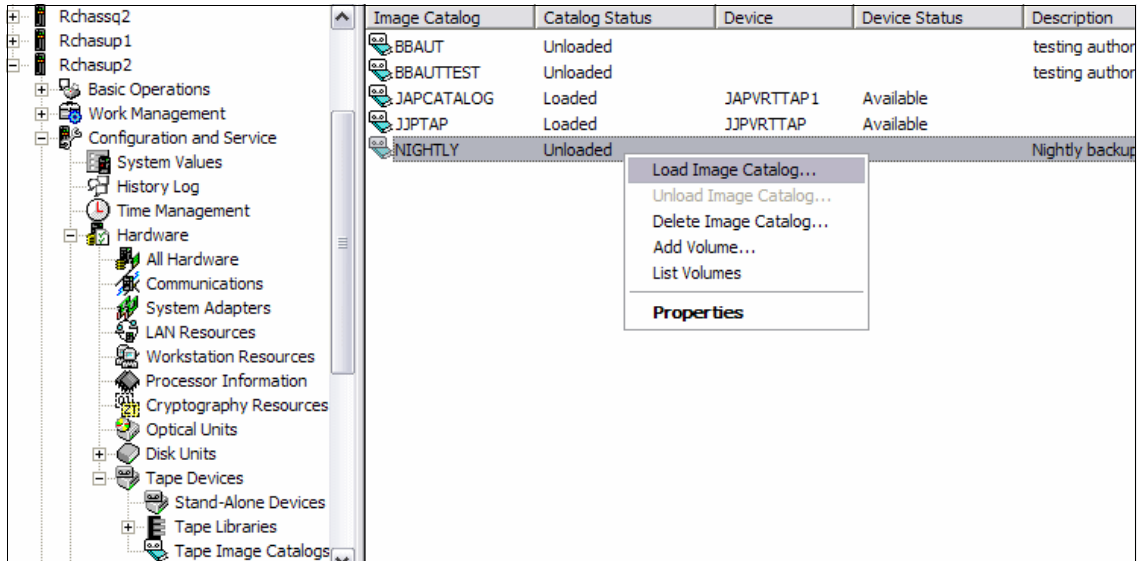

Figure 3-21 Loading image catalog through Navigator

To load your image catalog from a 5250 emulation session, issue the following command:

```
LODIMGCLG IMGCLG(MYCATALOG) DEV(TAPVRT01)
```

Figure 3-22 on page 58 shows the LODIMGCLG command and its parameters.

```

Load or Unload Image Catalog (LODIMGCLG)

Type choices, press Enter.

Image catalog . . . . . > NIGHTLY      Name
Virtual device . . . . . > TAPVRT01    Name
Option . . . . . *LOAD                 *LOAD, *UNLOAD
Write protect . . . . . *DFT            *DFT, *ALL, *NONE

Bottom
F3=Exit  F4=Prompt  F5=Refresh  F12=Cancel  F13=How to use this display
F24=More keys

```

Figure 3-22 Loading image catalog through 5250 emulation

Your virtual tape volume is now ready for operation in the same way as a physical tape volume that is loaded into a physical tape device.

## 3.2 Using a tape image catalog

This section discusses the basic steps involved in using a tape image catalog after it is created. This assumes that the volumes have been created and the image catalog's status is Loaded or Ready.

Select **Configuration and Service** → **Hardware** → **Tape Devices**, right-click **Tape Image Catalogs**, then right-click the image catalog and select **Properties**.

Under the General tab, the Catalog status should indicate Loaded, meaning the image catalog is loaded on to your virtual tape device. This is similar to a tape magazine being inserted back into a tape autoloader.

Figure 3-23 on page 59 shows the Catalog status, indicating the image catalog is Loaded.

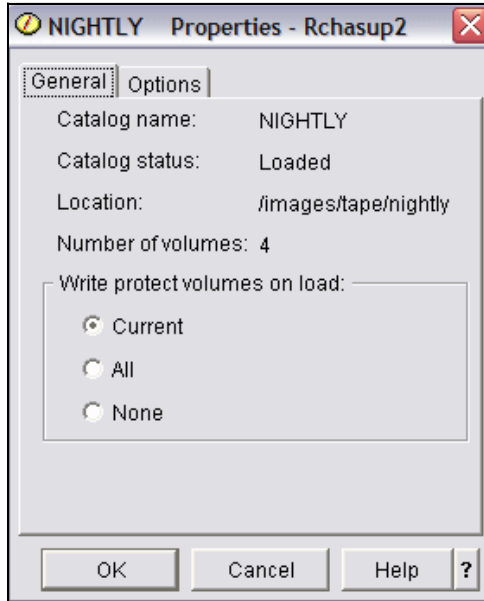

Figure 3-23 Image catalog properties through Navigator

Before performing a backup operation, ensure that the volume's status is Loaded in the tape image catalog. You can view the volumes by selecting **Configuration and Service** → **Hardware** → **Tape Devices**.

Then right-click **Tape Image Catalogs**, right-click the image catalog, and select **List Volumes**. You will see a window similar to the one shown in Figure 3-24 on page 60.

The screenshot shows a window titled 'List Volumes - Nightly - Rchasup2'. The window has a menu bar with 'File', 'Edit', 'View', and 'Help'. Below the menu bar is a toolbar with icons for cut, copy, paste, delete, and refresh. A status bar at the top right indicates '1 minutes old'. The main area contains a table with the following data:

In...	Volume Name	Status	Type	Density	Write Pro...	Percent Used	Maximum Size	File Name	Description
1	VOL001	Mounted	Standard labeled	*VRT256K	No	0.1	1,000	vol001	Sundays ni...
7	VOL007	Loaded	Standard labeled	*VRT256K	No	0.1	1,000	vol007	Saturdays

At the bottom of the window, a status bar indicates '1 - 2 of 2 objects'.

Figure 3-24 Listing volumes through Navigator

To verify the status of your image catalog and its volumes from a 5250 emulation screen, enter the following command:

```
WRKIMGCLGE IMGCLG(Nightly)
```

The screen should display Ready in the upper right-hand corner with at least one volume loaded and available, as shown in Figure 3-25 on page 61.

If it does not, add the volumes by following the steps described for ADDIMGCLGE, and ensuring that the image catalog is loaded on to the virtual device, using the LODIMGCLG command.

```

Work with Image Catalog Entries
                                     System:  RCHITSO
Catalog . . . : NIGHTLY              Status . . . : Ready
Type . . . . : Tape                  Device . . . : TAPVRT01
Directory . . : /images/tape/nightly

Type options, press Enter.
 1=Add  2=Change  4=Remove  6=Mount  8=Load  9=Unload
10=Initialize volume  11=Display  13=Dump  14=Duplicate

Opt  Index  Status      Volume Name  Density      Type  Write
      *AVAIL
      1  Mounted      VOL001      *VRT256K    *SL  No
      7  Loaded      VOL007      *VRT256K    *SL  No

                                     Bottom
F3=Exit  F5=Refresh      F6=Load image catalog  F8=Reorder by index
F11=View size information  F12=Cancel  F22=Display entire field

```

Figure 3-25 Verifying catalog status through 5250 emulation

Once your tape image catalog's status is Loaded or Ready, it behaves only as an Automatic Cartridge Loader (ACL) tape drive. The image catalog will automatically load/mount the next volume if the backup or restore spans multiple volumes.

Image catalogs are able to utilize volumes, whose status is Mounted or Loaded. If the volume's status is Unloaded, it is not used during operation.

You are now ready to save or restore using your image catalog.

### 3.2.1 Save using a tape image catalog

This basic example is provided to give you an idea about how to perform a simple save to the virtual storage. We also mention the parameters available for changing your virtual tape media to better fit your needs.

## Saving a library to virtual tape

The example described here involves saving a library (PRODLIB), to a newly added volume (VOL001), in the tape image catalog NIGHTLY, which is loaded in a device TAPVRT01.

Most virtual tape functions can be performed interactively or submitted to batch. This particular save is run interactively, to better demonstrate this example. For more information about interactive jobs, batch jobs, or backups in general, refer to the IBM @server iSeries Information Center, which is available on the Web at:

<http://publib.boulder.ibm.com/pubs/html/as400/infocenter.html>

In the IBM @server iSeries Navigator:

1. Right-click the system and select **Run Command**, as shown in Figure 3-26.

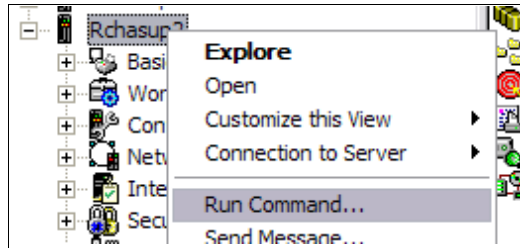

Figure 3-26 Issuing the run command through Navigator

2. Type SAVLIB against Command to run, and click **Prompt** to enter the parameters, as shown in Figure 3-27 on page 63.

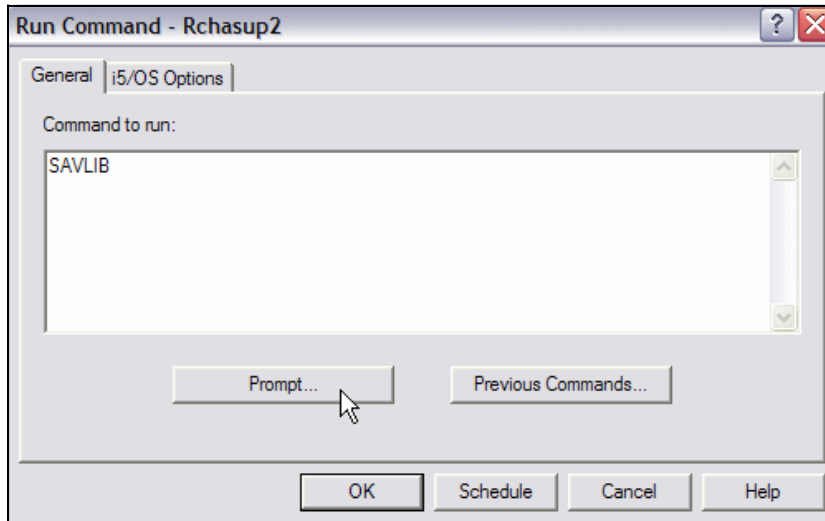

Figure 3-27 Saving library through Navigator

3. Enter the parameters:
  - a. Enter the library (in this case, PRODLIB) and click **Add**.
  - b. Enter the virtual tape device (in this case, TAPVRT01) and click **Add**.
  - c. Enter the volume (in this case, VOL001) and click **Add**. Then click **OK** in the prompt window; see Figure 3-28 on page 64.

**Note:** If your volume parameter is set to \*MOUNTED and no volume is in a mounted status, then the virtual tape device will mount the volume that is in the next index *after* the last volume that was mounted.

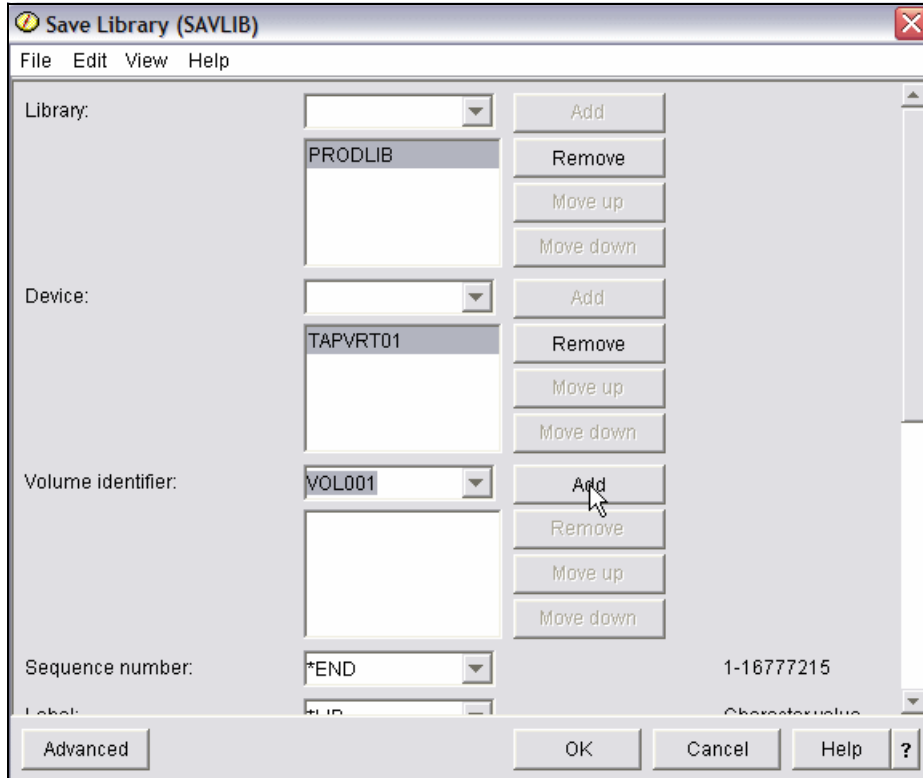

Figure 3-28 SAVLIB prompted through Navigator

4. Click **OK** in the Run Command window.

As you can see, there really is no difference in the parameter values when saving to a virtual device instead of a physical device. You tell the system to save to your image catalog by setting the DEVICE parameter to your virtual tape device (TAPVRT01).

The same save is performed from a 5250 emulation session with the following command:

```
SAVLIB LIB(PRODLIB) DEV(TAPVRT01) VOL(VOL001)
```

Figure 3-29 on page 65 shows the corresponding screen.

```

                                Save Library (SAVLIB)

Type choices, press Enter.

Library . . . . . > PRODLIB      Name, generic*, *NONSYS...
      + for more values
Device . . . . . > TAPVRT01     Name, *SAVF, *MEDDFN
      + for more values
Volume identifier . . . . . Vol1001
      + for more values
Sequence number . . . . . *END      1-16777215, *END
Label . . . . . *LIB
File expiration date . . . . . *PERM      Date, *PERM
End of media option . . . . . *REWIND   *REWIND, *LEAVE, *UNLOAD
Starting library . . . . . *FIRST      Name, *FIRST
Use optimum block . . . . . *YES       *YES, *NO

                                                                 Bottom
F3=Exit  F4=Prompt  F5=Refresh  F10=Additional parameters  F12=Cancel
F13=How to use this display  F24=More keys

```

Figure 3-29 SAVLIB prompted through 5250 emulation

You save to a virtual tape by specifying the virtual tape device where the image catalog is loaded.

**Note:** If your Volume (VOL) parameter is set to \*MOUNTED and no volume is in a mounted status, the virtual tape device will mount the volume that is in the next index *after* the last volume that was mounted.

### 3.2.2 Automatic creation of new volumes

This section describes the auto create feature of virtual volumes.

When the End of Volume (EOV) marker is reached during a backup and there no more volumes are available in the image catalog, you will receive a message. If you are using a volume list, you will receive a CPA6798 message, as shown in Example 3-1 on page 66.

*Example 3-1 CPA6798 message text*

---

Message . . . . : No volume to mount on device &1. (C "cartridge id")  
Cause . . . . . : Either all of the volumes specified in the volume list for  
the operation have been used or a tape management exit program did not supply a  
volume to mount.  
Recovery . . . . : Type C to cancel processing, or enter the name of a tape  
cartridge to be used next.

---

If you reply: C to cancel the job will end, since no more volumes are available. If  
you reply: cartridge id, an initialized volume will automatically be created in  
your image catalog. The volume ID should not already exist in the tape image  
catalog.

If you specify \*MOUNTED for the Volume (VOL) parameter, a volume is  
automatically created and message CPF4901 is issued, as shown in Example  
3-2.

*Example 3-2 CPF4901 message text*

---

Message . . . . : End of volume detected for file &2 in &3.  
Cause . . . . . : End of volume was detected for file &2 in library &3. The  
next volume that is inserted on device &4 has volume identifier &7.  
Possible choices for replying to message . . . . . :  
    G -- Continue processing  
    C -- Cancel processing of the file

---

The default reply for CPF4901 is G.

If a volume is auto-created, it will be created with the following defaults:

- ▶ ADDIMGCLGE IMGCLG (same as previous volume)
- ▶ FROMFILE(\*NEW)
- ▶ TOFILE(\*GEN)
- ▶ IMGCLGIDX (last available index) - backwards from 256
- ▶ REPLACE(\*NO)
- ▶ IMGSIZ(\*IMGCLGTYPE)
- ▶ ALCSTG(\*MIN)
- ▶ VOLNAM(\*GEN)
- ▶ VOLTYP (same as previous volume)
- ▶ DENSITY (same as previous volume)
- ▶ NEWOWNID (same as previous volume)
- ▶ CODE (same as previous volume)

### 3.2.3 Viewing the virtual volumes

This section shows you how to view the volumes that exist in the image catalog and the contents of the volumes.

- ▶ Viewing the volumes in the image catalog

To see all the volumes that your image catalog contains, select **Configuration and Service** → **Hardware** → **Tape Devices** → **Tape Image Catalogs**. Then right-click the image catalog and select **List Volumes**.

From the window shown in Figure 3-30, you can see all the volumes in your image catalog. It also displays the following information:

- Index number (IMGCLGIDX)
- Volume name (VOLNAM)
- Volume status
- Volume type (TYPE)
- Density (DENSITY)
- Write protect (WRTPTC)
- Percent used (of maximum size)
- Maximum size (IMGSIZ)
- File name (TOFILE)
- Description (TEXT)

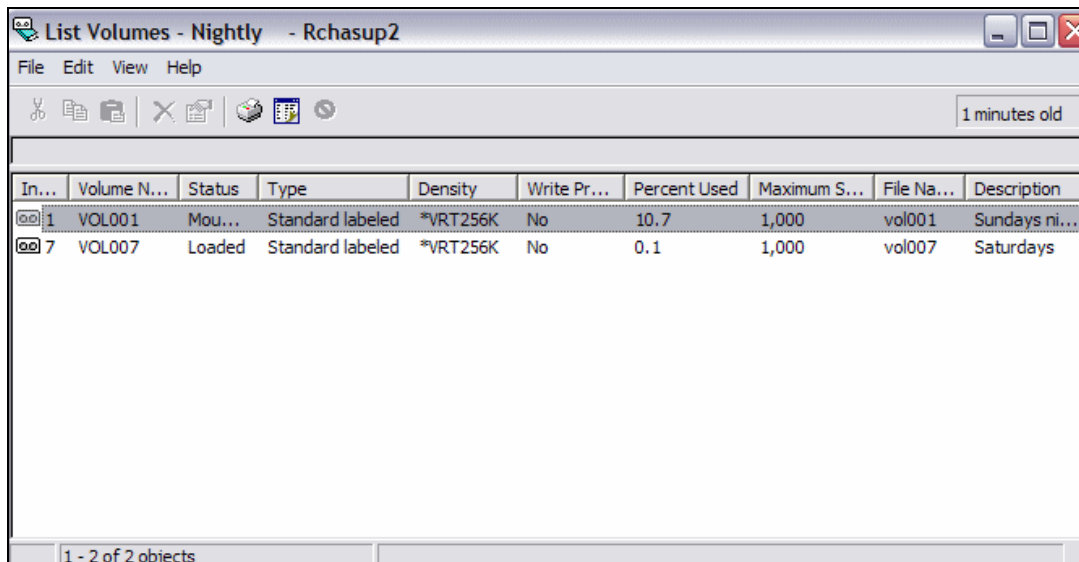

In...	Volume N...	Status	Type	Density	Write Pr...	Percent Used	Maximum S...	File Na...	Description
1	VOL001	Mou...	Standard labeled	*VRT256K	No	10.7	1,000	vol001	Sundays ni...
7	VOL007	Loaded	Standard labeled	*VRT256K	No	0.1	1,000	vol007	Saturdays

Figure 3-30 List volumes through Navigator

► Viewing the volume contents

To verify whether the save is complete, review the joblog. However, if you want to view the contents in the volume, from the iNav navigation panel, select **Configuration and Service** → **Hardware** → **Tape Devices**. Then right-click the tape device and select **Display Volume Labels** to display to the screen shown in Figure 3-31.

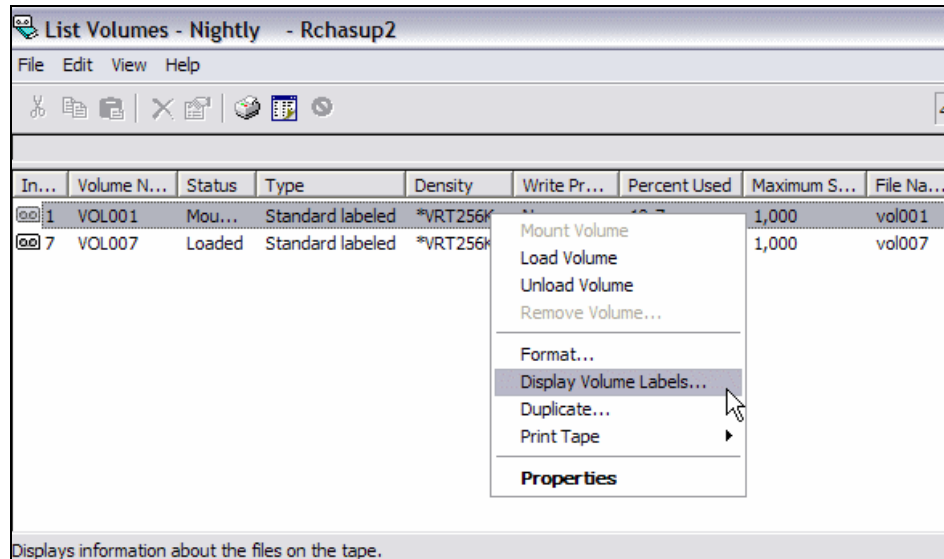

Figure 3-31 Display volume labels through Navigator

In the Display Volume labels for Tapvrt01, shown in Figure 3-32 on page 69, select the Options tab.

From the two pull-down menus (see Figure 3-33 on page 70), define the sequence numbers to be displayed.

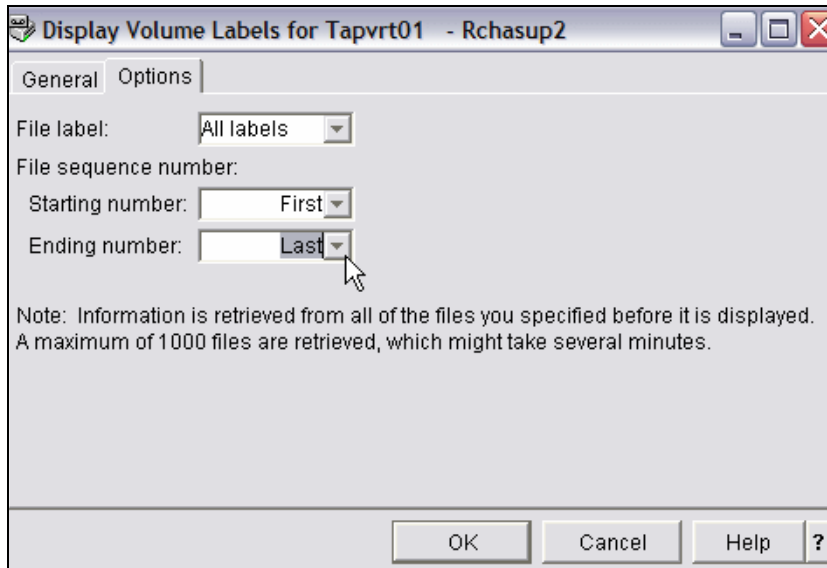

Figure 3-32 Display volume label options through Navigator

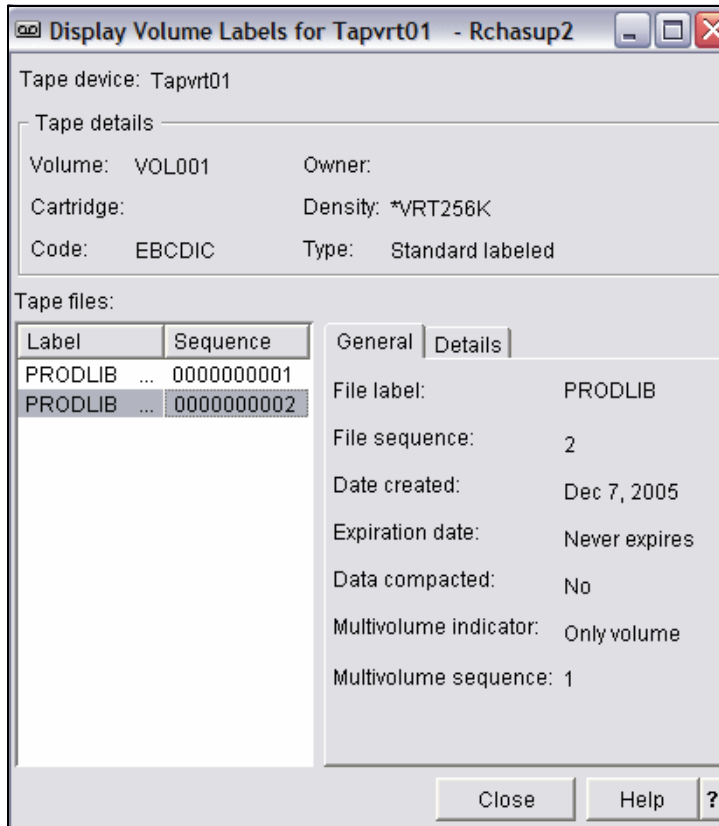

Figure 3-33 Volume labels through Navigator - second screen

Alternatively, you can view information by displaying a printed output. From the iNav navigation panel, select **Configuration and Service** → **Hardware** → **Tape Devices**. Next, right-click the tape device and select **Print Tape** to display the screen shown in Figure 3-34 on page 71. Then select **Save/Restore information**. This produces a print file that you can view by selecting **Basic Operations** → **Printer Output**.

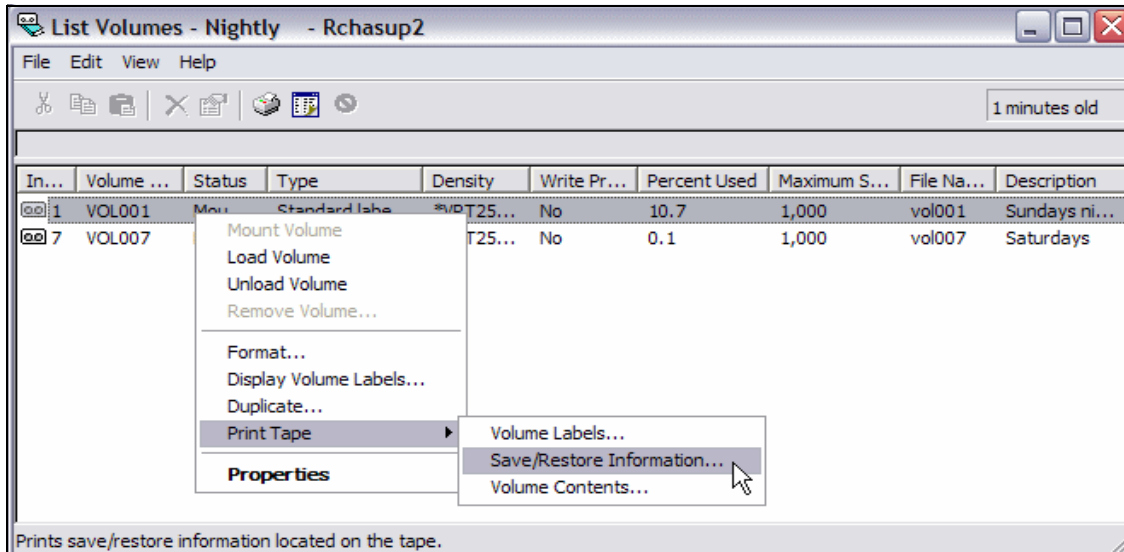

Figure 3-34 Print volume save/restore through Navigator

Figure 3-35 shows the display for printing volume information through Navigator. The volume information is displayed, as well as the default end of tape action. Typically you would accept the defaults, check the box Display printer output, and click **OK**.

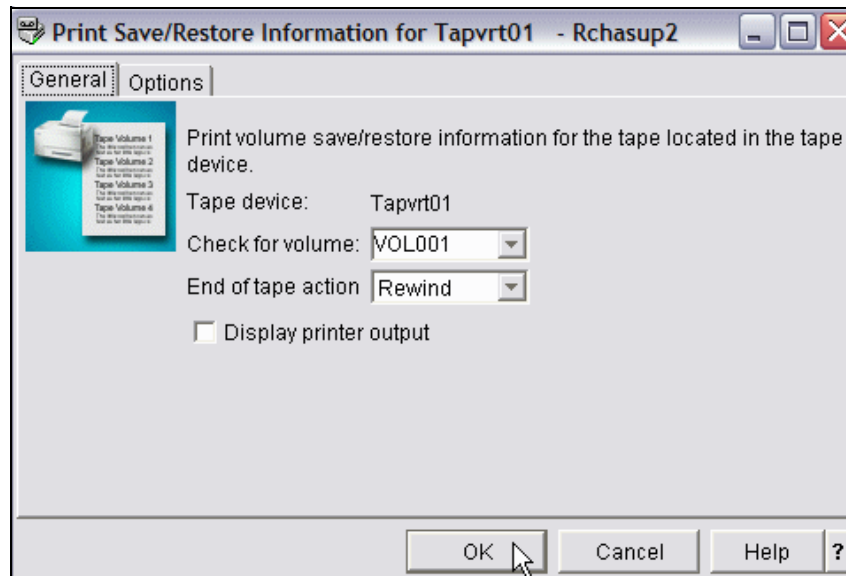

Figure 3-35 Print volume information through Navigator

Figure 3-36 shows the display for volume save/restore output through Navigator.

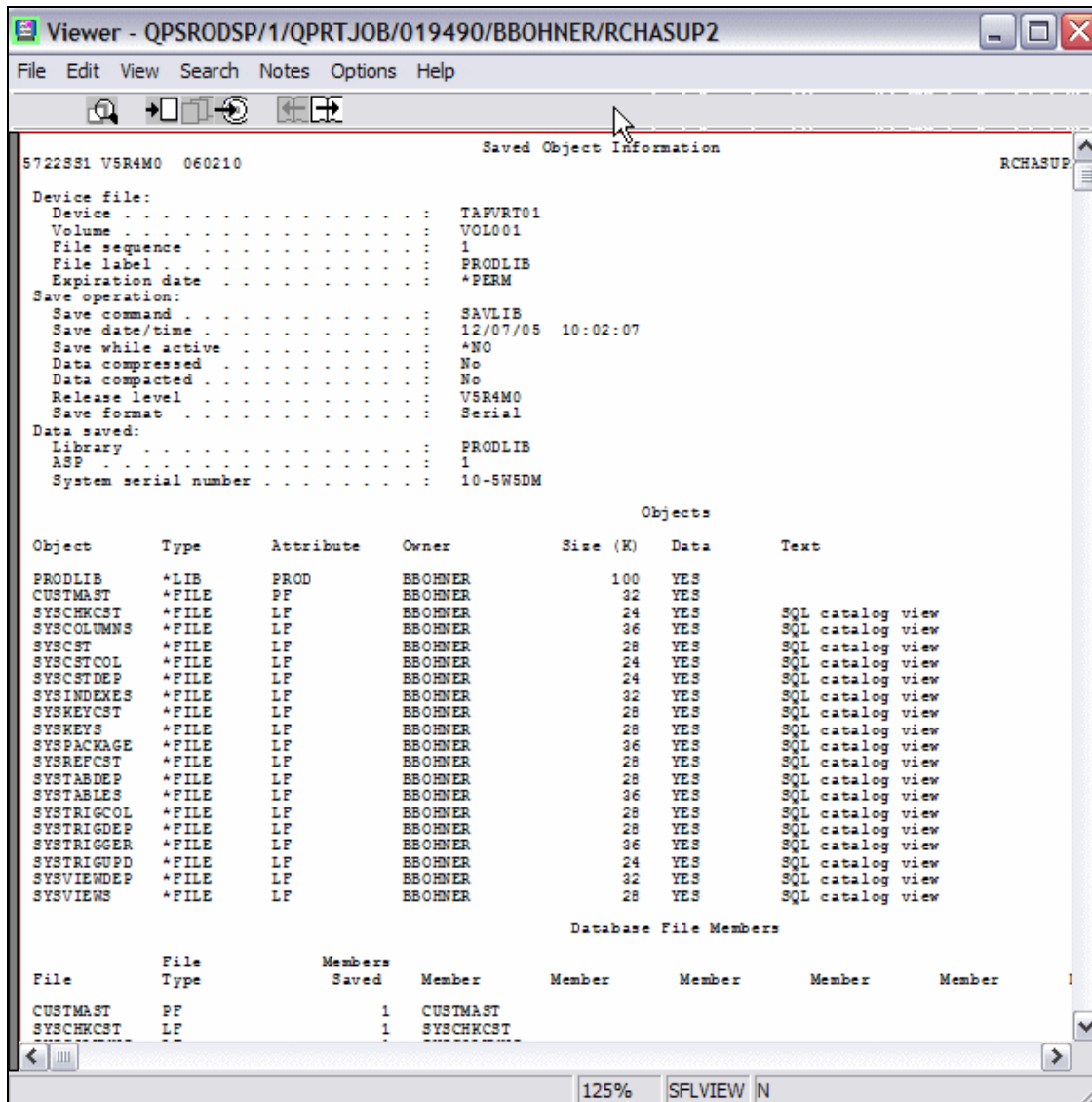

Figure 3-36 Volume save/restore output through Navigator

**Note:** The maximum size of the image file is 1000 MB. However, the storage used is 10.7%, or 107 MB. This can be verified by selecting **File Systems** → **Integrated File Systems** → **Root**, and then selecting the directory of your image catalog and its image files. Right-click the image file, select **Properties**, and click **Storage**. This lists both the size of the data (the size of only the saved data) and the allocated size (the size reserved and used only for this virtual volume).

If the allocated size is significantly larger than the data size and it has to be freed up for other functions to utilize, then shrink the allocated storage by changing the Allocate Storage (ALCSTG) parameter value to \*MIN.

Refer to 3.2.4, “Changing virtual media characteristics” on page 79 for more information about virtual media characteristics.

You can also view the volumes in your image catalog from a 5250 emulation session. To do this, use the WRKIMGCLGE command:

```
WRKIMGCLGE IMGCLG(NIGHTLY)
```

Figure 3-37 on page 74 shows the resulting screen.

```

                                Work with Image Catalog Entries
                                System:  RCHITSO
Catalog . . . :  NIGHTLY           Status . . . :  Ready
Type . . . . :  Tape              Device . . . :  TAPVRT01
Directory . . :  /images/tape/nightly

Type options, press Enter.
 1=Add  2=Change  4=Remove  6=Mount  8=Load  9=Unload
10=Initialize volume  11=Display  13=Dump  14=Duplicate

Opt  Index  Status      Volume Name  Density      Type  Write
      *AVAIL
      1  Mounted      VOL001      *VRT256K    *SL  No
      7  Loaded      VOL007      *VRT256K    *SL  No

                                Bottom
F3=Exit  F5=Refresh      F6=Load image catalog  F8=Reorder by index
F11=View size information  F12=Cancel  F22=Display entire field

```

Figure 3-37 Work with virtual volumes through 5250 emulation

Use F11 to view the size information, as follows:

- ▶ Pressing F11 displays additional information about the volumes in the window. This includes the maximum size (IMGSIZ) and percent used of the maximum size.
- ▶ Pressing F11 again shows the text description.
- ▶ Pressing F11 a third time displays the image file name.

Figure 3-38 on page 75 shows the WRKIMGCLGE window after F11 is pressed once.

```

Work with Image Catalog Entries
                                     System:  RCHITSO
Catalog . . . : NIGHTLY               Status . . . : Ready
Type . . . . : Tape                   Device . . . : TAPVRT01
Directory . . : /images/tape/nightly

Type options, press Enter.
 1=Add  2=Change  4=Remove  6=Mount  8=Load  9=Unload
10=Initialize volume  11=Display  13=Dump  14=Duplicate

Opt  Index  Status      Volume Name      Maximum  Percent
      *AVAIL
      1  Mounted      VOL001           1000     10.7
      7  Loaded      VOL007           1000      .1

                                     Bottom

F3=Exit  F5=Refresh  F6=Load image catalog  F8=Reorder by index
F11=View descriptions  F12=Cancel  F22=Display entire field

```

Figure 3-38 Volumes additional information through 5250 emulation

Figure 3-38 shows that the per cent used is 10.7%. This is the per cent used of the Maximum Size (IMGSIZ) of 1000 MB.

**Note:** The maximum size of the image file is 1000 MB. However, the actual storage used is 10.7%, or 107 MB. This can be verified by using WRKLNK for the directory path of the object, and then selecting option **8=Display Attributes on the actual Image file** (STMF) in the IFS directory. This lists the size of the data (the size of only the saved data) and the allocated space (the size reserved and used only for this virtual volume).

If the allocated size is significantly larger than the data size and it has to be freed up for other functions to utilize, shrink the allocated storage down by changing the Allocate Storage (ALCSTG) parameter's value to \*MIN.

Refer to 3.2.4, "Changing virtual media characteristics" on page 79 for more information about virtual media characteristics.

Figure 3-39 shows using WRKLNK and 8=Display attributes. You can see that the allocated storage size is much larger than the data storage size.

```
Display Attributes

Object . . . . . : /images/tape/nightly/vol001

Creation date/time . . . . . : 12/06/05 22:42:37
Last access date/time . . . . . : 12/07/05 14:08:23
Data change date/time . . . . . : 12/07/05 14:08:23
Attribute change date/time . . . . . : 12/07/05 14:08:23

Size of object data in bytes . . . . . : 112251040
Allocated size of object . . . . . : 168563246
File format . . . . . : *TYPE2
Size of extended attributes . . . . . : 0
Storage freed . . . . . : No
Disk storage option . . . . . : *DYNAMIC
Main storage option . . . . . : *DYNAMIC

Auditing value . . . . . : *NONE

More...

Press Enter to continue.

F3=Exit F12=Cancel F22=Display entire field
```

Figure 3-39 Display attributes through 5250 emulation

When viewing the volume information from a 5250 emulation session, it can only be viewed one sequence at a time if displayed on the screen. Therefore, it is usually best to print it to a spool file.

Enter the following DSPTAP command to view the volume information from a 5250 emulation session:

```
DSPTAP DEV(NIGHTLY) VOL(VOL001) OUTPUT(*PRINT)
```

Figure 3-40 on page 77 shows the corresponding window.

```

                                Display Tape (DSPTAP)

Type choices, press Enter.

Device . . . . . Nightly           Name
Volume identifier . . . . . vol001   Character value, *MOUNTED
File label . . . . . *ALL
Sequence number:
  Starting file sequence number *FIRST   1-16777215, *ALL, *FIRST
  Ending file sequence number . *LAST    1-16777215, *ONLY, *LAST
Data type . . . . . *LABELS         *LABELS, *SAVRST
Output . . . . . *PRINT              *, *PRINT, *OUTFILE
End of tape option . . . . . *REWIND   *REWIND, *UNLOAD

                                                    Bottom
F3=Exit  F4=Prompt  F5=Refresh  F12=Cancel  F13=How to use this display
F24=More keys

```

Figure 3-40 Volume labels through 5250 emulation

This displays the volume labels as shown in Figure 3-41.

```

DSPTAPLabels.txt - Notepad
File Edit Format View Help
                                Display Spooled File
File . . . . . : QPTAPDSP                                Page/Line 1/1
Control . . . . :                                         Columns 1 - 130
Find . . . . . :
". . . . . 1 . . . . . 2 . . . . . 3 . . . . . 4 . . . . . 5 . . . . . 6 . . . . . 7 . . . . . 8 . . . . . 9 . . . . . 0 . . . . . 1 . . . . . 2 . . . . . 3
572255L V5R4M0 060210          TAPE VOLUME INFORMATION  VOL001  VOL001  RCHASUP2  12/07/05 13:35:34  Page 1
Device . . . . . : TAPVRT01          Volume . . . . . : VOL001  VOL001
Owner ID . . . . . :                 Density . . . . . : *VRT256K
Type . . . . . : *SL                 Code . . . . . : *EBCDIC

Data File Label  File      Record  Recg  Record  Block  File      Mvol  Mvol  Date      Expiration  System
                  Sequence  Format  Tech  Length  Length Length  Ind  Sequence  Created  Date  Where Created
PRODLIB          000000001 *U      00000  262144 0000000003 0000000001 12/07/05 *PERM  IBMOS400
PRODLIB          000000002 *U      00000  262144 0000000431 0000000001 12/07/05 *PERM  IBMOS400
***** END OF LISTING *****

                                                    Bottom
F3=Exit  F12=Cancel  F19=Left  F20=Right  F24=More keys

```

Figure 3-41 Output of volume labels through 5250 emulation

Enter the following command to display the save/restore information from a 5250 emulation session:

```
DSPTAP DEV(TAPVRT01) VOL(VOL001) DATA(*SAVRST) OUTPUT(*PRINT)
```

Figure 3-42 shows the corresponding window.

```
Display Tape (DSPTAP)

Type choices, press Enter.

Device . . . . . > TAPVRT01      Name
Volume identifier . . . . . > VOL001      Character value, *MOUNTED
File label . . . . . *ALL
Sequence number:
  Starting file sequence number *FIRST      1-16777215, *ALL, *FIRST
  Ending file sequence number . *LAST      1-16777215, *ONLY, *LAST
Data type . . . . . > *SAVRST      *LABELS, *SAVRST
Output . . . . . > *PRINT      *, *PRINT, *OUTFILE
End of tape option . . . . . *REWIND      *REWIND, *UNLOAD

Bottom

F3=Exit  F4=Prompt  F5=Refresh  F12=Cancel  F13=How to use this display
F24=More keys
```

Figure 3-42 Display of save/restore information through 5250 emulation

This displays the output of save/restore information as shown in Figure 3-43.

```

File . . . . . : QPSRODSP                               Page/Line 1/1
Control . . . . :                                       Columns 1 - 130
Find . . . . . :
*...+...1...+...2...+...3...+...4...+...5...+...6...+...7...+...8...+...9...+...0...+...1...+...2...+...3
          Saved Object Information                               Page 1
5722SS1 V5R4M0 060210                                       RCHASUP2 12/07/05 13:57:25 CST
Device file:
Device . . . . . : TAPVRT01
Volume . . . . . : VOL001
File sequence . . . . . : 1
File label . . . . . : PRODLIB
Expiration date . . . . . : *PERM
Save operation:
Save command . . . . . : SAVLIB
Save date/time . . . . . : 12/07/05 10:02:07
Save while active . . . . . : *NO
Data compressed . . . . . : No
Data compacted . . . . . : No
Release level . . . . . : V5R4M0
Save format . . . . . : Serial
Data saved:
Library . . . . . : PRODLIB
ASP . . . . . : 1
More...

F3=Exit F12=Cancel F19=Left F20=Right F24=More keys
System serial number . . . . . : 10-5W5DM

Object Type Attribute Owner Size (K) Data Text
PRODLIB *LIB PROD BBOHNER 100 YES
CUSTMAST *FILE PF BBOHNER 32 YES
SYSCCHKCST *FILE LF BBOHNER 24 YES
SYSCOLUMNS *FILE LF BBOHNER 36 YES
SYSCST *FILE LF BBOHNER 28 YES
SYSCSTCOL *FILE LF BBOHNER 24 YES
SYSCSTDEP *FILE LF BBOHNER 24 YES
SYSINDEXES *FILE LF BBOHNER 32 YES
SYSKEYCST *FILE LF BBOHNER 28 YES
SYSKEYS *FILE LF BBOHNER 28 YES
SYSPACKAGE *FILE LF BBOHNER 36 YES
SYSREFCST *FILE LF BBOHNER 28 YES
SYSTABDEP *FILE LF BBOHNER 28 YES
SYSTABLES *FILE LF BBOHNER 36 YES
SYSTRIGCOL *FILE LF BBOHNER 28 YES
  
```

Figure 3-43 Display output of save/restore information through 5250 emulation

### 3.2.4 Changing virtual media characteristics

This section reviews some of the options available in changing the characteristics of virtual media. These changes provide you with more flexibility. The values chosen can affect many things, including the following:

- ▶ Amount of space allocated, that is, image size and allocate storage
- ▶ Performance, that is, allocate storage
- ▶ Organization, that is, volume index
- ▶ Security, that is, write protect

#### Changing the image catalog entry

To make changes to the characteristics of your virtual media through IBM @server iSeries Navigator, do the following.

Select **Configuration and Service** → **Hardware** → **Tape Devices** → **Tape Image Catalogs**. Then right-click the image catalog and select **List Volumes** as shown in Figure 3-44 on page 80.

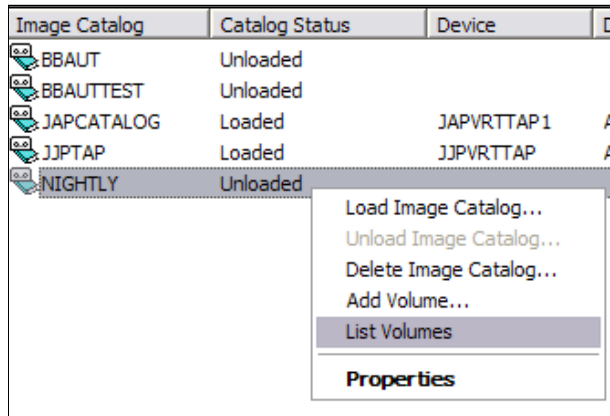

Figure 3-44 List image catalog volumes through Navigator

Next, right-click your volume and select **Properties**, as shown in Figure 3-45.

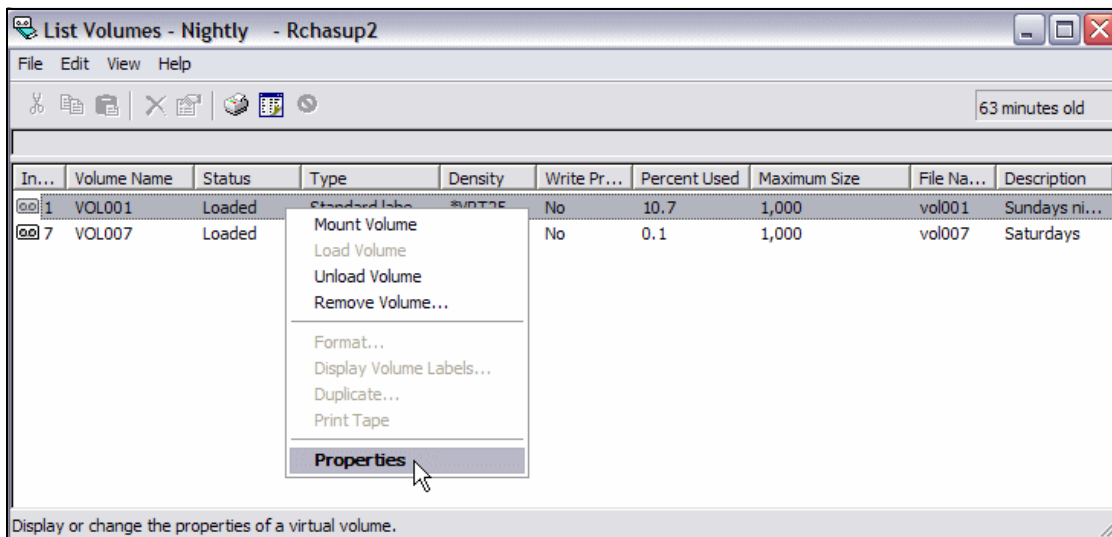

Figure 3-45 Volume properties selected through Navigator

This displays a window containing the General tab and the Options tab.

Figure 3-46 on page 81 shows the window that appears when you click the General tab.

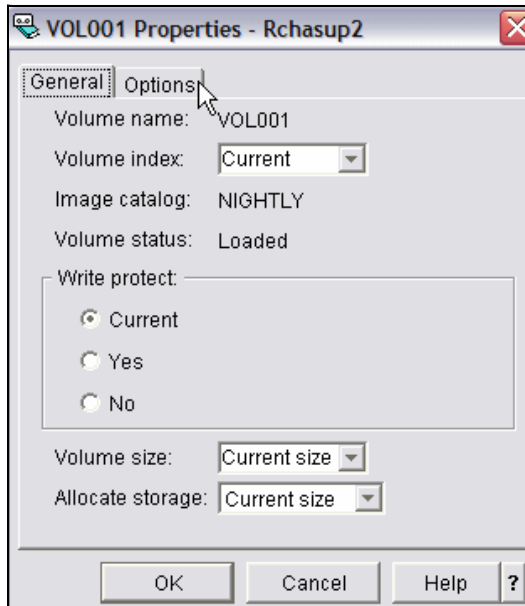

Figure 3-46 Volume properties (General) through Navigator

Figure 3-47 on page 82 shows the window that appears when you click the Options tab.

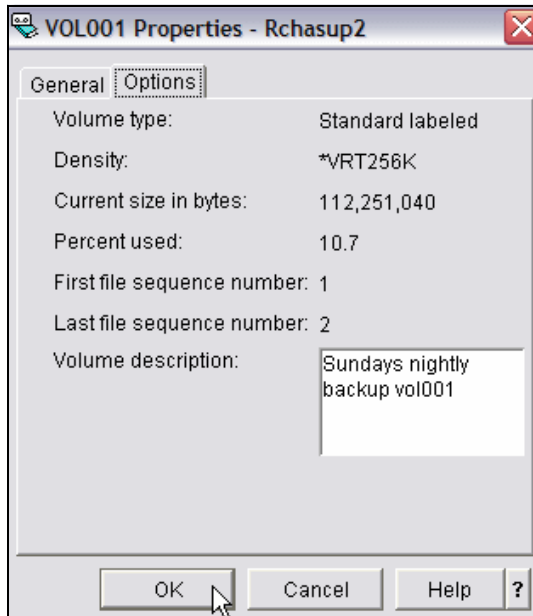

Figure 3-47 Volume properties (Optional) through Navigator

If you are viewing from a 5250 emulation session, the volume characteristics can be viewed with the Work with Image Catalog Entries (WRKIMGCLGE) command. Pressing Enter and pressing F11 up to three times shows the volume characteristics.

Figure 3-48 on page 83 shows the first screen of the volume characteristics in the Work with Image Catalog Entries window on a 5250 emulation session.

```

Work with Image Catalog Entries
                                System:  RCHITSO
Catalog . . . : NIGHTLY           Status . . . : Not ready
Type . . . . : Tape               Device . . . :
Directory . . : /images/tape/nightly

Type options, press Enter.
 1=Add  2=Change  4=Remove  6=Mount  8=Load  9=Unload
10=Initialize volume  11=Display  13=Dump  14=Duplicate

Opt  Index  Status      Volume Name  Density      Type  Write
     *AVAIL
     1  Loaded      VOL001      *VRT256K    *SL  No
     7  Loaded      VOL007      *VRT256K    *SL  No

                                Bottom
F3=Exit  F5=Refresh      F6=Load image catalog  F8=Reorder by index
F11=View size information  F12=Cancel  F22=Display entire field

```

Figure 3-48 Volume characteristics through 5250 emulation

From Volume Properties in IBM @server iSeries Navigator or the Work with Image Catalog Entries window on a 5250 emulation session, you can change the following:

► Volume Index (NEWCLGIDX)

This specifies a new index number to be used for the image catalog entry. If an entry currently exists at the specified index location, the new entry will be inserted and all entries at or below the specified index number will be incremented by 1. This determines which order your volumes are located in the image catalog.

- Current (\*SAME): The index number will not be changed.
- 1-256: Specifies the image catalog index number to be used.

► Write-protect (WRTPTC)

This specifies whether this catalog entry should be write-protected or not. No write operations will be allowed to this catalog entry if you write-protect it. This parameter cannot be changed while the volume's status is Mounted.

This parameter is not allowed for reference or dependent image catalogs.

- Current (\*SAME): The value for write-protect will not be changed.
- Yes (\*YES): This specifies that this catalog entry is to be write-protected. This will prevent write operation from being carried out.
- No (\*NO): This specifies that this catalog entry is not to be write-protected. This will allow write operations to be done to this catalog entry.

► Volume size (IMGSIZ)

This specifies the maximum size allowed for this tape image file. If the specified image size is larger than the current file size, the new maximum size is set and the file size is increased. If the specified size is smaller than the current maximum image size and the data stored in the image file is less than the specified value, the file will be reduced to the specified size. Otherwise, the command will fail.

This parameter is only allowed for tape type image catalogs, and not for reference or dependent image catalogs.

- Minimum size (\*MIN): The allocated image file size is truncated or shrunk to the size of the data stored in the file.
- 48-1000000: This specifies the maximum number of megabytes allowed for this tape image file.

► Storage allocation

This specifies whether to allocate the entire amount of storage specified on the image size (IMGSIZ) parameter for tape image files.

This parameter is only allowed for tape type image catalogs. This value cannot be changed while the volume's status is Mounted. This parameter is not allowed for reference or dependent image catalogs.

- Minimum size (\*MIN): This specifies changing storage allocation to match the storage required to contain the existing image file data. If performing a save, the image file size is increased dynamically. However, the image file size will not increase once the system reaches 5% or 5 GB storage remaining, whichever is the lesser value.

This value is not valid for reference or dependent catalogs (that is, catalog shadowing).

- Image size (\*IMGSIZ): This specifies changing the storage allocation to match the size of storage for this image file. This is the value that was specified in the image size (IMGSIZ) parameter of the ADDIMGCLGE command.

Earlier, after saving a library to the virtual volume, you saw that the volume took up 10.7% of 1000 MB, the maximum size, allocated for that virtual volume. The amount of 10.7% means that 107 MB of actual data (that is,

112 MB, including the image file and its information) is contained on the system. In the earlier example, the ALCSTG was not changed. Therefore, it will dynamically allocate space as needed. This means that it allocates 107 MB of space plus any extra space it may have allocated.

In the example, the Properties tab shows that 160 MB is allocated. However, if the Allocate Storage (ALCSTG) was set to Image Size (\*IMGSIZ) then, since the maximum size is 1000 MB, the system will still keep the other 893 MB of allocated space so that it cannot be used for anything else except saving to this specific virtual volume.

If you do not wish to preallocate this full space or any extra space for this virtual volume, the proper way to deallocate this extra space and still allow for the volume to write up to a total of 1000 MB is to change the allocation to the Minimum size, that is, ALCSTG(\*MIN).

## Changing the virtual volume

This section shows you how to move the volume to a different index or slot, make the volume write-protected, change the volume description, and truncate or shrink the volume's allocated size down to the actual size of the data.

**Note:** Allocate Storage (ALCSTG) and Write Protect (WRTPTC) cannot be changed when the volume's status is Mounted.

In the earlier example, a virtual volume was described as having the following attributes:

- ▶ Volume index (IMGCLGIDX): 1
- ▶ Write Protect (WRTPTC): No
- ▶ Volume Description (TEXT): Sundays nightly backup vol001
- ▶ Maximum size (IMGSIZ): 1000 MB
- ▶ Allocate Storage (ALCSTG): Minimum storage
- ▶ Data storage: 107 MB (112 MB total)
- ▶ Dynamically allocated size (currently): 168 MB

If you want to change the index, write protection, description, and shrink the allocated size of the virtual volume down to the size of the data saved, select **Configuration and Service** → **Hardware** → **Tape Devices** → **Tape Image Catalogs**. Then right-click the image catalog, select **List Volumes** and right-click the volume and select **Properties**. From Volume Properties, the volume's characteristics can be changed.

Figure 3-49 on page 86 shows the use of IBM @server iSeries Navigator for changing the characteristics in the General tab.

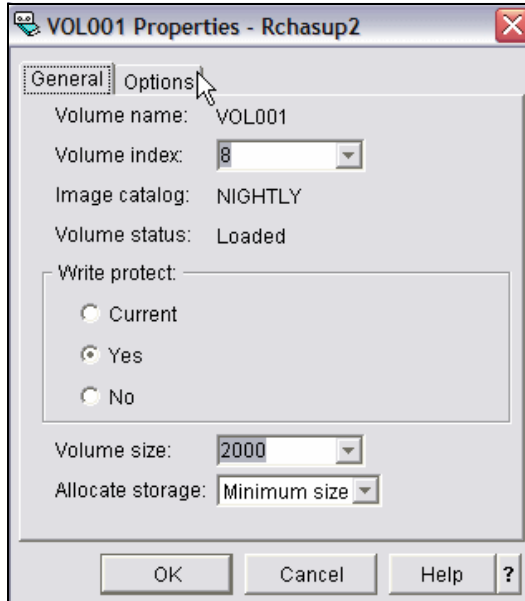

Figure 3-49 Change volume properties (General) through Navigator

Figure 3-50 on page 87 shows the use of IBM @server iSeries Navigator for changing the characteristics in the Option tab.

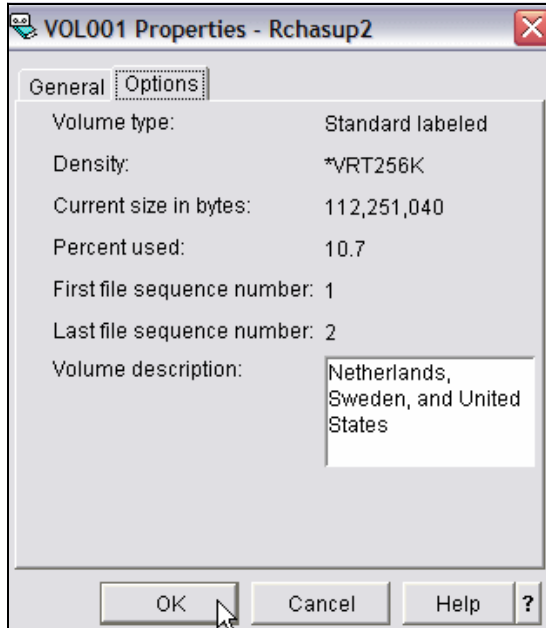

Figure 3-50 Change volume properties (optional) through Navigator

Following are the changes/results:

- ▶ Volume index (IMGCLIDX): 8
- ▶ Write Protect (WRTPTC): Yes
- ▶ Volume Description (TEXT): Netherlands, Sweden, and United States
- ▶ Maximum size (IMGSIZ): 2000 MB
- ▶ Allocate Storage (ALCSTG): Minimum storage
- ▶ Data storage: 107 MB (112 MB total)
- ▶ Dynamically allocated size (currently): 112 MB

Changes to the characteristics of the virtual media through a 5250 emulation session can be performed with the Change Image Catalog Entry (CHGIMGCLGE) command.

From the Change Image Catalog Entry (CHGIMGCLGE) window, you can change the text description as well as the catalog index, write protection, maximum image size, and how the storage is allocated for the virtual volume.

Figure 3-51 on page 88 shows the corresponding window.

```

Change Image Catalog Entry (CHGIMGCLGE)

Type choices, press Enter.

Image catalog . . . . . > NIGHTLY      Name
Image catalog index . . . . . > 2      1-256, *VOL
New catalog index . . . . . > 8      1-256, *SAME
Write protect . . . . . > *YES      *SAME, *YES, *NO
Image size . . . . . 2000      *SAME, 48-1000000 megabytes
Allocate storage size . . . . . > *MIN      *SAME, *MIN, *IMGSIZ
Text 'description' . . . . . 'Netherlands, Sweden, and United States'

Bottom
F3=Exit  F4=Prompt  F5=Refresh  F12=Cancel  F13=How to use this display
F24=More keys

```

Figure 3-51 Change volume attributes through 5250 emulation

The volume is now at index 8, it is write-protected, and has 112 MB of storage allocated, out of a maximum storage capacity of 2000 MB.

By displaying the attributes of the stream file, you can see in Figure 3-52 on page 89 that the allocated storage went down from 168 MB to 112 MB.

```

                                Display Attributes

Object . . . . . : /images/tape/nightly/vol001

Creation date/time . . . . . : 12/06/05 22:42:37
Last access date/time . . . . . : 12/07/05 18:56:13
Data change date/time . . . . . : 12/07/05 18:56:13
Attribute change date/time . . . . . : 12/07/05 18:56:13

Size of object data in bytes . . . . . : 112251040
Allocated size of object . . . . . : 112459776
File format . . . . . : *TYPE2
Size of extended attributes . . . . . : 0
Storage freed . . . . . : No
Disk storage option . . . . . : *DYNAMIC
Main storage option . . . . . : *DYNAMIC

Auditing value . . . . . : *NONE

                                                                    More...

Press Enter to continue.

F3=Exit  F12=Cancel  F22=Display entire field

```

Figure 3-52 Stream file changed attributes through 5250 emulation

### 3.3 Copying virtual tape to physical tape

This section discusses the methods for copying virtual tape to physical tapes.

Although virtual tape offers many benefits, it is very important to copy the virtual tape volumes to physical tapes as soon as possible in order to preserve the data in the event of a disaster, where the system or DASD disk drives are no longer accessible.

Most commonly, you will want to duplicate the exact copy of your virtual tape image to a physical volume. This section also discusses copying a portion of the virtual backup to tape and copying the tape image to tape, where it can be restored only as an entire image later.

### 3.3.1 Preparing for duplication

This section describes how to check that the volumes are ready for duplication. Before copying or duplicating a volume, do the following:

1. Decide which volume or files require duplication.
2. Ensure that the virtual tape device is available, that is, varied on.

This can be checked in IBM @server iSeries Navigator by selecting **Configuration and Service** → **Hardware** → **Tape Devices** → **Stand-Alone Devices**. The right window pane should show the tape device as having a status of Available. If it does not show this status, right-click your device and select **Make Available**.

To check on a 5250 emulation screen, enter the following command:

```
WRKDEVD *TAP
```

To get a listing of the tape devices, select option **8** next to the tape device to work with configuration status. The device's status should be Available or Varied on. If it is not, select option **1** to make available or vary on.

3. Ensure the image catalog that contains the volume to be duplicated is loaded on the virtual tape device.

This can be checked in iSeries Navigator by selecting **Configuration and Service** → **Hardware** → **Tape Devices** → **Image Catalogs**. The image catalog in the right panel should show a status of Loaded. If it does not, right-click the image catalog and select **Load Image Catalog**.

From a 5250 emulation screen, use the WRKIMGCLGE command to view the status of the image catalog and the volumes. The image catalog status should be Ready. If not, use the LODIMGCLG command. Refer to “Load the image catalog in the virtual device” on page 56 for more information about loading an image catalog.

4. Ensure that the status of the volume to be duplicated is Loaded or Mounted.

This can be checked in IBM @server iSeries Navigator by selecting **Configuration and Service** → **Hardware** → **Tape Devices** → **Image Catalogs**, and right-clicking the image catalog from the right pane and then selecting **List volumes**.

To display the contents of the volume, right-click the volume and select **Display Volume Labels** or select **Print tape to create a spool file**. Refer to 3.2.3, “Viewing the virtual volumes” on page 67 for more information about viewing the contents.

From a 5250 emulation screen, use the WRKIMGCLGE command to view the status of the volumes. The status of the volume to be duplicated should be Loaded or Mounted.

5. Ensure that the target device's status is Available, that is, Varied on.

This can be checked in IBM @server iSeries Navigator by selecting **Configuration and Service** → **Hardware** → **Tape Devices** → **Stand-Alone Devices**. The right window pane should show your tape device with a status of Available. If it does not, right-click your device and select **Make Available**.

To check on a 5250 emulation screen:

Enter the following command on the command line to get a listing of the tape devices:

```
WRKDEVD *TAP
```

Select option **8** next to your tape device to work with configuration status. The device should have a status of Available or Varied on. If it does not, select option **1** to make available or varied on.

6. Ensure that a tape is loaded or mounted on the target tape device and is in the proper format, whether duplicating to an initialized tape or appending to an existing volume.

### **Proper format (DENSITY)**

The DENSITY format of the target volume (that is, physical volume) must have the equivalent or higher block size than the source volume (that is, virtual tape).

To check the DENSITY of your virtual volume (that is, source volume) through IBM @server iSeries Navigator, select **Configuration and Service** → **Hardware** → **Tape Devices** → **Tape Image Catalogs**. Then right-click the image catalog and select **List Volumes**, as shown in Figure 3-53 on page 92.

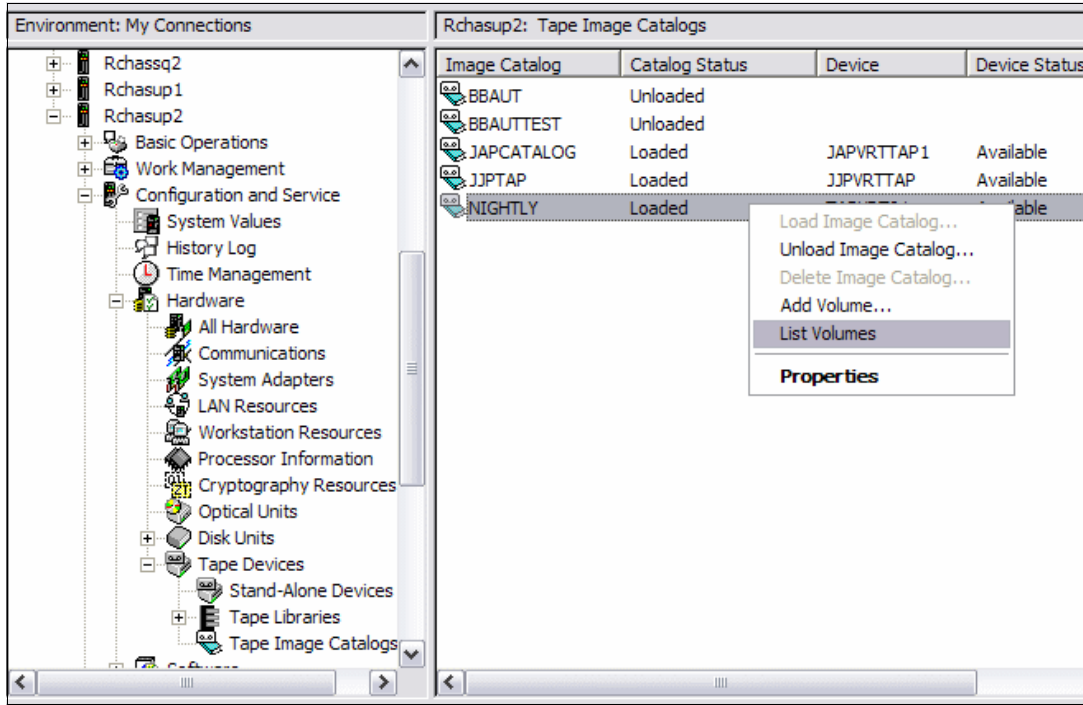

Figure 3-53 List volumes for density through Navigator

The DENSITY will be listed for each virtual volume, which also gives the block size. For example, a density of \*VRT256K has a block size of 256 K, as shown in Figure 3-54.

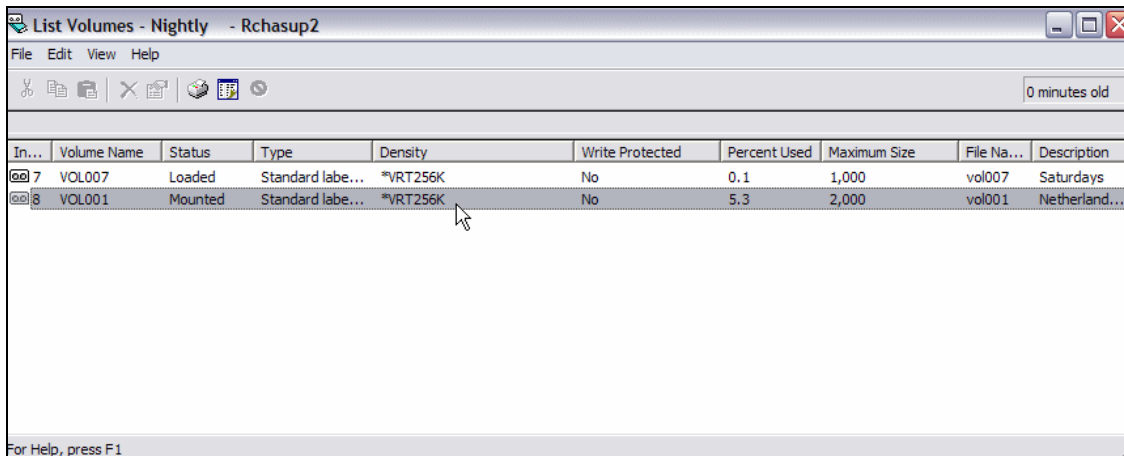

Figure 3-54 Virtual volume density through Navigator

To check the density of your virtual volume through 5250 emulation session, use the Work with Image Catalog Entries (WRKIMGCLGE) command. Figure 3-55 shows a window where the volume has a density of \*VRT256K. Thus, the block size is 256 K.

```

Work with Image Catalog Entries
                                     System:  RCHASUP2
Catalog . . . : NIGHTLY               Status . . . : Ready
Type . . . . : Tape                   Device . . . : TAPVRT01
Directory . . : /images/tape/nightly

Type options, press Enter.
 1=Add  2=Change  4=Remove  6=Mount  8=Load  9=Unload
10=Initialize volume  11=Display  13=Dump  14=Duplicate

Opt  Index  Status      Volume Name  Density      Type  Write
      *AVAIL
      7  Loaded      VOL007      *VRT256K    *SL  No
      8  Mounted     VOL001      *VRT256K    *SL  No

Bottom

F3=Exit  F5=Refresh      F6=Load image catalog  F8=Reorder by index
F11=View size information  F12=Cancel  F22=Display entire field

```

Figure 3-55 Virtual volume density through 5250 emulation

### ***New physical volume density***

If you are duplicating to a new physical volume, initialize the tape to a density that has a block size equal to or larger than the virtual volume (that is, source volume). Refer to Appendix A, “Block sizes” on page 457 to determine your tape drive’s block size capability and supported format densities. If your drive or density is not listed, refer to your tape device operator manual.

To initialize the tape volume through Navigator, **select Configuration and Service → Hardware → Tape Devices → Stand-Alone Devices**. Then right-click the tape drive and select **Format**, as shown in Figure 3-56 on page 94.

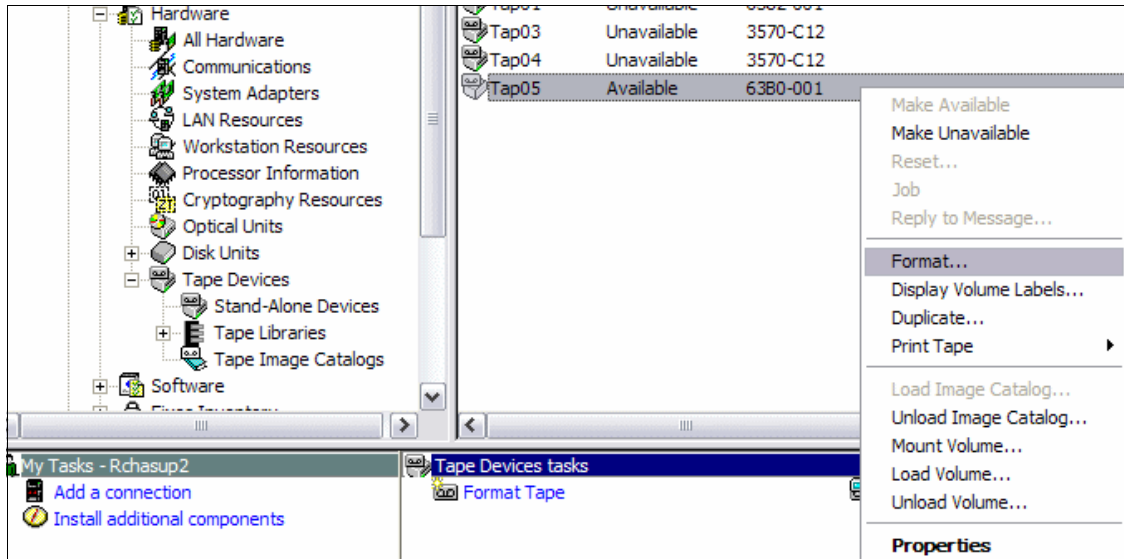

Figure 3-56 Format volume through Navigator

The Format Tape window has a General tab and an Options tab.

The General tab is shown in Figure 3-57.



Figure 3-57 Format volume general tab through Navigator

The General tab has the following parameters:

- ▶ New volume label (NEWVOL): This specifies the volume identifier for a tape being initialized for use as a standard labeled tape. If no volume identifier is specified, the tape is initialized for use as an unlabeled tape.
- ▶ Check for volume (VOL): This specifies the existing volume identifier of the tape being initialized for use or indicates that the tape currently on the magnetic tape unit should be initialized for use.

**Note:** If the device specified is a media library device, or a virtual tape device, the volume specified should be the cartridge identifier or the virtual tape volume name to be mounted and used.

- ▶ Check for active files (CHECK): This specifies whether a labeled tape volume should be checked for active data files before it is initialized for use. If an unlabeled volume is placed in the specified device, this parameter is ignored.
- ▶ End of tape action (ENDOPT): This specifies whether the tape is only rewound, or rewound and unloaded, after the operation ends.

The Options tab has the following parameters, as shown in Figure 3-58.

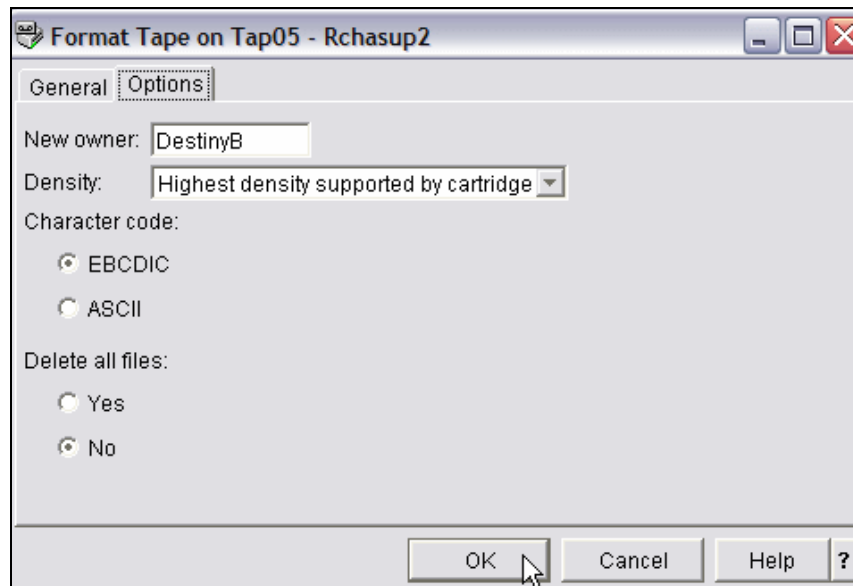

Figure 3-58 Format volume options tab through Navigator

- ▶ New owner (NEWOWNID): This specifies the identifier of the tape owner to write in the volume label.

- ▶ Density (DENSITY): This specifies the recording format of the data to be written on the tape.
  - \*DEVTYPE: The highest capacity density or format supported by the tape device will be used.
  - \*CTGTYPE: The highest capacity density or format supported by the device for the mounted cartridge type will be used. If the device does not support special cartridge type information, \*DEVTYPE is used.
  - character-value: This specifies the density or format to use.
- ▶ Character code (CODE): This specifies the character code in which the volume label is written. All data that is not save data written after the label, must be in the same code. Codes cannot be intermixed on a tape that is not a save tape. If the tape is being initialized for use as an unlabeled tape with \*NONE or no volume identifier specified in the New volume identifier prompt (NEWVOL parameter), this parameter is ignored.
  - \*EBCDIC: The volume label is written in EBCDIC and is an IBM standard label. All additional data must also be written in EBCDIC.
  - \*ASCII: The volume label is written in ASCII and is an ANSI standard label. All additional data must also be written in ASCII.
- ▶ Delete all files (CLEAR): This specifies whether all previous labels and data are deleted from the tape when it is initialized. If the volume must be cleared of all data, it is spaced from the location of the initializing volume label or tape markers to the end of the tape marker.

To format a new volume using a 5250 emulation session, issue the following INZTAP command:

```
INZTAP DEV(TAP05) NEWVOL(DUP001) NEWOWNID(DESTINYB) VOL(DUP001) CHECK(*NO)
DENSITY(*CTGTYPE)
```

Figure 3-59 on page 97 shows the corresponding window.

```

Initialize Tape (INZTAP)

Type choices, press Enter.

Device . . . . . > TAP05      Name
New volume identifier . . . . . DUP001      Character value, *NONE...
New owner identifier . . . . . DestinyB
Volume identifier . . . . . DUP001      Character value, *MOUNTED
Check for active files . . . . . *NO      *YES, *NO, *FIRST
Tape density . . . . . *CTGTYPE      *DEVTYPE, *CTGTYPE, *QIC120...
Code . . . . . *EBCDIC      *EBCDIC, *ASCII
End of tape option . . . . . *REWIND      *REWIND, *UNLOAD
Clear . . . . . *NO      *NO, *YES

Bottom
F3=Exit  F4=Prompt  F5=Refresh  F12=Cancel  F13=How to use this display
F24=More keys

```

Figure 3-59 Initialize tape through 5250 emulation

**Appended volume density**

To check the block size of a physical tape you are appending, **select Configuration and Service → Hardware → Tape Devices → Stand-Alone**

**Devices.** Then right-click the tape drive and select **Display Volume Labels**, as shown in Figure 3-60.

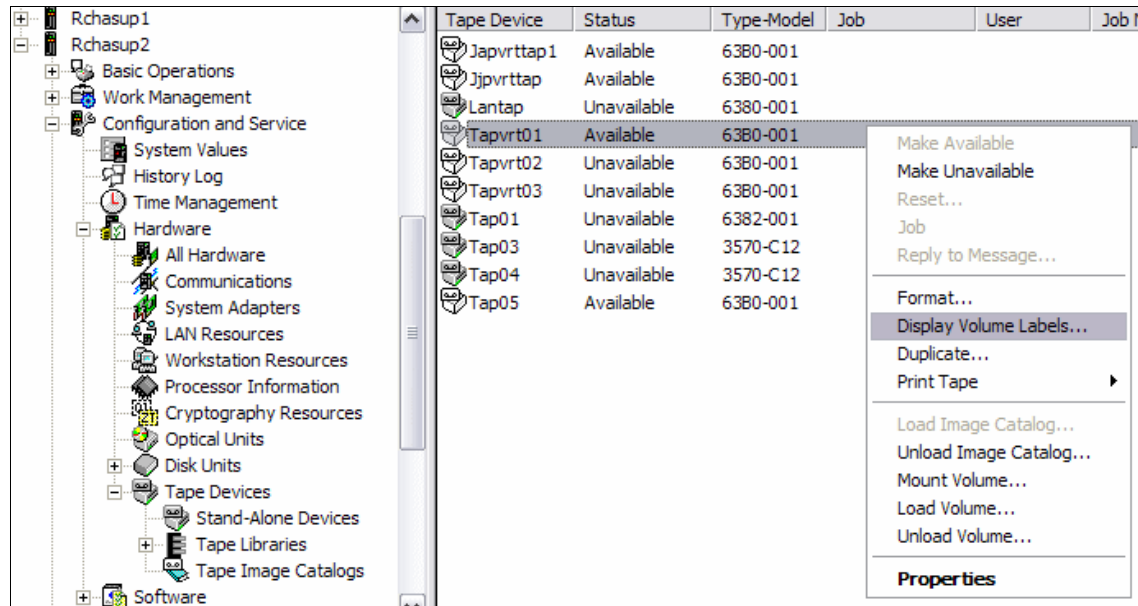

Figure 3-60 Display volume for density through Navigator

This will display the window shown in Figure 3-61 on page 99. After selecting the relevant parameters, click **OK**.

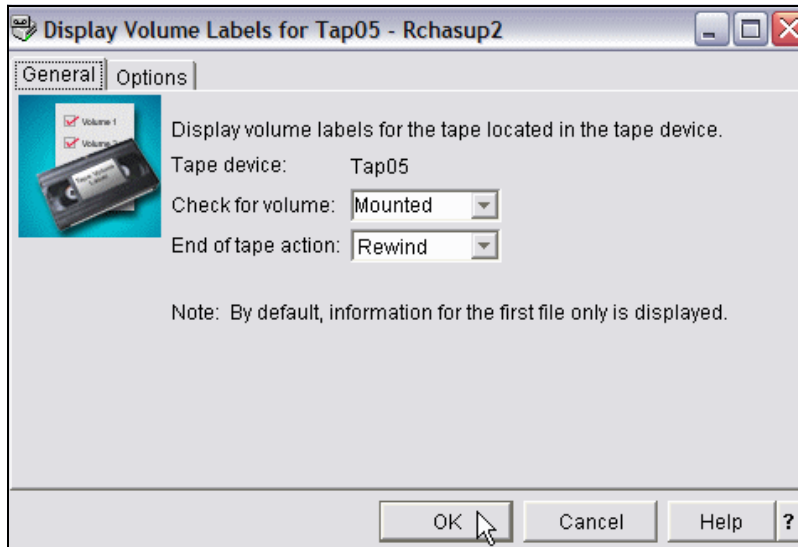

Figure 3-61 Display label for density through Navigator

This displays Figure 3-62 on page 100, where the Density is shown as \*QIC4GB on the top right corner.

Once you know your tape drive or density, refer to Appendix A, “Block sizes” on page 457 to determine its block size. If your drive or density is not listed, refer to your tape device operator manual.



Figure 3-62 Density format of physical tape

To check the density of an existing volume through 5250 emulation session, use the following DSPTAP command:

```
DSPTAP DEV(TAP05) VOL(DUP001) SEQNBR(*FIRST *ONLY)
```

The corresponding 5250 emulation screens are shown in Figure 3-63 on page 101 and Figure 3-64 on page 101.

```

                                Display Tape (DSPTAP)

Type choices, press Enter.

Device . . . . . TAP05           Name
Volume identifier . . . . . DUP001   Character value, *MOUNTED
File label . . . . . *ALL
Sequence number:
  Starting file sequence number *FIRST   1-16777215, *ALL, *FIRST
  Ending file sequence number . *ONLY    1-16777215, *ONLY, *LAST
Data type . . . . . *LABELS        *LABELS, *SAVRST
Output . . . . . *                  *, *PRINT, *OUTFILE
End of tape option . . . . . *REWIND  *REWIND, *UNLOAD

                                                                Bottom
F3=Exit  F4=Prompt  F5=Refresh  F12=Cancel  F13=How to use this display
F24=More keys

```

Figure 3-63 Display sequence through 5250 emulation

```

                                Display Tape Volume Information

Device . . . . . : TAP05           Volume ID . . . . . : DUP001
Owner ID . . . . . : Dino          Density . . . . . : *FMT3590E
Type . . . . . : *SL              Code . . . . . : *EBCDIC

Data file label . . . . . : DESTINY
File sequence . . . . . : 0000000001

Record format . . . . . : U
Block attribute . . . . . :
Record length . . . . . : 00000
Block length . . . . . : 032760
File length . . . . . : 0000000414
Buffer offset . . . . . :
Control character . . . . . :

                                                                More...

Press Enter to continue.

F3=Exit  F12=Cancel
(C) COPYRIGHT IBM CORP. 1980, 2005.

```

Figure 3-64 Display volume for density through 5250 emulation

### 3.3.2 Duplicating virtual tape to physical tape

Duplicating virtual tape to physical tape allows the physical tape to be utilized just as if the backup had been initially saved to the physical media.

The process involved in duplicating virtual tape to physical tape is essentially the same as duplicating from one physical tape to another.

If you are using IBM @server iSeries Navigator to duplicate an exact copy of a virtual volume to a physical tape, select **Configuration and Service** → **Hardware** → **Tape Devices** → **Tape Devices** → **Tape Image Catalogs**. Then right-click the image catalog, select **List Volumes** and right-click the volume and select **Duplicate**, as shown in Figure 3-65.

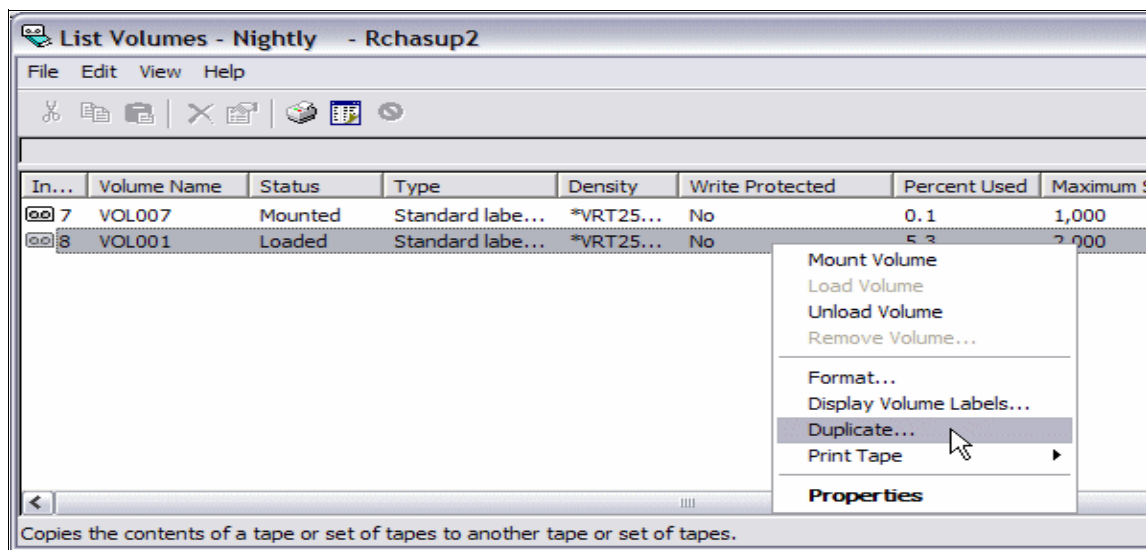

Figure 3-65 Duplicate volume through Navigator

This displays a window containing the General tab, the Files tab, and the Options tab. When you click the General tab, the window shown in Figure 3-66 appears.

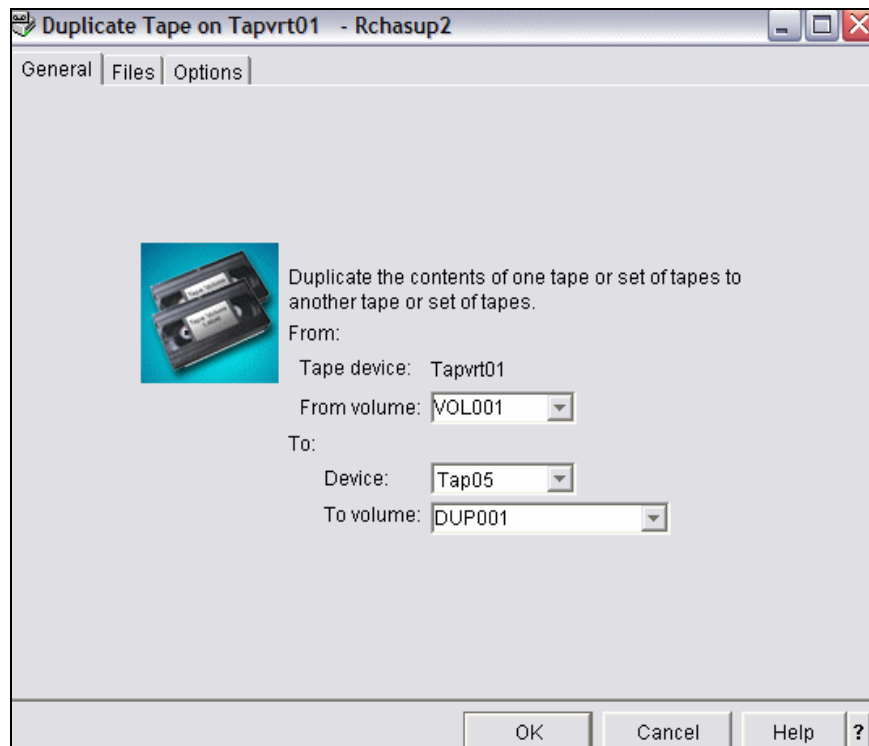

Figure 3-66 Duplicate volume general tab through Navigator

The following parameters can be set in the General tab:

- ▶ From device (FROMDEV): This specifies the device from which the tape is copied. This is a required parameter.  
name: This specifies the name of the tape device where the tape to be copied is mounted.
- ▶ From volume (FROMVOL): This specifies the volume identifier of the tape being duplicated.
  - \*MOUNTED: Any labeled or unlabeled volume placed on the tape device specified in the From device (FROMDEV) parameter is duplicated.  
For a tape media library device, the volume to be used is the next cartridge in the category mounted by the Set Tape Category (SETTAPCGY) command.

For a virtual tape device, the volume to be used is the currently mounted one. If there is no currently mounted volume, the next volume in the loaded status in the image catalog should be used.

**Note:** If the device specified is a media library device or a virtual tape device, the volume specified should be the cartridge identifier or virtual tape volume name to be mounted and used.

character-value: This specifies the identifier of the labeled volume being duplicated.

- ▶ To device (TODEV): This specifies the device to which the tape is copied. This is a required parameter.

name: This specifies the name of the tape device where the tape volume to which data is being copied is mounted.

- ▶ To volume (TOVOL): This specifies the volume identifiers of the tapes to which data is being copied.
  - \*MOUNTED: The volume currently placed in the device is used. For a media library device, the volume to be used is the next cartridge in the category mounted by the Set Tape Category (SETTAPCGY) command. For a virtual tape device, the volume to be used is the currently mounted one. If there is no currently mounted volume, then the next volume in loaded status in the image catalog should be used.

**Note:** If the device specified is a media library device or a virtual tape device, the volume specified should be the cartridge identifier or virtual tape volume name to be mounted and used.

- \*FROMVOL: The volume label of the tape placed in the device specified on the From device (FROMDEV) parameter is used to initialize the tape placed in the device specified on the To device (TODEV) parameter. Up to eight additional volume labels and nine user volume labels are duplicated. This value is not supported for tape media library devices and virtual tape devices.

character-value: This specifies the volume identifier of the tapes to which data is being copied. At the end of volume time, you can reinitialize the tape using this volume identifier. If the volume contains the correct volume identifier, but is in the wrong code or density, the tape is reinitialized to the correct code and density. The volume identifier is saved.

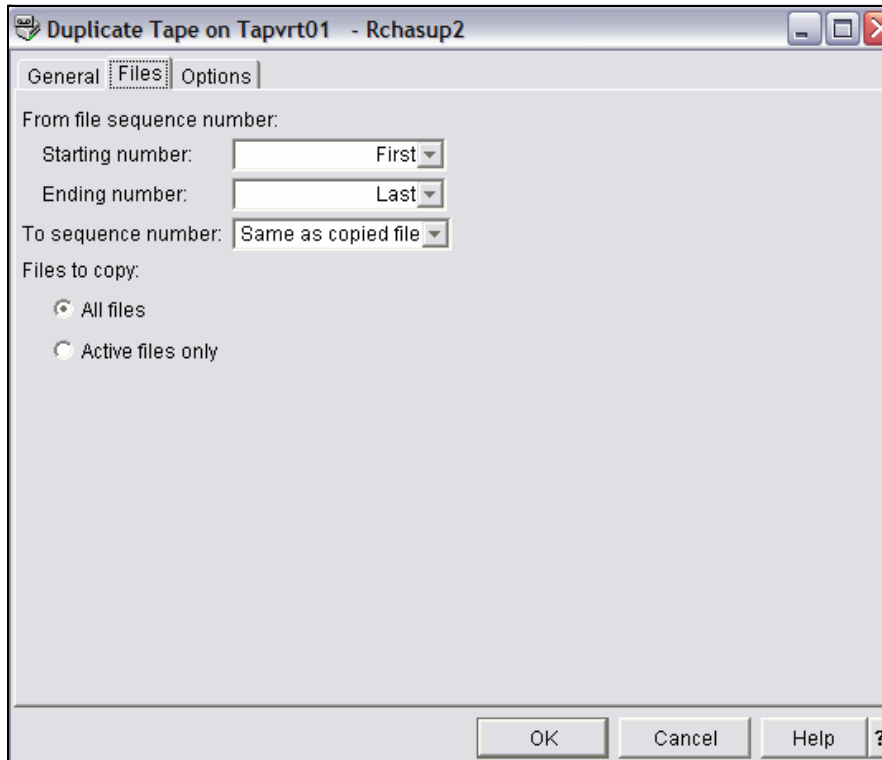

Figure 3-67 Duplicate volume files tab through Navigator

The following parameters can be set in the Files tab shown in Figure 3-67:

- ▶ Starting sequence number (STRSEQNBR): This specifies which data file sequence numbers are to be copied.
  - \*ALL: All files are duplicated.
  - \*FIRST: All files starting with the first file sequence are duplicated.
  - 1-16777215: This specifies the starting file sequence number to be duplicated. Only the files in the specified sequence number range are duplicated.
- ▶ Ending sequence number (ENDSEQNBR): This specifies which data file sequence numbers are to be copied.
  - \*LAST: All files ending with the last file sequence are duplicated.
  - \*ONLY: Only the file specified in the starting file sequence is duplicated.
  - 1-16777215: This specifies the ending file sequence number of the range to be duplicated.

- ▶ To sequence number (TOSEQNBR): This specifies which sequence number the data files are to be copied to.
  - \*FROMSEQ: The data files are duplicated to the same file sequences as are specified in the from-file sequence number parameter.
  - \*END: The data files are added to the logical end of tape. The next valid sequence number is used.
  - 1-16777215: This specifies the sequence number in which the data file will be copied to. This value is not allowed if the device does not have overwriting capabilities and the value specified is not the next logical value to be used at the end of the logical tape volume. The duplication begins in the specified file.
- ▶ Files to copy (FILES): This specifies whether the expired data files are copied from the tape volume placed in the device specified in the From device (FROMDEV) parameter, to the tape volume placed on the device specified in the To device (TODEV) parameter.
  - \*ALL: All data files on the tape volume are copied. All existing file sequence numbers are saved.
  - \*ACTIVE: Only data files with an expiry date later than the current system date are copied. Data files are renumbered consecutively, beginning with the number of the other first file on the volume and omitting any files that have expired.

The Options tab is shown in Figure 3-68 on page 107.

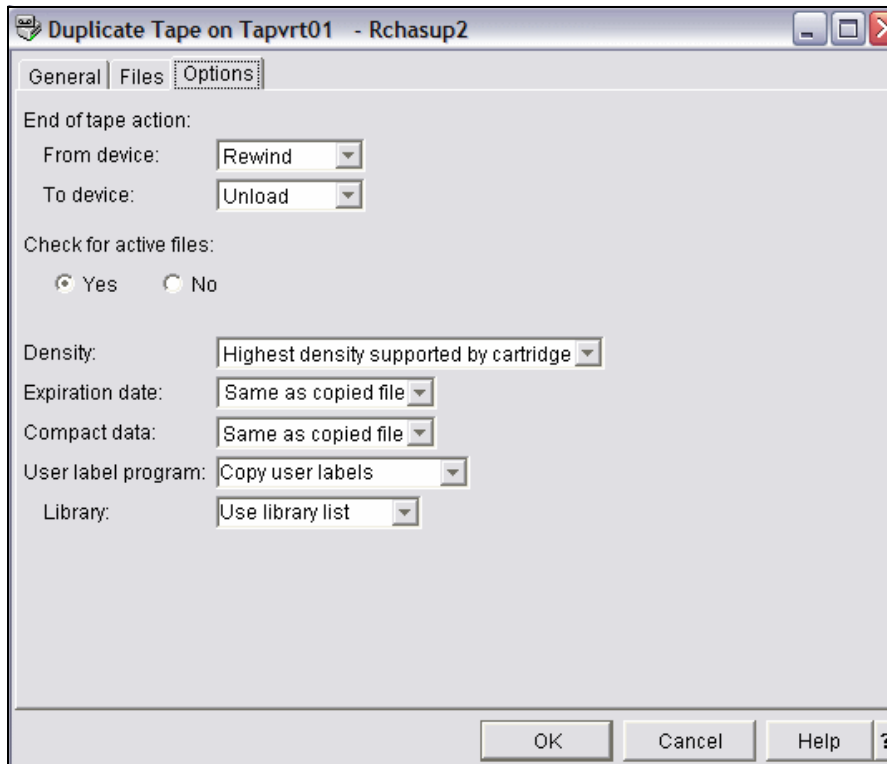

Figure 3-68 Duplicate volume options through Navigator

The Options tab contains the following parameters:

- ▶ From device end action (FROMENDOPT): This specifies whether the tape volume placed on the device specified in the From device (FROMDEV) parameter is rewind, or rewind and unloaded, after the operation is completed.
  - \*REWIND: The tape is automatically rewind, but not unloaded, after the operation has ended.
  - \*UNLOAD: The tape is automatically rewind and unloaded after the operation ends.
  - \*LEAVE: The tape does not rewind or unload after the operation ends. It remains at the current position on the tape drive.

- ▶ To device end action (TOENDOPT): This specifies whether the tape volume placed on the device specified in the To device (TODEV) parameter is rewound, or rewound and unloaded, after the operation is completed.
  - \*UNLOAD: The tape is rewound and unloaded after the operation is completed.
  - \*REWIND: The tape is rewound, but not unloaded.
  - \*LEAVE: The tape does not rewind or unload after the operation ends. It remains at the current position on the tape drive.
- ▶ Check for active files (CHECK): This specifies whether a tape file on the volume mounted on the To device (TODEV) parameter is checked for active data before it is overwritten. If an unlabeled volume is on the To device, this parameter is ignored.
  - \*YES: The file to be overwritten is checked for active data. Only the first file to be overwritten is checked for active data. Any subsequent files are not checked. If active files are found, the operation is ended and an error message is sent.
  - \*NO: Tape duplication continues, with no checking for active files.
- ▶ Density (DENSITY): This specifies the density or format in which the copied data is written.
  - \*DEVTYPE: The highest capacity density or format supported by the tape device will be used.
  - \*CTGTYPE: The highest capacity density or format supported by the device for the mounted cartridge type will be used. If the device does not support special cartridge type information, \*DEVTYPE is used.
  - character-value: This specifies the density or format to use.
- ▶ Expiration date (EXPDATE): This specifies the expiration date to be assigned to all the files when they are copied. This parameter only applies to standard labeled tapes.
  - \*FROMFILE: The expiration date currently specified for the file to be copied is used.
  - \*PERM: All the copied files will be assigned a permanent expiration date.
  - date: This specifies the expiration date to be assigned to all the files when they are copied.

- ▶ Compact data (COMPACT): This specifies whether device data compaction is performed. If the device specified does not support compaction, this parameter is ignored.
  - \*FROMFILE: Device data compaction is performed only if the file being read from the device specified in the From device (FROMDEV) parameter was written using device data compaction.
  - \*YES: Device data compaction is performed on all files written to the device specified in the To device (TODEV) parameter.
  - \*NO: Device data compaction is not performed.
- ▶ User label program and library (USRLBLPGM): This specifies the name and library of the user program that processes user tape labels. For the device specified in the To device (TODEV) parameter, the user label program sends the user labels that are written to tape. For the device specified in the From device (FROMDEV) parameter, the user labels are sent to the user label program.
  - \*SYSCOPY: User tape labels are processed to allow proper duplication of System/36™ save and restore tapes. If user header labels are present on the tape volume specified in the FROMDEV parameter, they are copied to the tape volume specified in the TODEV parameter. The same is done for the user trailer labels at the end of the file or for the trailer labels at the end of the file section.
 

If an end-of-volume condition occurs on the device specified in the TODEV parameter before logical end-of-tape is found on the device specified in the FROMDEV parameter, user trailer and user header labels are created and written to the current and next tape volumes that replicate the data from the user header label read at the beginning of the file.
  - \*NONE: No user program processes user tape labels. No user labels are written to the tape volume.
 

Qualifier 1: User label program.

    - name: This specifies the name of the user program that processes the user tape labels.

Qualifier 2: Library

    - \*LIBL: All libraries in the library list for the current thread are searched until the first match is found.
    - \*CURLIB: The current library for the job is used to locate the user label program. If no library is specified as the current library for the job, QGPL is used.
    - name: This specifies the name of the library where the user label program is located.

The duplication tasks are complete. The target volume DUP001 on the physical drive should now be a copy of the source volume VOL001 on the virtual drive.

If you are on a 5250 emulation session and wish to duplicate your media, use the DUPTAP command. If the tape duplication from IBM @server iSeries Navigator was performed using a command, the following command should be entered:

```
DUPTAP FROMDEV(TAPVRT01) TODEV(TAP05) FROMVOL(VOL001) TOVOL(DUP001)
TODENSITY(*CTGTYPE)
```

Figure 3-69 shows the corresponding window.

```

                                Duplicate Tape (DUPTAP)

Type choices, press Enter.

From device . . . . . > TAPVRT01      Name
To device . . . . . > TAP05          Name
From sequence number:
  Starting file sequence number  *FIRST      1-16777215, *ALL, *FIRST
  Ending file sequence number    *LAST      1-16777215, *ONLY, *LAST
To sequence number . . . . . *FROMSEQ    1-16777215, *END, *FROMSEQ

                                Additional Parameters

From volume identifier . . . . . > VOL001      Character value, *MOUNTED
      + for more values
To volume identifier . . . . . > DUP001      Character value, *MOUNTED...
      + for more values
Tape density . . . . . > *CTGTYPE          *DEVTYPE, *CTGTYPE, *QIC120...

                                                                Bottom
F3=Exit  F4=Prompt  F5=Refresh  F10=Additional parameters  F12=Cancel
F13=How to use this display  F24=More keys
```

Figure 3-69 Duplicate volume through 5250 emulation

### Copying specific objects

Although it is more common to copy the entire virtual tape to physical tape, there are times when you may want to copy only parts of the virtual backup to physical tape. Selecting specific objects to be copied directly from a virtual volume to a physical volume cannot be performed by using the Duplicate (DUPTAP) function. However, it is possible to copy portions of the volume duplicating specific sequence numbers of the volume.

Rather than duplicating a specific object, duplicate all the objects of a specific sequence. Sequences are written to tape for every Save operation performed to tape. For example, if you perform a SAVLIB of a specific library to tape, that library and all of its objects will be under one sequence. If the SAVLIB is for a special value such as \*ALLUSR, all the libraries will be contained under one sequence. You cannot use the Duplicate (DUPTAP) function to copy specific objects out of each sequence directly to tape. If a SAVLIB LIB(\*ALLUSR) is performed and is saved under one sequence, you will have to duplicate the entire sequence. You cannot duplicate only one library directly to another tape volume.

Duplication of specific sequences is performed by specifying a Starting sequence number (STRSEQNBR) and an Ending sequence number (ENDSEQNBR). These parameters are found in the Files tab of the Duplicate function in IBM @server iSeries Navigator. Figure 3-70 shows the Files tab after selecting a volume to duplicate.

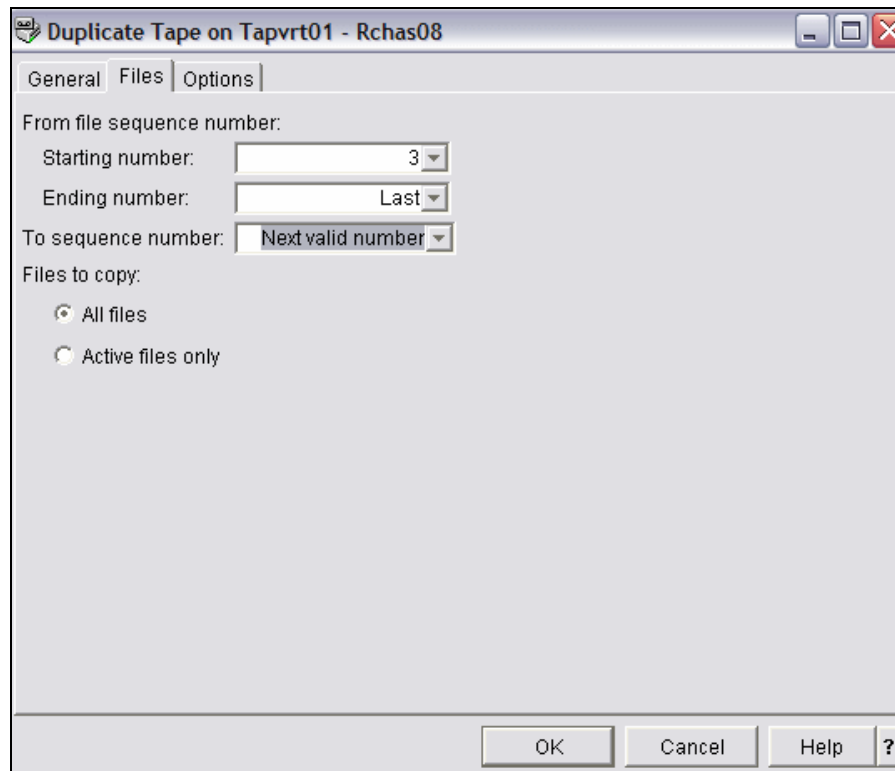

Figure 3-70 Duplicate sequence through Navigator

From the example provided, sequence 3 through the last sequence of the source tape will be appended to the next sequence available on the target tape where the data is being duplicated.

If using a 5250 emulation, the STRSEQNBR and ENDSEQNBR parameters are seen on the first screen when the DUPTAP command is used. Figure 3-71 shows a volume on TAPVRT01, where the third sequence through the last sequence is being appended to the next sequence available on the target tape where the data is being duplicated.

```

                                Duplicate Tape (DUPTAP)

Type choices, press Enter.

From device . . . . . TAPVRT01      Name
To device . . . . . TAP05          Name
From sequence number:
  Starting file sequence number  3      1-16777215, *ALL, *FIRST
  Ending file sequence number . *LAST   1-16777215, *ONLY, *LAST
To sequence number . . . . . *END     1-16777215, *END, *FROMSEQ

                                                                 Bottom
F3=Exit  F4=Prompt  F5=Refresh  F10=Additional parameters  F12=Cancel
F13=How to use this display  F24=More keys

```

Figure 3-71 Duplicate sequence through 5250 emulation

### 3.3.3 Saving virtual tape as an object

This section shows how to save the entire virtual tape volume as a STMF that can later be restored to a system, while retaining its virtual volume characteristics.

**Note:** Objects cannot be directly restored from the physical tape if the virtual volume is saved to the tape as a STMF object rather than as a duplication to a tape. To restore objects directly from tape, refer to 3.3.2, “Duplicating virtual tape to physical tape” on page 102.

## Saving image objects

Virtual tape volumes can be saved to physical media while still retaining their virtual volume characteristics. This is obtained by saving the STMF object that resides in the IFS. The virtual volume stream file resides in the directory of the image catalog. The object in the directory is the name of the image file name, and not the volume name.

To access the directory, select **Configuration and Service** → **Hardware** → **Tape Devices**. Then right-click **Tape Image Catalogs** and click **Properties**. The Properties window shows the location of the image catalog. Figure 3-72 shows an example of the image catalog (Nightly), which is pointed to the location /images/tape/nightly.

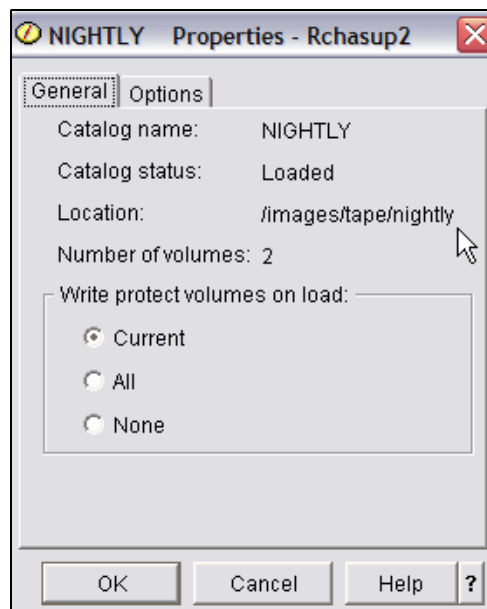
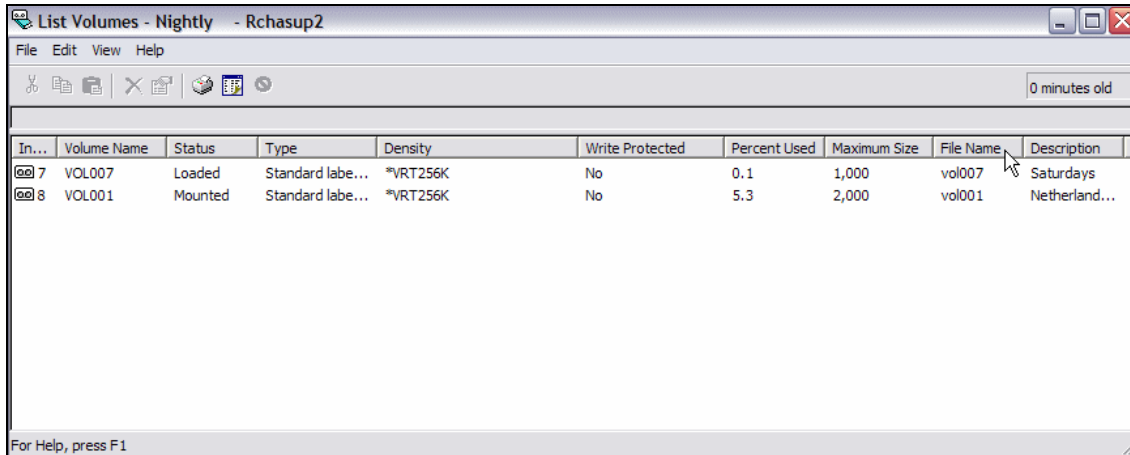

Figure 3-72 Image catalog directory through Navigator

To file the image file name, select **Configuration and Service** → **Hardware** → **Tape Devices**. Then right-click **Tape Image Catalogs** and click **List Volumes**, which shows the volume and contains a field listing the file name.

Figure 3-73 shows volume VOL001, which also has the same name, VO001, for the image file.



The screenshot shows a window titled "List Volumes - Nightly - Rchasup2". The window contains a table with the following columns: In..., Volume Name, Status, Type, Density, Write Protected, Percent Used, Maximum Size, File Name, and Description. The table lists two volumes: VOL007 and VOL001. A mouse cursor is pointing to the "File Name" column for VOL001, which contains the value "vol001".

In...	Volume Name	Status	Type	Density	Write Protected	Percent Used	Maximum Size	File Name	Description
7	VOL007	Loaded	Standard labe...	*VRT256K	No	0.1	1,000	vol007	Saturdays
8	VOL001	Mounted	Standard labe...	*VRT256K	No	5.3	2,000	vol001	Netherland...

Figure 3-73 Volume file name through Navigator

**Note:** The image file name can differ from the volume name.

To find the image catalog directory through 5250 emulation, work with the image catalog entry WRKIMGCLGE for the image catalog and you will see the directory in the upper left corner as shown in Figure 3-74 on page 115.

```

Work with Image Catalog Entries
System: RCHITSO
Catalog . . . : NIGHTLY      Status . . . : Ready
Type . . . . : Tape         Device . . . : TAPVRT01
Directory . . : /images/tape/nightly

Type options, press Enter.
1=Add  2=Change  4=Remove  6=Mount  8=Load  9=Unload
10=Initialize volume  11=Display  13=Dump  14=Duplicate

Opt  Index  Status      Volume Name  Density      Type  Write
      *AVAIL
      7  Loaded      VOL007      *VRT256K    *SL  No
      8  Mounted      VOL001      *VRT256K    *SL  No

Bottom
F3=Exit  F5=Refresh      F6=Load image catalog  F8=Reorder by index
F11=View size information  F12=Cancel  F22=Display entire field

```

Figure 3-74 Image catalog directory through 5250 emulation

To find the image file name for the volume, press F11 three times. This displays the screen shown in Figure 3-75 on page 116.

```

                                Work with Image Catalog Entries
                                System:  RCHITSO
Catalog . . . : NIGHTLY           Status . . . : Ready
Type . . . . : Tape              Device . . . : TAPVRT01
Directory . . : /images/tape/nightly

Type options, press Enter.
 1=Add  2=Change  4=Remove  6=Mount  8=Load  9=Unload
10=Initialize volume  11=Display  13=Dump  14=Duplicate

Opt  Index  Status      Image File Name
   *AVAIL
     7  Loaded   vol007
     8  Mounted  vol001

                                Bottom
F3=Exit  F5=Refresh      F6=Load image catalog  F8=Reorder by index
F11=View volume information  F12=Cancel  F22=Display entire field

```

Figure 3-75 Volume file name through 5250 emulation

### **SAV the image file**

The image catalog directory contains the location of your virtual images. To save the images, use the SAV command. Issue the Run Command from the IBM @server iSeries Navigator by right-clicking your system and selecting the Run Command, or enter the SAV command in a 5250 emulation session.

**Note:** A Tape Image File *cannot* be saved if it is loaded in an image catalog with a status of Available or Ready status. This is because an image catalog with Available or Ready status has its \*ALWSAV attribute (in the CHGATR command) set to \*N0. For more information about CHGATR, refer to the Note on CHGATR on page 12.

Figure 3-76 on page 117 shows an example of saving a VOL001 image file to tape using the following command:

```
SAV DEV('/QSYS.LIB/TAP05.DEVD') OBJ((' /images/tape/nightly/vol001'))
```

```

                                Save Object (SAV)

Type choices, press Enter.

Device . . . . . > '/QSYS.LIB/TAP05.DEVD'

                                + for more values

Objects:
  Name . . . . . > '/images/tape/nightly/Vol001'

  Include or omit . . . . . *INCLUDE      *INCLUDE, *OMIT
                                + for more values
Name pattern:
  Pattern . . . . . '*'

  Include or omit . . . . . *INCLUDE      *INCLUDE, *OMIT
                                + for more values
Directory subtree . . . . . *ALL          *ALL, *DIR, *NONE, *OBJ, *STG
Save active . . . . . *NO              *NO, *YES, *SYNC

                                                                More...
F3=Exit  F4=Prompt  F5=Refresh  F10=Additional parameters  F12=Cancel
F13=How to use this display  F24=More keys

```

Figure 3-76 SAV image file through 5250 emulation

To save all your virtual volumes in the image catalog, issue the same command, but for the directory. The Include parameter is set to `*INCLUDE`, which will save all the objects in that directory. However, this saves all the objects in that directory even if they are not an index in the image catalog.

To save the *entire* image catalog directory, enter the following command:

```
SAV DEV('/QSYS.LIB/TAP05.DEVD') OBJ('/images/tape/nightly')
```

Figure 3-77 on page 118 shows the corresponding window.

```

                                Save Object (SAV)

Type choices, press Enter.

Device . . . . . > '/QSYS.LIB/TAP05.DEVD'

                                + for more values

Objects:
  Name . . . . . > '/images/tape/nightly'

  Include or omit . . . . . *INCLUDE      *INCLUDE, *OMIT
                                + for more values
Name pattern:
  Pattern . . . . . '*'

  Include or omit . . . . . *INCLUDE      *INCLUDE, *OMIT
                                + for more values
Directory subtree . . . . . *ALL          *ALL, *DIR, *NONE, *OBJ, *STG
Save active . . . . . *NO                *NO, *YES, *SYNC

                                                                More...
F3=Exit  F4=Prompt  F5=Refresh  F10=Additional parameters  F12=Cancel
F13=How to use this display  F24=More keys

```

Figure 3-77 SAV image catalog directory through 5250 emulation

### Saving image catalog object

If you are saving your tape file images, you may want to consider saving your image catalog object so that you do not need to create the image catalog again or add your virtual images again. The image catalog object is the name of the image catalog and is a type \*IMGLCG. The object resides in the library QUSRSYS. This object can be saved using the SAVOBJ command, or it will get saved when the QUSRSYS library is saved.

To save of an image catalog called Nightly, enter the following command:

```
SAVOBJ OBJ(NIGHTLY) LIB(QUSRSYS) DEV(TAP05) OBJTYPE(*IMGLCG)
```

Figure 3-78 on page 119 shows the corresponding window.

```

                                Save Object (SAVOBJ)

Type choices, press Enter.

Objects . . . . . Nightly      Name, generic*, *ALL
      + for more values
Library . . . . . QUSRSYS     Name, generic*, *USRSPC
      + for more values
Device . . . . . TAP05       Name, *SAVF, *MEDDFN
      + for more values
Object types . . . . . *IMGCLG  *ALL, *ALRTBL, *BNDDIR...
      + for more values

                                                                    Bottom
F3=Exit  F4=Prompt  F5=Refresh  F10=Additional parameters  F12=Cancel
F13=How to use this display  F24=More keys

```

Figure 3-78 Save image catalog object through 5250 emulation

### Transporting virtual storage

Your virtual tape storage is made up of an image catalog object of type \*IMGCLG and its images of type \*STMF in the integrated file system. It is possible to send these objects to another system.

Virtual storage can be transported to another system by one of the following methods:

- ▶ IBM @server iSeries Navigator
- ▶ FTP
- ▶ QFilesvr.400
- ▶ OptiConnect
- ▶ ObjectConnect
- ▶ Save/Restore using physical media
- ▶ NetServer™ shares

For more information about these transportation methods, refer to the IBM knowledge base document No. 30852541, which is available on the Web at:

[http://www-912.ibm.com/s\\_dir/slkbase.NSF/1ac66549a21402188625680b0002037e/cbab7cb7ff94819986256d470075fbc3?OpenDocument](http://www-912.ibm.com/s_dir/slkbase.NSF/1ac66549a21402188625680b0002037e/cbab7cb7ff94819986256d470075fbc3?OpenDocument)

Alternatively, you can visit the IBM @server iSeries Information Center, which is available on the Web at:

<http://publib.boulder.ibm.com/pubs/html/as400/infocenter.html>

## 3.4 Catalog shadowing

This section explains the concept of catalog shadowing, creating dependent catalogs for catalog shadowing, different ways of utilizing the catalogs after shadowing is set up, and ending catalog shadowing by deleting the dependent image catalogs.

### 3.4.1 Overview of catalog shadowing

In this section we define what catalog shadowing is, identify the benefits it offers, review the terms involved in catalog shadowing, and list the characteristics of reference and dependent catalogs.

*Catalog shadowing* is a method used to share a single image or multiple virtual images by using more than one virtual device. This is made possible by creating a “snapshot” of the original image catalog. Figure 3-79 on page 121 illustrates catalog shadowing.

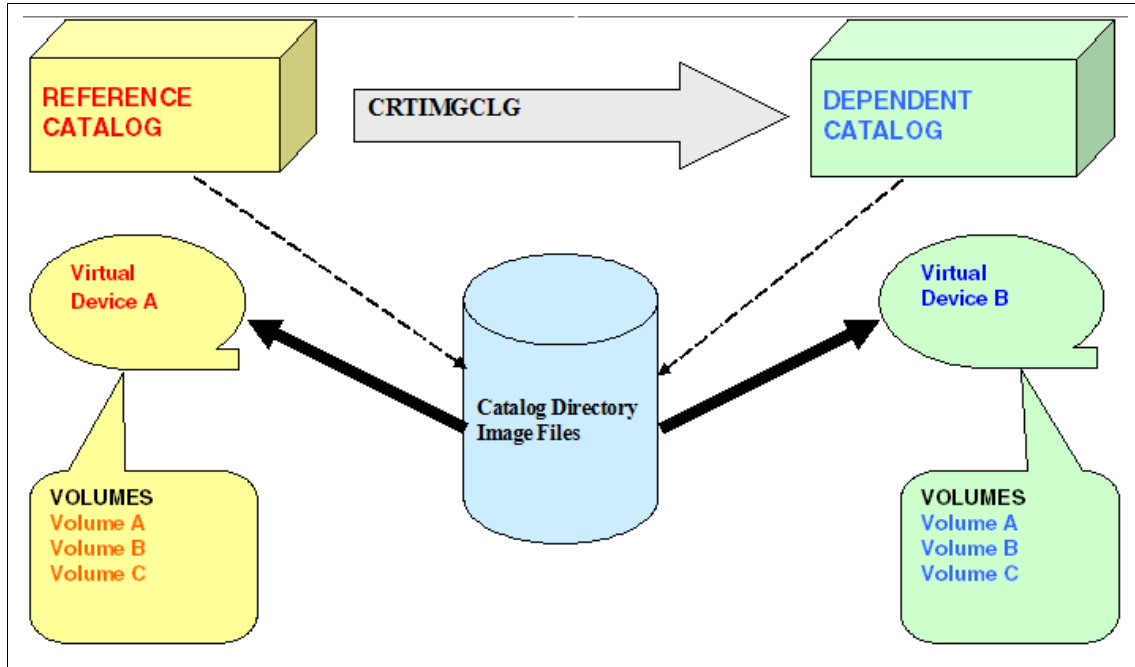

Figure 3-79 Catalog shadowing diagram

### Benefits of catalog shadowing

Catalog shadowing offers the following benefits:

- ▶ It allows more than one operation to be performed on an image catalog or even a single volume. This includes displaying, restoring, installing, and duplicating.
- ▶ It helps to protect against accidental deletion of data. This is because all the volumes in a dependent catalog are write protected. There are other security features such as restricting the deletion or initialization of the original volume.
- ▶ It helps to reduce the amount of system disk space needed to perform some concurrent operations. This is because multiple true bit-for-bit copies are not needed to perform more than one operation on a catalog or a single volume.
- ▶ It can be used to provide an unaltered view of the original image catalog. This is because a dependent catalog is created as a copy of the reference catalog at a single point in time.
- ▶ It can be used to only allow users access to specific volumes within an image catalog.

## Catalog shadowing terms

Two new terms are introduced with catalog shadowing:

▶ Reference catalog

A *reference catalog* is an image catalog that shares its resources (such as catalog information, directory, and image files) with other image catalogs known as *dependent catalogs*. In catalog shadowing, it is the reference catalog, and not the dependent catalog, that actually contains the image files.

▶ Dependent catalog

A *dependent catalog* is an image catalog that is dependent on the resources such as catalog information, directory, and image files, of another image catalog called a reference catalog.

A reference catalog has the following characteristics:

- ▶ An object type of \*IMGCLG.
- ▶ The original image catalog becomes a reference catalog when a dependent catalog is created.
- ▶ The reference catalog contains the actual image files.
- ▶ A reference catalog's image files cannot be removed until all dependent catalogs have been deleted.
- ▶ A reference catalog cannot be deleted until all dependent catalogs have been deleted.
- ▶ Tape reference catalog image files can be loaded in a virtual device as writable or read-only.
- ▶ Optical reference catalog image files can only be loaded in a virtual device as read-only.

A dependent catalog has the following characteristics:

- ▶ An object type of \*IMGCLG.
- ▶ It references a non-dependent catalog's resources.
- ▶ It is loaded as read-only (write protected).
- ▶ It does not set the ALWSAV (allow save) attribute in CHGATR for IFS files.
- ▶ It cannot delete the image files, including the actual ones belonging to the reference catalog with RMVIMGCLGE, WRKIMGCLGE, or DLTIMGCLG commands.
- ▶ It contains a snapshot of the reference catalog during the point when the dependent catalog was created.
- ▶ A dependent catalog does *not* see any new reference catalog volumes that are added after the dependent catalog is created.
- ▶ It does not support the installation of licensed internal code, operating systems, or PTFs.
- ▶ It supports the install of licensed program products (LPPs) if residing in a system ASP or independent ASP.

Figure 3-80 shows a reference catalog and its dependent catalog. The dependent catalog is a “snapshot” of the reference catalog from the time of the dependent catalog’s creation. As can be seen in the figure, both image catalogs can see the volumes. However, they utilize two separate virtual tape devices to view these volumes.

The reference catalog is loaded on virtual device “A, and the dependent catalog is loaded on virtual device B. You can also see that there is only one set of image files that reside in a directory which both catalogs are able to reference.

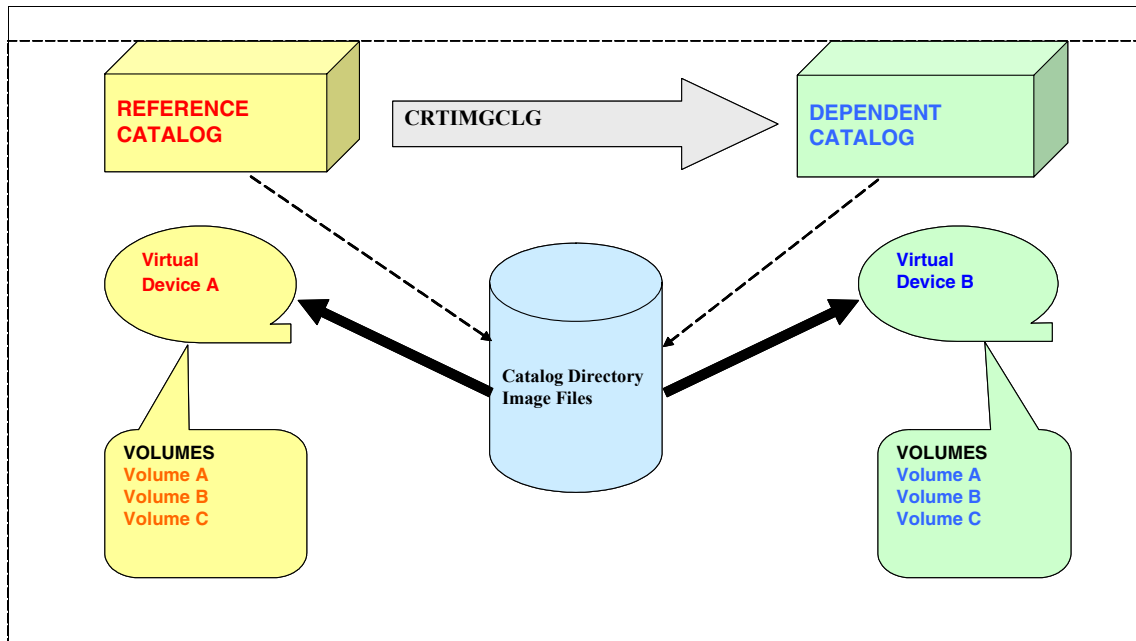

Figure 3-80 Catalog shadowing diagram

Because the dependent is only a snapshot of the reference catalog, it can only view the volumes that existed in the reference catalog during the time of the dependent catalog’s creation. This means that volumes A, B, and C are visible to the dependent catalog because these three volumes existed in the reference catalog during the time of the dependent catalog’s creation.

However, if volume D was added to the reference catalog, the dependent catalog will not be able to see that volume because dependent catalogs are only a snapshot of the reference catalog and dependent catalogs do not get updated. This is illustrated in Figure 3-81 on page 124.

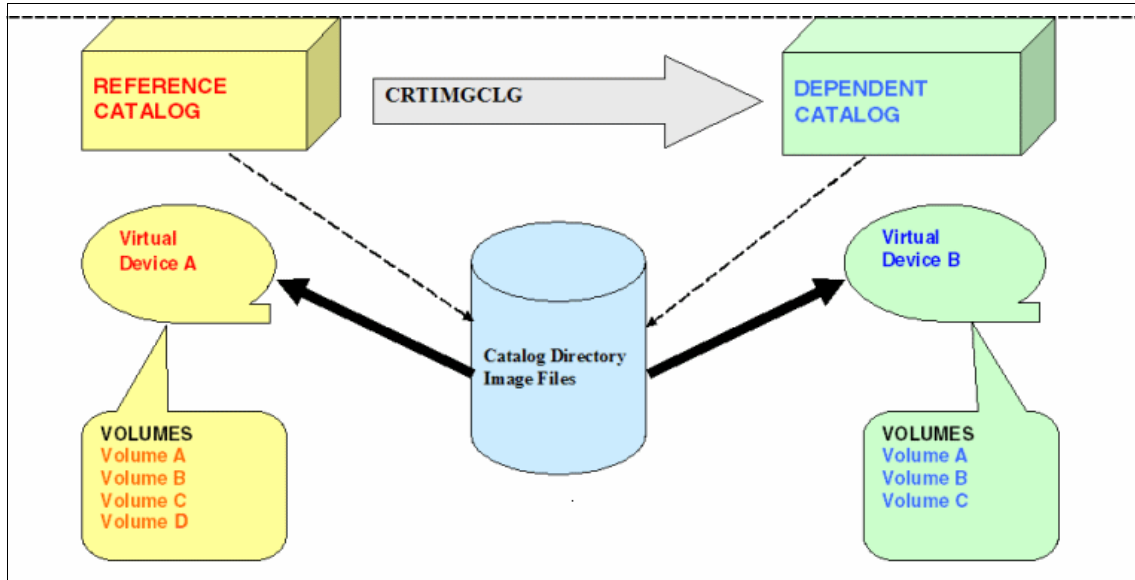

Figure 3-81 Volume added after dependent catalog creation

### 3.4.2 Setting up image catalog shadowing

This section explains how to set up catalog shadowing by creating dependent catalogs.

#### Creating tape type dependent catalogs

Use these steps and commands to create dependent catalogs, which automatically sets up catalog shadowing.

After your tape image catalog is set up and contains all the volumes, make sure that the image catalog status is Unloaded in order to create a dependent catalog.

Verify whether your image catalog status is Unloaded by selecting **Configuration and Service** → **Hardware** → **Tape Devices** → **Tape Image Catalogs**. Your image catalog status should be Unloaded. If it is not, right-click the image catalog and select **Unload Image Catalog**.

Figure 3-82 on page 125 shows the status of the image catalog and illustrates how to change the status to Unloaded and unload it.

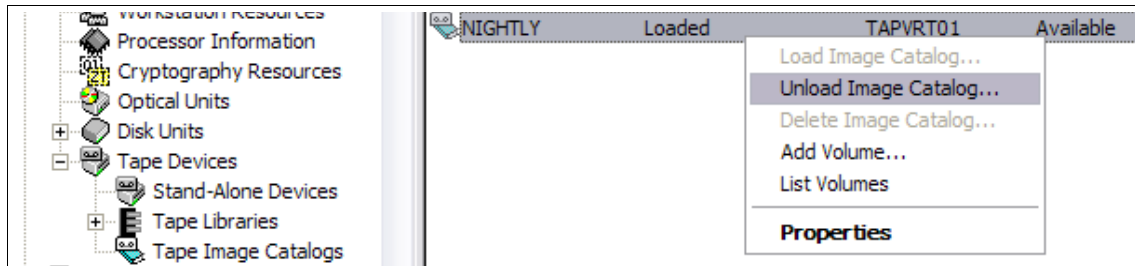

Figure 3-82 Unload image catalog through Navigator

Create a dependent catalog by selecting **Configuration and Service** → **Hardware** → **Tape Devices**. Then right-click **Tape Image Catalogs** and selecting **Create Image Catalog** as shown in Figure 3-83.

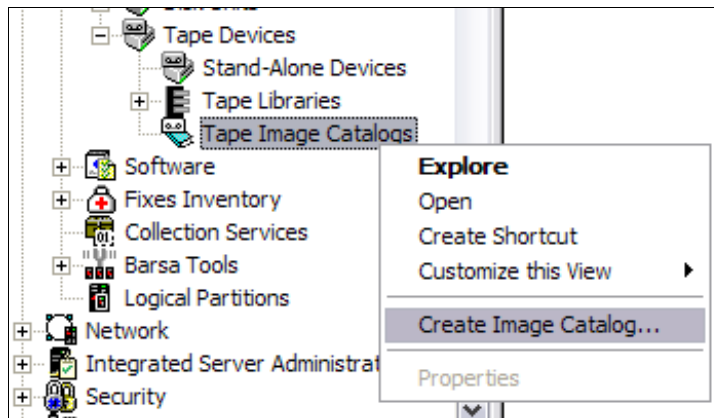

Figure 3-83 Create dependent catalog through Navigator

When the Create Catalog window appears, enter the following parameters:

- ▶ Catalog name (IMGCLG): This specifies the name of the image catalog to be created.
- ▶ Catalog description (TEXT): This specifies up to 50 characters of text that briefly describes the image catalog being created.
- ▶ Directory path (DIR): This specifies the directory to be associated with this image catalog. For dependent catalogs, this parameter must have a value of \*REFIMGCLG. This specifies another image catalog as a reference for the new image catalog.
- ▶ Reference catalog (REFIMGCLG): This specifies the name of the image catalog as a reference for the new image catalog. The new dependent image catalog will contain the image catalog entries that exist in the reference image

catalog at the time the dependent image catalog is created. Any additional changes to the reference image catalog will not be reflected in the dependent image catalog.

- ▶ Create directory (CRTDIR): Specifies whether the directory (DIR parameter) should be created if it does not exist.
  - \*YES: The directory will be created if it does not exist.
  - \*NO: The directory will not be created.
- ▶ Authority level (AUT): Authority level specifies the authority you are giving to users who do not have specific authority for the object, who are not on an authorization list, and whose group profile or supplemental group profiles do not have specific authority for the object. Following are the choices for authority levels:
  - Exclude: (Default) The user cannot access the image catalog unless the user has \*ALLOBJ special authority, the user is the owner of the object, or the user is later granted authority.
  - Library create: The authority for the object is the same as the create authority for QUSRSYS. The create authority for QUSRSYS can be displayed by using the Display Library Description (DSPLIBD) command. If the create authority for QUSRSYS is set to \*SYSVAL, display the QCRTAUT system value. If the create authority is changed with the Change Library (CHGLIB) command, the new authority does not affect existing objects.
  - Change: The user can perform all operations on the object except those limited to the owner or controlled by object existence authority and object management authority. The user can change and perform basic functions on the object. Change authority provides object operational authority and all data authority. If the object is an authorization list, the user cannot add, change, or remove user IDs.
  - All: The user can perform all operations except those limited to the owner or controlled by authorization list management authority. The user can control the object's existence, specify the security for the object, change the object, and perform basic functions on the object. The user also can change ownership of the image catalog.
  - Use: The user can perform basic operations on the image catalog, such as displaying properties. The user cannot change the image catalog, and use authority provides object operational authority, read authority, and execute authority.
  - Name: Specify the name of an authorization list to be used for granting authority to the object. Users included in the authorization list are granted authority to the object as specified in the list. The authorization list must exist when the object is created

Figure 3-84 shows the parameters used to create a dependent catalog called DEPENDENT1, which will automatically set up catalog shadowing.

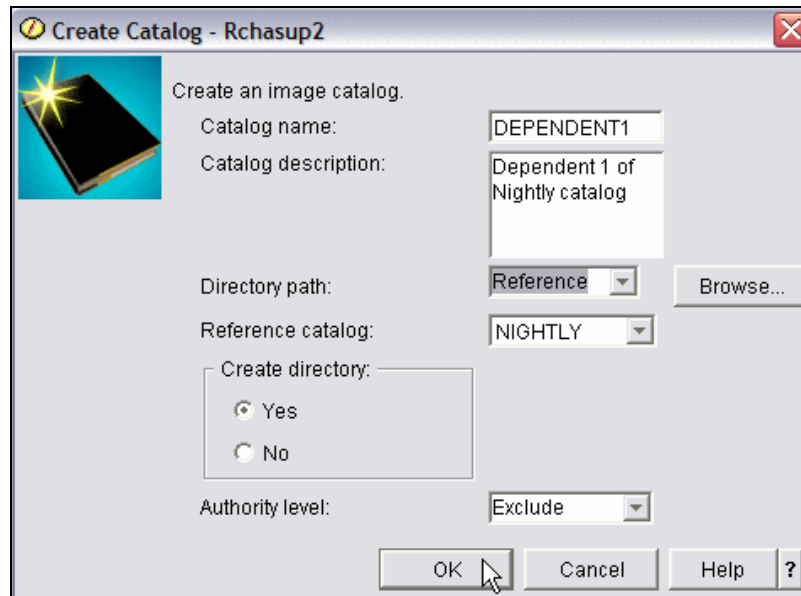

Figure 3-84 Create dependent1 through Navigator

A dependent image catalog is created and catalog shadowing set up.

To view your dependent catalog's volumes, select **Configuration and Service** → **Hardware** → **Tape Devices** → **Tape Image Catalogs**. Then right-click your dependent image catalog and select **List Volumes**, as shown in Figure 3-85.

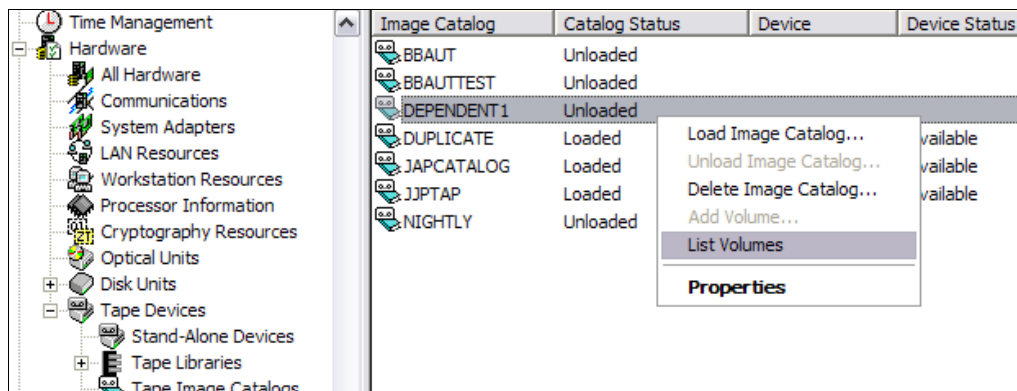

Figure 3-85 List dependent volumes through Navigator

Figure 3-86 shows that the volumes in the dependent catalog DEPENDENT1 contain the same volumes as the reference catalog Nightly, at the time of creation.

The screenshot shows a window titled 'List Volumes - Dependent1 - Rchasup2'. The window has a menu bar with 'File', 'Edit', 'View', and 'Help'. Below the menu bar is a toolbar with icons for cut, copy, paste, delete, and refresh. A status bar in the top right corner indicates '0 minutes old'. The main area contains a table with the following data:

In...	Volume Name	Status	Type	Density	Write Protected	Percent Used	Maximum S...	File Name	Description
007	VOL007	Loaded	Standard labe...	*VRT256K	Yes	0.1	1,000	vol007	Saturdays
008	VOL001	Mounted	Standard labe...	*VRT256K	Yes	5.3	2,000	vol001	Netherland...

At the bottom of the window, a status bar indicates '1 - 2 of 2 objects'.

Figure 3-86 Dependent catalog volumes through Navigator

There is no restriction on the number of dependent catalogs you can create. However, since there is a limit of 35 virtual devices, only 35 dependent catalogs can be in Available or Ready status at the same time.

If using a 5250 emulation session, ensure that the tape image catalog status is Not Ready by issuing the WRKIMGCLGE command:

```
WRKIMGCLGE IMGCLG(NIGHTLY)
```

The top right-hand corner of the screen should show a status of Not Ready, as shown in Figure 3-87 on page 129.

```

Work with Image Catalog Entries
System: RCHITSO
Catalog . . . : NIGHTLY          Status . . . : Not ready
Type . . . . : Tape             Device . . . :
Directory . . : /images/tape/nightly

Type options, press Enter.
1=Add  2=Change  4=Remove  6=Mount  8=Load  9=Unload
10=Initialize volume  11=Display  13=Dump  14=Duplicate

Opt  Index  Status      Volume Name  Density      Type  Write
      *AVAIL
      7  Loaded      VOL007      *VRT256K    *SL  No
      8  Mounted     VOL001      *VRT256K    *SL  Yes

Bottom
F3=Exit  F5=Refresh      F6=Load image catalog  F8=Reorder by index
F11=View size information  F12=Cancel  F22=Display entire field

```

Figure 3-87 Verify status through 5250 emulation

If the status of the image catalog is Ready, press F6 and then press Enter to unload the image catalog, or issue the following command:

```
LODIMGCLG IMGCLG(NIGHTLY) DEV(TAPVRT01) OPTION(*UNLOAD)
```

To create a dependent image catalog, enter the following command:

```
CRTIMGCLG IMGCLG(DEPENDENT1) DIR(*refimgclg) TYPE(*TAP) REFIMGCLG(nightly)
TEXT('Dependent1 of Nightly catalog')
```

Figure 3-88 on page 130 shows the corresponding window.

```

                                Create Image Catalog (CRTIMGCLG)

Type choices, press Enter.

Image catalog . . . . . > DEPENDENT1      Name
Directory . . . . . > *refimgclg

Image catalog type . . . . . > *TAP          *OPT, *TAP
Create directory . . . . . *YES            *YES, *NO
Reference image catalog . . . . > NIGHTLY    Name

                                Additional Parameters

Text 'description' . . . . . > 'Dependent1 of Nightly catalog'

                                                                Bottom
F3=Exit   F4=Prompt   F5=Refresh   F10=Additional parameters   F12=Cancel
F13=How to use this display   F24=More keys

```

Figure 3-88 Create dependent catalog through 5250 emulation

The preceding command creates a dependent image catalog DEPENDENT1 that is created from a snapshot of a non-dependent image catalog NIGHTLY at a single point in time.

**Important:** If volumes are added to the reference catalog NIGHTLY after the dependent catalog DEPENDENT1 is created, that newly added volume will not be visible to the dependent catalog DEPENDENT1.

Work with image Catalogs (WRKIMGCLG) should now show the \*IMGCLG DEPENDENT1. If you press F11 twice, you should see a field called Reference Catalog, and also see the reference catalog listed as NIGHTLY next to your dependent catalog, as shown in Figure 3-89 on page 131.

```

Work with Image Catalogs
System: RCHITSO
Type options, press Enter.
1=Create 2=Change 4=Delete 8=Load 9=Unload 10=Verify
12=Work with entries

  Image      Reference  Catalog
  Opt  Catalog  Catalog   Relationship

  BBAUT
  BBAUTTEST
  DEPENDENT1 NIGHTLY   Dependent
  DUPLICATE
  JAPCATALOG
  JJPTAP
  NIGHTLY           Reference

Bottom

F3=Exit  F5=Refresh  F11=View status  F12=Cancel

```

Figure 3-89 Catalog relationship through 5250 emulation

Select option **12** (WRKIMGCLGE) for DEPENDENT1. You should see the same volumes that were listed in the reference catalog NIGHTLY at the time DEPENDENT1 was created, as shown in Figure 3-90 on page 132.

```

Work with Image Catalog Entries
System: RCHITS0
Catalog . . . : DEPENDENT1      Status . . . : Not ready
Type . . . . : Tape           Device . . . :
Directory . . : /images/tape/nightly

Type options, press Enter.
1=Add  2=Change  4=Remove  6=Mount  8=Load  9=Unload
10=Initialize volume  11=Display  13=Dump  14=Duplicate

Opt  Index  Status      Volume Name  Density      Type  Write
     *AVAIL
      7  Loaded      VOL007      *VRT256K    *SL  Yes
      8  Mounted      VOL001      *VRT256K    *SL  Yes

Bottom
F3=Exit  F5=Refresh      F6=Load image catalog  F8=Reorder by index
F11=View size information  F12=Cancel  F22=Display entire field

```

Figure 3-90 Dependent volumes through 5250 emulation

At this point, you can load your dependent catalog on to a virtual tape device so that its status is Ready. After the status shows Ready, your dependent catalog is ready for operation.

### 3.4.3 Utilizing dependent catalogs

This section discusses some of the operations for which a dependent image catalog can be used after it is created.

A dependent catalog can be used for displaying, restoring, installing, and duplicating a volume while it is being used by another virtual device. A dependent catalog has the ability to work with any of its volumes as long as that specific volume is not *mounted* in the reference catalog. For this reason, you may want to consider creating at least two dependent catalogs per reference catalog if you want to exploit the full potential of catalog shadowing.

A dependent catalog is used similarly to a single or non-dependent image catalog. In order to utilize the volumes, the dependent catalog must be loaded on the virtual optical device and must have a Ready status. After Ready status is

reached, you can display, restore, install, and duplicate a volume even if any of these operations are already being performed by another dependent catalog.

### 3.4.4 Removing a shadowed volume

This section explains how to remove a volume when catalog shadowing is implemented.

#### Removing a reference volume

A virtual volume cannot be removed from a reference catalog if the image is also contained in a dependent catalog. Since an image cannot be deleted from a dependent catalog, the only way to remove an image from the reference catalog is to delete *all* dependent catalogs containing that image file.

This section details how to remove a volume. To remove the entire dependent catalog, refer to 3.4.5, “Deleting a shadowed catalog” on page 135. For details on deleting the entire reference catalog and its dependent catalogs, refer to “Deleting a reference catalog” on page 137.

To remove a volume from a reference image catalog that is not shadowed or whose image file is not contained within a dependent catalog, perform the following tasks:

Select **Configuration and Service** → **Hardware** → **Tape Devices** → **Tape Image Catalogs**. Then right-click your image catalog and select **List Volumes**. Right-click the volume to be removed and select **Remove Volume**, as shown in Figure 3-91 on page 134.

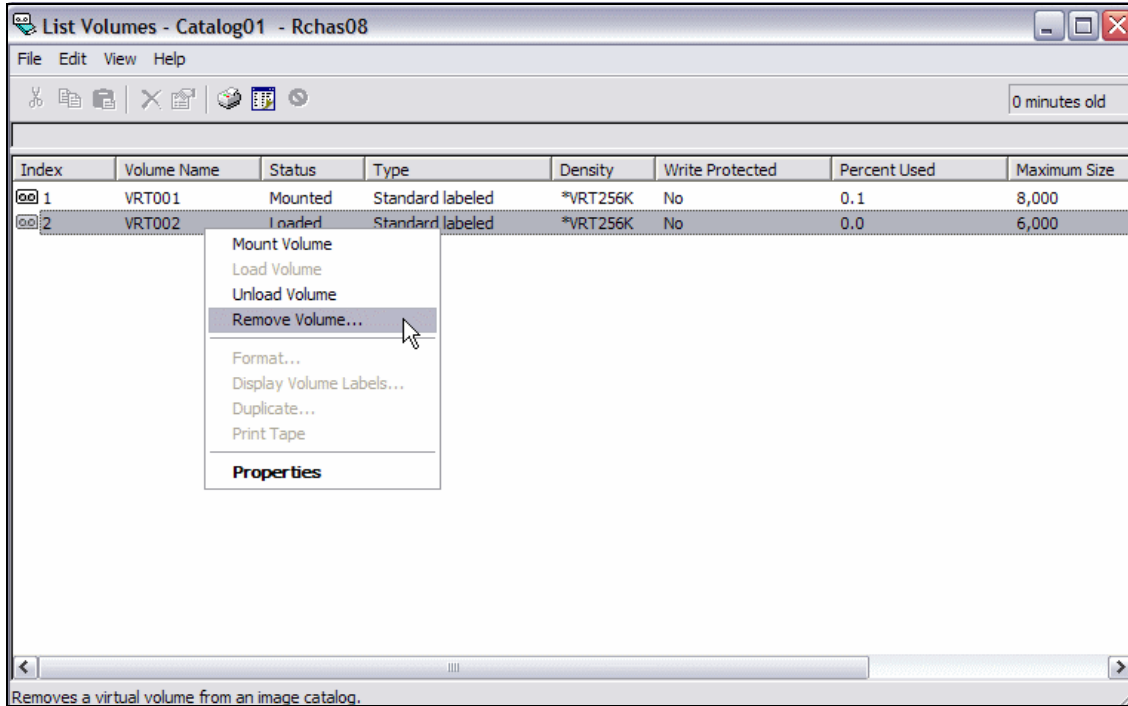

Figure 3-91 Remove non-shadowed volume through Navigator

Then choose whether or not to keep the image files and click **OK**, as shown in Figure 3-92.

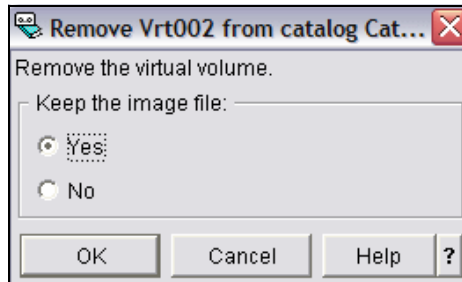

Figure 3-92 Remove non-shadowed volume through Navigator

If using a 5250 emulation session, enter the following command:  
`RMVIMGCLGE IMGCLG(NIGHTLY) IMGCLGIDX(*VOL) VOL(VOL007) KEEP(*NO)`

Figure 3-93 on page 135 shows the corresponding window.

```
Remove Image Catalog Entry (RMVIMGCLGE)

Type choices, press Enter.

Image catalog . . . . . > NIGHTLY      Name
Image catalog index . . . . . > *VOL      1-256, *VOL
Image catalog volume . . . . . > VOL007
Keep image file . . . . . > *NO          *YES, *NO

Bottom
F3=Exit  F4=Prompt  F5=Refresh  F12=Cancel  F13=How to use this display
F24=More keys
```

Figure 3-93 Remove image catalog entry through 5250 emulation

**Note:** If the image file was added *after* the dependent catalogs were created, the dependent catalogs will not contain the volume. Therefore, the dependent catalogs do not have to be deleted.

**Removing a dependent volume**

It is currently not possible to remove a single volume from a dependent catalog. If you do not want the volume in the dependent catalog, delete all the dependent catalogs that contain the volume. Then, remove the volume from the reference catalog. Now the dependent catalogs can be created from the reference catalog again. Finally, add the volume back into the reference catalog.

**3.4.5 Deleting a shadowed catalog**

In this section we explain the correct way to end catalog shadowing or delete a catalog that is shadowed, whether it is a reference catalog or a dependent catalog.

## Ending catalog shadowing

Catalog shadowing can be ended by deleting all dependent image catalogs, as explained here.

## Deleting a dependent catalog

You can identify and delete a reference catalog's dependents by following these steps.

In IBM @server iSeries Navigator, select **Configuration and Service** → **Hardware** → **Tape Devices** → **Tape Image Catalogs**. Your dependent catalogs will have their reference catalog listed under the Reference Catalog field.

Ensure that the dependent catalog's status is Unloaded. If it is not, right-click the dependent catalog and select **Unload Image Catalog**. Then right-click the dependent catalog, select **Delete Image Catalog**, and click **OK**, as shown in Figure 3-94.

Repeat these steps for all dependent catalogs.

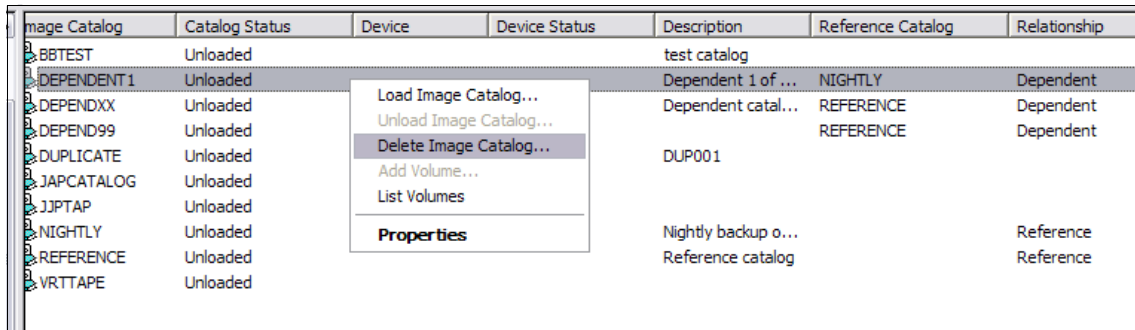

Image Catalog	Catalog Status	Device	Device Status	Description	Reference Catalog	Relationship
BBTEST	Unloaded			test catalog		
DEPENDENT 1	Unloaded			Dependent 1 of ...	NIGHTLY	Dependent
DEPENDXX	Unloaded			Dependent catal...	REFERENCE	Dependent
DEPEND99	Unloaded				REFERENCE	Dependent
DUPLICATE	Unloaded			DUP001		
JAPCATALOG	Unloaded					
JJPTAP	Unloaded					
NIGHTLY	Unloaded			Nightly backup o...		Reference
REFERENCE	Unloaded			Reference catalog		Reference
VRTTAPE	Unloaded					

Figure 3-94 Delete dependent catalog through Navigator

If deleting from a 5250 emulation session, issue the `WRKIMGCLG` command and then press Enter. Press F11, then press F11 again.

Next, identify the dependent catalog's reference catalog by the second field Reference Catalog, and press F11 again.

If the dependent catalog is in a status of Not Ready, then enter 4 (Delete) next to the dependent catalog and press Enter to delete it.

If the dependent catalog is in a status of Ready, then enter 9 (Unload) next to the dependent catalog and press Enter twice. This unloads the image catalog from the virtual tape device.

Now you can enter 4 next to the dependent catalog and then press Enter to delete it.

Figure 3-95 shows the WRKIMGCLG window after F11 has been pressed twice.

```
Work with Image Catalogs                                System:  RCHITS0
Type options, press Enter.
 1=Create  2=Change  4=Delete  8=Load  9=Unload  10=Verify
 12=Work with entries

  Image      Reference  Catalog
Opt Catalog  Catalog    Relationship

BBTEST
DEPENDENT1  NIGHTLY    Dependent
DEPENDXX    REFERENCE  Dependent
DEPEND99    REFERENCE  Dependent
DUPLICATE
JAPCATALOG
JJPTAP
NIGHTLY                    Reference
REFERENCE                  Reference
VRTTAPE
V5R4_450

More...

F3=Exit  F5=Refresh  F11=View status  F12=Cancel
```

Figure 3-95 Identifying dependents through 5250 emulation

A dependent catalog can also be deleted by issuing the following command:

```
DLTIMGCLG IMGCLG(DEPENDENT2)
```

### Deleting a reference catalog

A reference catalog cannot be deleted unless all dependent catalogs are deleted. For this reason, you can manually delete the dependent catalogs first and then delete the reference image catalog, or you can delete the reference and all of its dependent image catalogs at the same time.

In IBM @server iSeries Navigator, select **Configuration and Service** → **Hardware** → **Tape Devices** → **Tape Image Catalogs**. Ensure that the status of your reference and dependent catalogs is shown as Unavailable.

Next, right-click your reference catalog and select **Delete Image Catalog**, as shown in Figure 3-96 on page 138.

Image Catalog	Catalog Status	Device	Device Status	Description	Reference Catalog
BBTEST	Unloaded			test catalog	
DEPENDENT1	Unloaded			Dependent 1 of ...	NIGHTLY
DEPENDXX	Unloaded			Dependent catal...	REFERENCE
DEPEND99	Unloaded				REFERENCE
DUPLICATE	Unloaded			DUP001	
JAPCATALOG	Unloaded				
JJPTAP	Unloaded				
NIGHTLY	Unloaded			Nightly backup o...	
REFERENCE	Unloaded			Reference catalog	
VRTTAPE	Unloaded				

Load Image Catalog...
Unload Image Catalog...
<b>Delete Image Catalog...</b>
Add Volume...
List Volumes
<b>Properties</b>

Figure 3-96 Delete reference catalog through Navigator

To delete dependent catalogs, select **Yes**, and then click **OK**, as shown in Figure 3-97.

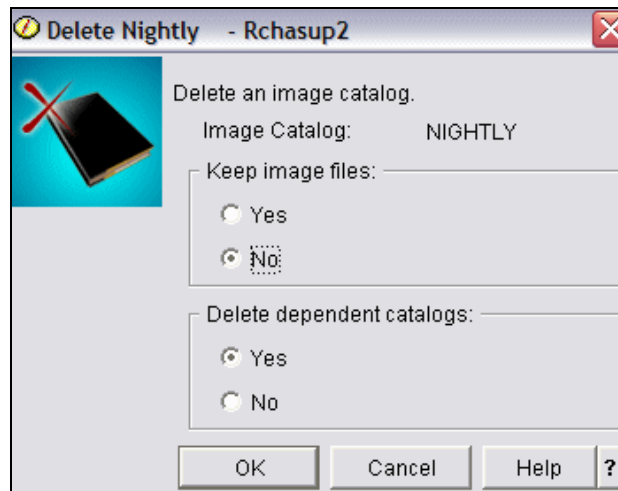

Figure 3-97 Delete catalog options through Navigator

In a 5250 emulation session, issue the following command:

```
DLTIMGCLG IMGCLG(NIGHTLY) KEEP(*NO) DEPIMGCLG(*DELETE)
```

Figure 3-98 on page 139 shows the corresponding window.

```

Delete Image Catalog (DLTIMGCLG)

Type choices, press Enter.

Image catalog . . . . . > NIGHTLY      Name
Keep image files . . . . . > *NO       *YES, *NO
Dependent image catalogs . . . . . > *DELETE *NODELETE, *DELETE

Bottom
F3=Exit  F4=Prompt  F5=Refresh  F12=Cancel  F13=How to use this display
F24=More keys
```

Figure 3-98 Deleting an image catalog through 5250 emulation

**Note:** KEEP(\*NO) will delete the actual image files. If you wish to keep the image files and delete only the image catalog objects (type of \*IMGCLG), leave KEEP as the default of \*YES.





## Multiple virtual tape scenarios

In this chapter we provide a number of scenarios that serve as examples of ways to use virtual tape support. However, these are not the only ways this support can be used, and you will undoubtedly find others. The most useful characteristic of this support is that it is virtual and therefore you can experiment with it, provided you have i5/OS V5R4 installed.

We also explain here how to perform nightly backups using virtual tape, and describe BRMS parallel backup (parallel-parallel and parallel-serial) and SAVSYS using virtual tape.

## 4.1 Nightly backup using virtual tape

In this scenario we perform a daily nightly backup to virtual tape using the i5/OS function Go Backup. Go Backup is a user-friendly interface that assists you in setting up a backup plan using menus.

If you are already using this function, there are several benefits in using virtual tape in a Go Backup environment:

- ▶ No more failed backups due to a wrongly loaded volume  
Many user-written backup applications, including Go Backup, require a specific volume name. You can change that to allow any volume to be loaded. However, that can lead to volumes with active data being overwritten.
- ▶ No manual operator mounts required during the nightly backup  
In many situations, the physical tape drive is a Quarter Inch Cartridge (QIC) using volumes with a small capacity. An operator intervention may be required to mount the next volume, or you may already have modified the backup list to a minimum list in order to get it to fit in one volume. With virtual tape, this is not a concern.
- ▶ No failed backups due to media errors
- ▶ There is no need to schedule the backup on a time stamp when the physical tape drive is available as there is no real device sharing.

Today, there are many i5 systems with two or more partitions using the same physical tape drive that is attached to each partition on a scheduled move basis. With virtual tape, you can create up to 35 virtual tape devices per partition.

### 4.1.1 Preparing for nightly backup

This section summarizes the steps involved in setting up the environment for virtual tape as used in this scenario. If you have already set up one or more items, you can skip that step.

To create the virtual device and varying it, enter the following commands:

```
CRTDEVTAP DEVD(TAPVRT01) RSRNAME(*VRT)
VRYCFG CFGOBJ(TAPVRT01) CFGTYPE(*DEV) STATUS(*ON)
```

To create the image catalog, enter the following command:

```
CRTIMGCLG IMGCLG(CATALOG01) DIR('/MyCatalogDirectory01') TYPE(*TAP)
```

To add the image catalog entries, enter the following commands:

```
ADDIMGCLGE IMGCLG(CATALOG01) FROMFILE(*NEW) TOFILE(VRT001) IMGSIZ(8000)
ALCSTG(*IMGSIZ) VOLNAM(VRT001) DENSITY(*VRT256K)
```

To load the image catalog, enter the following command:

```
LODIMGCLG IMGCLG(CATALOG01) DEV(TAPVRT01)
```

## 4.1.2 Performing the nightly backup

In the i5/OS command line, enter the following command:

```
GO BACKUP
```

Press Enter. A window similar to the one shown in Figure 4-41 appears.

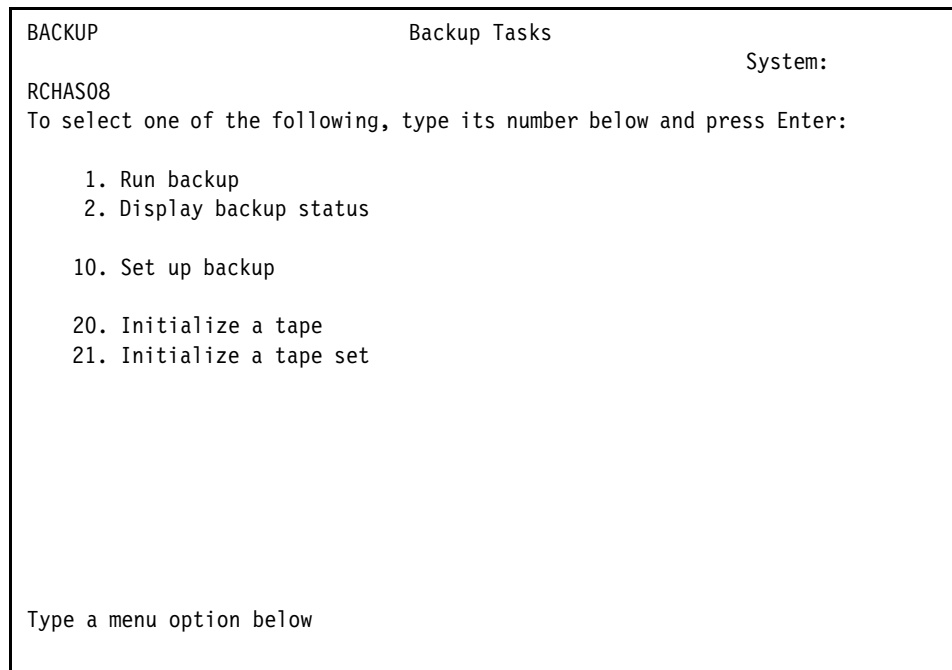

*Figure 4-1 Go backup*

In the command line, type option 10 and press Enter. Figure 4-42 shows the Set Up Backup window.

```

SETUPBCKUP                               Set Up Backup                               System:  RCHAS08
To select one of the following, type its number below and press Enter:

    1. Change daily backup options
    2. Change weekly backup options
    3. Change monthly backup options

   10. Change library backup list
   11. Change folder backup list

   20. Change backup schedule

```

Figure 4-2 Set up backup

In the field Type a menu option below, type 1 and press Enter.

Then change the existing values to match your virtual tape environment, as shown in the following figures.

```

Change Daily Backup Options                               System:  RCHAS08
Type choices below, then press Enter.

Where to back up:
Backup device . . . . . TAPVRT06      Name, F4 for list

Tape sets to rotate . . . . . *ANY      Name, *ANY

Erase tape before backup . . . . . Y      Y=Yes, N=No

More...

```

Figure 4-3 Change daily backup options - 1

```

Change Daily Backup Options
System: RCHAS08
Type choices below, then press Enter.

What to back up:
  User libraries . . . . . 1      1=Selected from list
                                   2=All
                                   3=None
  Folders . . . . . 2      1=Selected from list
                                   2=All
                                   3=None
  User directories . . . . . 2      2=All
                                   3=None
  Security data . . . . . N      Y=Yes, N=No
  Configuration . . . . . N      Y=Yes, N=No

How to back up:
  Save changed objects only . . . . . N      Y=Yes, N=No
  Submit backup as a batch job . . . . . Y      Y=Yes, N=No
  Print detailed report . . . . . Y      Y=Yes, N=No
Bottom

```

Figure 4-4 Change backup options - 2

```

Change Library Backup List
                                                                    System:
RCHAS08
Find library . . . . . Starting characters

Type options below, then press Enter.
  2=Change backup  5=Display library contents  8=Display details

-----Backup----- Last
Opt  Library   Daily   Weekly  Monthly Backup  Changed
-----
QDSNX   Yes     Yes     Yes     12/05/05 No
QGPL    Yes     Yes     Yes     12/08/05 Yes
QMGTC   Yes     Yes     Yes     12/05/05 Yes
QMGTC2  Yes     Yes     Yes     12/05/05 Yes
QMPGDATA Yes     Yes     Yes     Yes     Yes
QPFRDATA Yes     Yes     Yes     12/05/05 Yes
QRCL    Yes     Yes     Yes     12/05/05 Yes
QSRVAGT Yes     Yes     Yes     12/05/05 Yes
QSYS2   Yes     Yes     Yes     12/05/05 Yes
QUSRBRM Yes     Yes     Yes     Yes     Yes
QUSRDIRB Yes     Yes     Yes     12/05/05 Yes

More...

```

Figure 4-5 Change library backup list

Figure 4-5 shows the Change Library Backup window.

```

Change Backup Schedule

Type choices below, then press Enter. Press F4 for list of backups.

Run backup using this schedule . . . . . Y Y=Yes, N=No

                                Backup          Backup Time

Sunday . . . . .
Monday . . . . .
Tuesday . . . . .
Wednesday . . . . . *DAILY          23:00:00
Thursday . . . . .
Friday . . . . .
Saturday . . . . .

Occurrence of day in month to run monthly
backup . . . . . 1-4, *LAST

Hours before backup to send load tape
message . . . . . *NOMSG 1-24, *NOMSG

```

Figure 4-6 Change the backup schedule

Figure 4-6 shows the Change Backup Schedule window.

```

Display Backup Status                                RCHAS08
                                                    12/14/05
19:14:35

What Was Backed Up                                Last
                                                    Backup
                                                    Date
                                                    Tape
                                                    Set
User libraries:
  All . . . . . :
  All (changes only) . . . . . :
  From list . . . . . :
  From list (changes only) . . . . . :
Folders:
  All . . . . . :
  All (changes only) . . . . . :
  From list . . . . . :
User directories:
  All . . . . . :
  All (changes only) . . . . . :
Security data . . . . . :
Configuration . . . . . :

More...

```

Figure 4-7 Display the backup status

Figure 4-7 shows the Display the Backup Status window.

## 4.2 BRMS parallel backup

This section discusses two BRMS parallel backup scenarios: parallel-parallel and parallel-serial. The difference between these two types of parallel saves is as follows:

- ▶ In parallel-parallel, objects are spread across the drives. Objects of library A will be saved on drive 1 and 2, and objects of library B will be saved on drive 1 and 2, and so on.
- ▶ In parallel-serial, the libraries are spread across the drives, but *not* the objects in it. For example, library A will be saved to drive 1 and library B to drive 2, and so on.

For restoring the parallel backups, you require enough drives to achieve an acceptable restore performance. From a purely technical viewpoint, it is possible to restore both types of parallel backups using a media with one drive, or just one

physical drive. From a practical viewpoint, however, this is a time-consuming restore since it results in excessive swapping of mounted volumes.

**Note:** The intention of both parallel scenarios is to show the technical details related to virtual tape in BRMS. However, keep in mind that parallel-parallel is designed for large libraries and objects. On systems with many small libraries or objects, it will perform worse than, for example, concurrent backups, which are backups running at the same time, saving different types of objects.

## 4.2.1 Parallel-parallel scenario

This section describes a scenario with true parallel backup (parallel-parallel).

The parallel backup is performed against two data libraries belonging to a specific application, with each library having three large files of about 1.3 GB. This is a total of 8 GB for both libraries.

The backup will be performed in true parallel with two virtual drives. After the backup is finished, the volumes will be duplicated to physical volumes.

In this scenario, we assume that you have two physical drives supporting 256 K blocksizes or a media library with at least two drives available, supporting 256 K blocksizes. If you have only one drive, it is possible to duplicate the volumes one at a time on one drive. However, for restore, we recommend you use two physical drives.

### Preparing for parallel backup

This section summarizes the steps involved in setting up the environment for virtual tape in BRMS, as used in this scenario. If you have already set up one or more items, you can skip that step.

- ▶ To create the virtual devices and vary them, enter the following commands:

```
CRTDEVTAP DEVD(TAPVRT01) RSRNAME(*VRT)
CRTDEVTAP DEVD(TAPVRT02) RSRNAME(*VRT)
VRYCFG CFGOBJ(TAPVRT01) CFGTYPE(*DEV) STATUS(*ON)
VRYCFG CFGOBJ(TAPVRT02) CFGTYPE(*DEV) STATUS(*ON)
```

- ▶ To create image catalogs, enter the following commands:

```
CRTIMGCLG IMGCLG(CATALOG01) DIR('/MyCatalogDirectory01') TYPE(*TAP)
CRTIMGCLG IMGCLG(CATALOG02) DIR('/MyCatalogDirectory02') TYPE(*TAP)
```

- ▶ To add the image catalog entries, enter the following command:

```
ADDIMGCLGE IMGCLG(CATALOG01) FROMFILE(*NEW) TOFILE(VIR001) VOLNAM(VIR001)
DENSITY(*VRT256K)
```

- ▶ To add additional images, enter the following commands:

```
ADDIMGCLGE IMGCLG(CATALOG02) FROMFILE(*NEW) TOFILE(VIR002) VOLNAM(VIR002)
DENSITY(*VRT256K)
```

- ▶ To create locations VIRTUAL, COPIED, and VAULT, type the following command and press Enter:

```
WRKLOCBRM
```

Now add the following locations, as described in 3.1, “Setting up virtual tape storage” on page 34:

- VIRTUAL
- COPIED, Change Allow volumes to expire to \*YES.

- ▶ To create virtual devices TAPVRT01 and TAPVRT02, enter the following command and press Enter:

```
WRKDEBRM
```

Add the following devices:

- TAPVRT01, Next volume message should be \*N0, change Location to VIRTUAL
- TAPVRT02, Next volume message should be \*N0, change Location to VIRTUAL

- ▶ To create two physical devices, or a tape library with at least two drives  
Refer to 4.2.1, “Parallel-parallel scenario” on page 149 for information about this topic.

- ▶ To create media classes VRT256K and FMT3590H

If you have another type of physical device, you can create or specify your own media class compatible with your device. In this case, since both media classes are already on the system, they do not have to be created.

- ▶ To create move policies TO\_OUTDOOR and TO\_COPIED, type the following command and press Enter:

```
WRKPCYBRM *MOV
```

Add the following locations:

- TO\_COPIED
  - Home location VIRTUAL
  - Verify moves \*NO
  - Seq 10
  - Location COPIED
  - Duration \*EXP
- TO\_OUTDOOR
  - Home location \*HOME

- Seq 10
  - Location VAULT
  - Duration \*EXP
- To create media policy VIRTUAL and FMT3590H, or another media class if you are using another device type and another media class, type the following command and press Enter:

```
WRKPCYBRM *MED
```

Add the following media policies:

- VIRTUAL
  - Retention type 2
  - Retain media 4
  - Move policy TO\_COPIED
  - Media class VRT256K
  - Mark volumes for duplication \*YES.
- FMT3590H
  - Retention type 2
  - Retain media 10
  - Move policy TO\_OUTDOOR
  - Media class \*FMT3590H

## Backup

This section provides information about creating and using a control group named APPLIC01.

To create the backup control group, perform the following tasks:

1. Type the following command:

```
WRKCTLGBRM
```

Then press Enter.

2. Select **1** in the Opt column, and in the Control Group column type APPLIC01, then press Enter.
3. Specify your large libraries in the window shown in Figure 4-48 on page 184, in place sequences 20 and 30.

```

                                Create Backup Control Group Entries                                RCHAS08
Group . . . . . : APPLIC01
Default activity . . . . . FFFFFFFF
Text . . . . . *NONE

Type information, press Enter.

      Backup      Auxiliary  Weekly   Retain   Save     SWA
Seq  Items       List Storage  Activity Object  While   Message
      Type       Pool Device SMTWTF5 Detail  Active  Queue

10  *EXIT
20  DATALIB01      *SYSBAS  *DFTACT  *YES    *NO
30  DATALIB02      *SYSBAS  *DFTACT  *YES    *NO
40  *EXIT

```

Figure 4-8 Create backup control group APPLIC01

4. Then press **Enter**, F3, and Enter again. This will take you back to the Work With Backup Control Groups window.
5. Type 8 in front of control group APPLIC01 and press Enter.
6. Change the options as shown in Figure 4-9 on page 153 and press Enter.

```

Change Backup Control Group Attributes

Group . . . . . : DAILY

Type information, press Enter.

Media policy for:
  Full backups . . . . . VIRTUAL      Name, F4 for list
  Incremental backups . . . . . VIRTUAL  Name, F4 for list
  Backup devices . . . . . TAPVRT01     Name, F4 for list
                                   TAPVRT02

Parallel device resources:
  Minimum resources . . . . . 2         1-32, *NONE, *AVAIL
  Maximum resources . . . . . 2         1-32, *AVAIL, *MIN
  Sign off interactive users . . . . . *NO      *YES, *NO, *BKUPCY
  Sign off limit . . . . . *BKUPCY        0-999 minutes, *BKUPCY
  Default weekly activity . . . . . *BKUPCY    SMTWTFS(F/I), *BKUPCY
  Incremental type . . . . . *BKUPCY        *CUMUL, *INCR, *BKUPCY
  Force full backup days . . . . . *BKUPCY    0-365, *NOMAX, *BKUPCY
                                           More...

```

Figure 4-9 Change backup control group attributes

Notice that we specified two virtual backup devices in this case. However, you can also use \*MEDCLS, in which case up to 32 virtual devices can be used.

- The control group is created and you can submit the backup. To submit the backup, type the following command:

```
STRBKUBRM CTLGRP(APPLIC01)
```

- The backup will now be submitted. Once the backup is completed, enter the following command:

```
WRKMEDBRM
```

- Scroll down virtual volumes, and a window similar to the one illustrated in Figure 4-10 on page 154 will be shown.

Work With Media						System: RCHAS08	
Position to . . . . .			Starting characters				
Type options, press Enter.							
1=Add 2=Change 4=Remove 5=Display 6=Work with serial set 7=Expire							
8=Move 10=Reinitialize ...							
Opt	Volume Serial	Creation Expired Date	Expiration Date	Location	Move Date	Media Class	Dup Sts
	PAR001 +	12/08/05	12/12/05	VIRTUAL	*NONE	VRT256K	1
	PAR002 +	12/08/05	12/12/05	VIRTUAL	*NONE	VRT256K	1
	PAR003 +	12/08/05	12/12/05	VIRTUAL	*NONE	VRT256K	1
	PAR004 +	12/08/05	12/12/05	VIRTUAL	*NONE	VRT256K	1
	VIR001 +	12/08/05	12/12/05	VIRTUAL	*NONE	VRT256K	1
	VIR002 +	12/08/05	12/12/05	VIRTUAL	*NONE	VRT256K	1
	VIR003 +	12/08/05	12/12/05	VIRTUAL	*NONE	VRT256K	1
							More...

Figure 4-10 Work with media showing virtual volumes used

Notice that Dup Sts is 1, which means that the volumes are marked for duplication, but are not duplicated yet.

10. Press F11 in the WRKMEDBRM window to view the Serial and Parallel set information, as shown in Figure 4-11.

Opt	Volume Serial	System	Move Policy	Serial Set	Parallel Set
	PAR001 +	APPN.RCHAS08	TO_COPIED	*YES	*YES
	PAR002 +	APPN.RCHAS08	TO_COPIED	*YES	*YES
	PAR003 +	APPN.RCHAS08	TO_COPIED	*YES	*YES
	PAR004 +	APPN.RCHAS08	TO_COPIED	*YES	*YES
	VIR001 +	APPN.RCHAS08	TO_COPIED	*YES	*YES
	VIR002 +	APPN.RCHAS08	TO_COPIED	*YES	*YES
	VIR003 +	APPN.RCHAS08	TO_COPIED	*YES	*YES

Figure 4-11 WRKMEDBRM, F11 (volume system)

Notice that Parallel Set is \*YES, which means that this is true parallel.

11. Now select option 6 in front of one of the PARxxx volumes and press **Enter**. A window similar to the one illustrated in Figure 4-12 on page 155 is shown.

Opt	Volume Serial	Volume Seq	Expiration Expired	Expiration Date	Location	Move Date	Media Class	Dup Sts
	PAR004	0001		12/12/05	VIRTUAL	*NONE	VRT256K	1
	PAR001	0002		12/12/05	VIRTUAL	*NONE	VRT256K	1
	PAR002	0003		12/12/05	VIRTUAL	*NONE	VRT256K	1
	PAR003	0004		12/12/05	VIRTUAL	*NONE	VRT256K	1

Figure 4-12 Work with serial set of volume PAR002

12. Next, select option **6** in front of one of the VIRxxx volumes and press Enter. A window similar to the one illustrated in Figure 4-13 is shown.

Opt	Volume Serial	Volume Seq	Expiration Expired	Expiration Date	Location	Move Date	Media Class	Dup Sts
	VIR004	0001		12/12/05	VIRTUAL	*NONE	VRT256K	1
	VIR001	0002		12/12/05	VIRTUAL	*NONE	VRT256K	1
	VIR002	0003		12/12/05	VIRTUAL	*NONE	VRT256K	1
	VIR003	0004		12/12/05	VIRTUAL	*NONE	VRT256K	1

Figure 4-13 Work with serial set for volume VIR004

This shows all the volumes in the set. In this parallel backup scenario, there are two sets.

13. To check the space used by the virtual volumes, type the following command:

```
WRKIMGCLG
```

Then press Enter.

14. Now type 12 in front of image catalog01, and press **Enter**. A window similar to the one illustrated in Figure 4-14 is shown.

Opt	Index	Status	Volume Name	Maximum Size	Percent Used
	*AVAIL				
	1	Loaded	VIR001	1000	99.8
	2	Loaded	VIR002	1000	99.8
	3	Mounted	VIR003	1000	64.1
	4	Loaded	VIR004	1000	99.8

Figure 4-14 Work with image catalog entries of catalog01

15. Type the following command:

WRKIMGCLG

Then press Enter.

16. Type 12 in front of image catalog02, and press **Enter**. A window similar to the one illustrated in Figure 4-15 is shown.

Opt	Index	Status	Volume Name	Maximum Size	Percent Used
	*AVAIL				
	1	Loaded	PAR001	1000	99.8
	2	Loaded	PAR002	1000	99.8
	3	Mounted	PAR003	1000	98.4
	4	Loaded	PAR004	1000	99.8

Figure 4-15 Work with image catalog entries of catalog02

## Duplicating the virtual volumes

The data that has been backed up remains on the system.

1. To duplicate the media to physical media, enter the following commands:

```
SBMJOB CMD(DUPMEDBRM VOL(VIR001) FROMDEV(TAPVRT01) TODEV(NET3590)
MEDPCY(FMT3590H) FROMVOL(*SET) SAVMEDINF(*OBJ))
```

```
SBMJOB CMD(DUPMEDBRM VOL(PAR001) FROMDEV(TAPVRT02) TODEV(NET3590)
MEDPCY(FMT3590H) FROMVOL(*SET) SAVMEDINF(*OBJ))
```

In this scenario, we submitted two jobs for duplicating the volume sets. The intention is to show that it is possible to duplicate more than one volume at the same time.

However, the subsystem in which the jobs run must be capable of running two batch jobs at the same time. Another issue that has to be addressed is that, in this case, we have specified volume names for duplication. This is not known in most cases, unless you have a program that checks it.

If you want to schedule the DUPMEDBRM and do not know the volume names, use DUPMEDBRM VOL(\*SEARCH), which requires one job.

2. After duplication is completed, go back to the Work with Media screen, type the following command:

```
WRKMEDBRM
```

Then press Enter, and a window similar to the one illustrated in Figure 4-16 on page 157 is shown.

```

Work With Media
System: RHAS08
Position to . . . . . Starting characters
Type options, press Enter.
 1=Add  2=Change  4=Remove  5=Display  6=Work with serial set  7=Expire
 8=Move 10=Reinitialize ...

  Volume      Creation Expiration      Move      Media      Dup
Opt Serial    Expired   Date      Date      Location  Date      Class     Sts

  PAR001 +      12/08/05 12/12/05  VIRTUAL  *NONE     VRT256K   *
  PAR002 +      12/08/05 12/12/05  VIRTUAL  *NONE     VRT256K   *
  PAR003 +      12/08/05 12/12/05  VIRTUAL  *NONE     VRT256K   *
  PAR004 +      12/08/05 12/12/05  VIRTUAL  *NONE     VRT256K   *
  VIR001 +      12/08/05 12/12/05  VIRTUAL  *NONE     VRT256K   *
  VIR002 +      12/08/05 12/12/05  VIRTUAL  *NONE     VRT256K   *
  VIR003 +      12/08/05 12/12/05  VIRTUAL  *NONE     VRT256K   *
                                          More...

```

Figure 4-16 Work with media after DUPMEDBRM.

Notice that the DupSts column shows \* for the virtual volumes used for backup, which indicates that the volumes are successfully duplicated now.

3. Press F23 to show more options, and type 15 in front of one of the PARxxx volumes, then press **Enter**. A window similar to the one illustrated in Figure 4-17 is shown.

```

Display Duplication Cross Reference      RCHAS08

  Volume  Volume  Expiration  --- Duplication ---  --- Last entry ---
Type Serial Seq    Date      Date      Time      Date      Time
*INP PAR004  1  12/12/05  12/08/05  16:16:11  12/08/05  16:00:21
*INP PAR001  2  12/12/05  12/08/05  16:16:11  12/08/05  16:00:22
*INP PAR002  3  12/12/05  12/08/05  16:16:11  12/08/05  16:00:22
*INP PAR003  4  12/12/05  12/08/05  16:16:11  12/08/05  16:00:22
*OUT SAM276  1  12/18/05  12/08/05  16:16:11  12/08/05  16:00:22

```

Figure 4-17 Display duplicate volumes for volume PAR002

4. Press F23 again to show more options, and type 15 in front of one of the VIRxxx volumes, then press **Enter**. A window similar to the one illustrated in Figure 4-18 on page 158 is shown.

Display Duplication Cross Reference							RCHAS08
Type	Volume Serial	Volume Seq	Expiration Date	--- Duplication Date	--- Duplication Time	--- Last entry Date	--- Last entry Time
*INP	VIR004	1	12/12/05	12/08/05	16:15:56	12/08/05	16:00:21
*INP	VIR001	2	12/12/05	12/08/05	16:15:56	12/08/05	16:00:22
*INP	VIR002	3	12/12/05	12/08/05	16:15:56	12/08/05	16:00:22
*INP	VIR003	4	12/12/05	12/08/05	16:15:56	12/08/05	16:00:22
*OUT	SAM275	1	12/18/05	12/08/05	16:15:56	12/08/05	16:00:22

Figure 4-18 Display duplicate volumes for volume VIR003

## Moving the volumes

At this point, the volumes are duplicated and now have to be moved. The physical volumes must be moved to bring the data to a safe offsite place (VAULT), and the virtual volumes should be moved to a location where they can expire.

In this scenario, for virtual volumes, locations are set up and policies moved in such a way that data will not be lost if duplication is not performed within the retention days as specified in the media policy.

To move the volumes, enter the following commands:

```
MOVMEBDM MOVPCY(TO_OUTDOOR)
MOVMEBDM MOVPCY(TO_COPIED)
```

The data is saved now and the virtual volumes can be reused once they are expired.

## Recovery using the parallel backup

Now assume that you want to restore the libraries of the application that was saved in this scenario.

To determine which volumes are needed and what the steps are for restoring the libraries, you have to create a recovery report first.

Type the following command:

```
STRRCYBDM OPTION(*CTLGRP) ACTION(*REPORT) CTLGRP((APPLIC01))
```

Two reports will be generated now, with spooled file names QP1ARCY and QP1A2RCY. QP1ARCY is a full recovery report, describing every step required to recover the specified items. QP1A2RCY is a Recovery Volume Summary Report,

which lists all the volumes required for recovering the items you specified. This report is shown in Figure 4-19.

5722BR1 V5R4M0 060210 Recovery Volume Summary Report						
Volume	Media	Creation	Expiration	Location	Storage	
Serial	Expired	Class	Date	Date	Date	Location
SAM275		FMT3590TMP	12/08/05	12/18/05	*NONE	NET3590
	Duplicate	volume(s)	. . . . . : VIR004			
SAM276		FMT3590TMP	12/08/05	12/18/05	*NONE	NET3590
	Duplicate	volume(s)	. . . . . : PAR004			

Figure 4-19 Recovery volume summary report

Assume that the virtual volumes are still on the system and you have to recover the items as described. In that case use this command:

```
STRRCYBRM OPTION(*CTLGRP) ACTION(*REPORT) CTLGRP((APPLIC01)) USEDUPMED(*YES)
```

The Recovery Volume Summary Report will now look as shown in Figure 4-20.

5722BR1 V5R4M0 060210 Recovery Volume Summary Report						
Volume	Media	Creation	Expiration	Location	Storage	
Serial	Expired	Class	Date	Date	Date	Location
PAR001		VRT256K	12/08/05	12/12/05	*NONE	VIRTUAL
	Duplicate	volume(s)	. . . . . : SAM276			
PAR002		VRT256K	12/08/05	12/12/05	*NONE	VIRTUAL
PAR003		VRT256K	12/08/05	12/12/05	*NONE	VIRTUAL
PAR004		VRT256K	12/08/05	12/12/05	*NONE	VIRTUAL
VIR001		VRT256K	12/08/05	12/12/05	*NONE	VIRTUAL
	Duplicate	volume(s)	. . . . . : SAM275			
VIR002		VRT256K	12/08/05	12/12/05	*NONE	VIRTUAL
VIR003		VRT256K	12/08/05	12/12/05	*NONE	VIRTUAL
VIR004		VRT256K	12/08/05	12/12/05	*NONE	VIRTUAL
Total volumes needed for recovery . . . . . :						8

Figure 4-20 Recovery volume summary report using duplicate media

However, this is still a report. For actual restore, as described in the full recovery report QP1A2RCY, type the following command:

```
STRRCYBRM OPTION(*CTLGRP) ACTION(*RESTORE) CTLGRP((APPLIC01))
```

Then press Enter. Figure 4-21 on page 160 shows a list of items you can select to restore.

Select Recovery Items							RCHAS08	
							Select action . . . . . : *ALL	
							Select volume . . . . . :	
Type options, press Enter.								
1=Select 4=Remove 5=Display 7=Specify object								
Opt	Item	Saved	Save	Save	Parallel	Volume	File	Expire
		Date	Time	Type	Devices	Serial	Sequence	Date
	DATALIB01	12/08/05	16:00:21	*FULL	2	SAM275	1	12/18/05
	DATALIB02	12/08/05	16:00:22	*FULL	2	SAM275	2	12/18/05

Figure 4-21 Select items for recovery using physical media (USEDUPMED(\*NO))

If you still have virtual volumes on the system, use the following command:

```
STRRCYBRM OPTION(*CTLGRP) ACTION(*RESTORE) CTLGRP((APPLIC01)) USEDUPMED(*YES)
```

Figure 4-22 shows the list.

Select Recovery Items							RCHAS08	
							Select action . . . . . : *ALL	
							Select volume . . . . . :	
Type options, press Enter.								
1=Select 4=Remove 5=Display 7=Specify object								
Opt	Item	Saved	Save	Save	Parallel	Volume	File	Expire
		Date	Time	Type	Devices	Serial	Sequence	Date
	DATALIB01	12/08/05	16:00:21	*FULL	2	VIR004 +	1	12/12/05
	DATALIB02	12/08/05	16:00:22	*FULL	2	VIR001 +	2	12/12/05

Figure 4-22 Select items for recovery using physical media (USEDUPMED(\*YES))

You will see that the physical and virtual volumes are “switched” when the virtual volumes are duplicated to physical volumes. This happens only for virtual volumes and is logical, because the virtual volumes are supposed to be temporary and are supposed to be removed when they are duplicated.

**Note:** After a volume or set of volumes is duplicated to physical media, the volumes on the recovery report will be “switched” in order to reflect the physical volumes on the recovery report. However, this happens only once. In case of subsequent duplicates of the same volume set, the recovery report will show the first copied physical volume.

## 4.2.2 Parallel-serial backup

This section discusses a parallel-serial backup scenario. Parallel backups are performed on two or more drives, in which the libraries are spread across the drives, but not the objects.

Follow the steps outlined in “Preparing for parallel backup” on page 149 for initial preparation. The parallel backup described in this section will be performed for a \*ALLUSR backup. No save while active will be used in this case. \*ALLUSR can only be saved in parallel-serial, and not in parallel-parallel.

The same environment, drives, locations, policies, and so on described in “Preparing for parallel backup” on page 149, will be used in this scenario too. Only the save items in the control group will be different.

### Backup

This section provides information about creating and using a control group named DAILY.

To create the backup control group, perform the following tasks:

1. Enter the following command:

```
WRKCTLGBRM
```

Then press Enter.

2. Select **1** in the Opt column in the Control Group column type DAILY and press Enter.
3. Specify the same sequences, as shown in Figure 4-23 on page 162.

```

                                Create Backup Control Group Entries                                RCHAS08
Group . . . . . : DAILY
Default activity . . . . . *BKUPCY
Text . . . . . *NONE

Type information, press Enter.

      Backup      Auxiliary  Weekly  Retain  Save      SWA
Seq  Items       List  Storage  Activity Object  While  Message
      Type  Pool Device SMTWTFS  Detail  Active  Queue

10 *EXIT                                *DFTACT
20 *ALLUSR          *SYSBAS  *DFTACT  *YES   *NO
30 *EXIT                                *DFTACT

```

Figure 4-23 Create backup control group DAILY

4. Press Enter, then press F3, and Enter again. This will take you back to the Work With Control Groups window.
5. Type 8 in front of control group DAILY and press Enter.
6. Change the options as shown in Figure 4-24 on page 163 and press Enter.

```

Change Backup Control Group Attributes

Group . . . . . : DAILY

Type information, press Enter.

Media policy for:
  Full backups . . . . . VIRTUAL      Name, F4 for list
  Incremental backups . . . . . VIRTUAL  Name, F4 for list
  Backup devices . . . . . TAPVRT01     Name, F4 for list
                                     TAPVRT02

Parallel device resources:
  Minimum resources . . . . . 2         1-32, *NONE, *AVAIL
  Maximum resources . . . . . 2         1-32, *AVAIL, *MIN
  Sign off interactive users . . . . . *NO      *YES, *NO, *BKUPCY
  Sign off limit . . . . . *BKUPCY        0-999 minutes, *BKUPCY
  Default weekly activity . . . . . *BKUPCY    SMTWTFS(F/I), *BKUPCY
  Incremental type . . . . . *BKUPCY        *CUMUL, *INCR, *BKUPCY
  Force full backup days . . . . . *BKUPCY    0-365, *NOMAX, *BKUPCY
                                           More...

```

Figure 4-24 Change backup control group attributes

Notice that we specified two virtual backup devices in this case. However, you can also use \*MEDCLS, in which case up to 32 virtual devices can be used.

- The new control group DAILY is now created. It can now be submitted for backup. Type the following command:

```
STRBKUBRM CTLGRP(DAILY)
```

- The backup is submitted. Once the backup is completed, enter the following command:

```
WRKMEDBRM
```

- Scroll down the page to the virtual volumes. A window similar to the one illustrated in Figure 4-25 on page 164 is shown.

```

Work With Media
System: RCHAS08
Position to . . . . . Starting characters
Type options, press Enter.
1=Add 2=Change 4=Remove 5=Display 6=Work with serial set 7=Expire
8=Move 10=Reinitialize ...

Volume      Creation Expiration      Move      Media      Dup
Opt Serial   Expired  Date      Date      Location  Date      Class     Sts
PAR001      *YES    12/05/05 12/05/05  VIRTUAL   12/05/05  VRT256K
PAR002      *YES    12/05/05 *NONE     VIRTUAL   12/05/05  VRT256K
PAR003      *YES    12/05/05 12/05/05  VIRTUAL   12/05/05  VRT256K
PAR004      *YES    12/05/05 12/05/05  VIRTUAL   12/05/05  VRT256K
PAR005 +      12/05/05 12/09/05  VIRTUAL   12/05/05  VRT256K      1
PAR006 +      12/05/05 12/09/05  VIRTUAL   12/05/05  VRT256K      1
VIR001      *YES    12/05/05 12/05/05  VIRTUAL   12/05/05  VRT256K
More...

```

Figure 4-25 Work with media showing virtual volumes used for DAILY backup

10. Scroll down the page to view the next window illustrated in Figure 4-26, which shows the other virtual volumes used.

```

Work With Media
System: RCHAS08
Position to . . . . . Starting characters
Type options, press Enter.
1=Add 2=Change 4=Remove 5=Display 6=Work with serial set 7=Expire
8=Move 10=Reinitialize ...

Volume      Creation Expiration      Move      Media      Dup
Opt Serial   Expired  Date      Date      Location  Date      Class     Sts
VIR002      *YES    12/05/05 *NONE     VIRTUAL   12/05/05  VRT256K
VIR003 +      12/05/05 12/09/05  VIRTUAL   12/05/05  VRT256K      1
VIR004 +      12/05/05 12/09/05  VIRTUAL   12/05/05  VRT256K      1
VIR005 +      12/05/05 12/09/05  VIRTUAL   12/05/05  VRT256K      1
VIR006 +      12/05/05 12/09/05  VIRTUAL   12/05/05  VRT256K      1
Bottom

```

Figure 4-26 Work with media showing other virtual volumes

You will see that PAR005, PAR006, VIR003, VIR004, VIR005, and VIR006 are used for the backup. The DupSts is 1, which means that the volumes are marked for duplication, but are not duplicated yet.

11. Press F11 to view the Serial and Parallel set information shown in Figure 4-27.

```

Work With Media
System: RCHAS08
Position to . . . . . Starting characters
Type options, press Enter.
 1=Add  2=Change  4=Remove  5=Display  6=Work with serial set  7=Expire
 8=Move 10=Reinitialize ...

  Volume
Opt  Serial  System      Move      Serial  Parallel
      Serial  System      Policy    Set     Set
-----
PAR001 APPN.RCHAS08 TO_COPIED *NO     *NO
PAR002 APPN.RCHAS08 *NONE    *NO     *NO
PAR003 APPN.RCHAS08 TO_COPIED *NO     *NO
PAR004 APPN.RCHAS08 TO_COPIED *NO     *NO
PAR005 + APPN.RCHAS08 TO_COPIED *YES    *NO
PAR006 + APPN.RCHAS08 TO_COPIED *YES    *NO
VIR001 APPN.RCHAS08 TO_COPIED *NO     *NO
More...

```

Figure 4-27 WRKMEDBRM, F11 (volume system)

12. Scroll down the page to view the next screen showing the other virtual volumes used; see Figure 4-28 on page 166.

Work With Media					
					System: RCHAS08
Position to . . . . .			Starting characters		
Type options, press Enter.					
1=Add 2=Change 4=Remove 5=Display 6=Work with serial set 7=Expire					
8=Move 10=Reinitialize ...					
Opt	Volume Serial	System	Move Policy	Serial Set	Parallel Set
	VIR002	APPN.RCHAS08	*NONE	*NO	*NO
	VIR003 +	APPN.RCHAS08	TO_COPY	*YES	*NO
	VIR004 +	APPN.RCHAS08	TO_COPY	*YES	*NO
	VIR005 +	APPN.RCHAS08	TO_COPY	*YES	*NO
	VIR006 +	APPN.RCHAS08	TO_COPY	*YES	*NO
Bottom					

Figure 4-28 WRKMEDBRM, F11 (Volume system) next screen

As indicated in the Parallel Set column, this is not parallel-parallel (true parallel), but rather parallel-serial.

- Select option **6** in front of one of the PARxxx volumes and press Enter. Figure 4-29 is displayed.

Opt	Volume Serial	Volume Seq	Expiration Date	Location	Move Date	Media Class	Dup Sts
	PAR005	0001	12/09/05	VIRTUAL	*NONE	VRT256K	1
	PAR006	0002	12/09/05	VIRTUAL	*NONE	VRT256K	1

Figure 4-29 Work with serial set of volume PAR005

- Now select option **6** in front of one of the VIRxxx volumes, and press Enter. This displays a window similar to the one shown in Figure 4-30.

Volume Opt	Volume Serial	Volume Seq	Expiration Expired	Expiration Date	Location	Move Date	Media Class	Dup Sts
	VIR003	0001		12/09/05	VIRTUAL	*NONE	VRT256K	1
	VIR004	0002		12/09/05	VIRTUAL	*NONE	VRT256K	1
	VIR005	0003		12/09/05	VIRTUAL	*NONE	VRT256K	1
	VIR006	0004		12/09/05	VIRTUAL	*NONE	VRT256K	1

Figure 4-30 Work with serial set for volume VIR004

This shows all the volumes in the set. Although this is parallel-serial, there are two sets as in parallel-parallel.

15. To view the space used by the virtual volumes, enter the following command:

```
WRKIMGCLG
```

Then press Enter.

16. Type 12 in front of image catalog01, and press Enter. This displays a window similar to Figure 4-31.

Opt	Index	Status	Volume Name	Maximum Size	Percent Used
	*AVAIL				
	1	Loaded	VRT001	1000	.1
	2	Loaded	VRT002	1000	.1
	3	Loaded	VRT003	1000	99.8
	4	Loaded	VRT004	1000	99.8
	5	Loaded	VRT005	1000	99.8
	6	Mounted	VRT006	1000	21.6
	7	Loaded	VRT007	1000	.0
					More...

Figure 4-31 Work with image catalog entries of catalog01

17. Type the following command:

```
WRKIMGCLG
```

Then press Enter.

18. Type 12 in front of image catalog02, and press Enter. A window similar to the one shown in Figure 4-32 on page 168 is displayed.

Opt	Index	Status	Volume Name	Size	Used
	*AVAIL				
	1	Loaded	PAR001	1000	.1
	2	Loaded	PAR002	1000	.1
	3	Loaded	PAR003	1000	.1
	4	Loaded	PAR004	1000	.1
	5	Loaded	PAR005	1000	99.8
	6	Mounted	PAR006	1000	33.1
	7	Loaded	PAR007	1000	.0

More...

Figure 4-32 Work with image catalog entries of catalog02

### Duplicating the virtual volumes

The data that has been backed up is still available on the system. To duplicate the media to physical media, perform the following tasks:

1. Enter the following command:

```
SBMJOB CMD(DUPMEDBRM VOL(PAR005) FROMDEV(TAPVRT01) TODEV(NET3590)
MEDPCY(FMT3590H) FROMVOL(*SET) SAVMEDINF(*OBJ))
```

```
SBMJOB CMD(DUPMEDBRM VOL(VIR003) FROMDEV(TAPVRT02) TODEV(NET3590)
MEDPCY(FMT3590H) FROMVOL(*SET) SAVMEDINF(*OBJ))
```

The same command that was used for the parallel-parallel backup is used.

2. After duplication is complete, go back to the Work with Media window. Type the following command:

```
WRKMEDBRM
```

Then press Enter. This will display Figure 4-33 on page 169.

```

Work With Media
System: RCHAS08
Position to . . . . . Starting characters
Type options, press Enter.
1=Add 2=Change 4=Remove 5=Display 6=Work with serial set 7=Expire
8=Move 10=Reinitialize ...

Volume      Creation Expiration      Move      Media      Dup
Opt Serial   Expired   Date      Date      Location  Date      Class     Sts
PAR001      *YES     12/05/05  12/05/05  VIRTUAL   12/05/05  VRT256K
PAR002      *YES     12/05/05  *NONE     VIRTUAL   12/05/05  VRT256K
PAR003      *YES     12/05/05  12/05/05  VIRTUAL   12/05/05  VRT256K
PAR004      *YES     12/05/05  12/05/05  VIRTUAL   12/05/05  VRT256K
PAR005 +    12/05/05  12/09/05  VIRTUAL   12/05/05  VRT256K  *
PAR006 +    12/05/05  12/09/05  VIRTUAL   12/05/05  VRT256K  *
VIR001      *YES     12/05/05  12/05/05  VIRTUAL   12/05/05  VRT256K
More...

```

Figure 4-33 Work with media after DUPMEDBRM

3. Scroll down the page to the WRKMEDBRM window to see the other virtual volumes, as shown in Figure 4-34.

```

Work With Media
System: RCHAS08
Position to . . . . . Starting characters
Type options, press Enter.
1=Add 2=Change 4=Remove 5=Display 6=Work with serial set 7=Expire
8=Move 10=Reinitialize ...

Volume      Creation Expiration      Move      Media      Dup
Opt Serial   Expired   Date      Date      Location  Date      Class     Sts
VIR002      *YES     12/05/05  *NONE     VIRTUAL   12/05/05  VRT256K
VIR003 +    12/05/05  12/09/05  VIRTUAL   12/05/05  VRT256K  *
VIR004 +    12/05/05  12/09/05  VIRTUAL   12/05/05  VRT256K  *
VIR005 +    12/05/05  12/09/05  VIRTUAL   12/05/05  VRT256K  *
VIR006 +    12/05/05  12/09/05  VIRTUAL   12/05/05  VRT256K  *

```

Figure 4-34 Next screen of work with media after DUPMEDBRM

You will see that the DupSts column shows \* for the virtual volumes used for backup, which indicates that the volumes are successfully duplicated.

4. Press F23 to display more options, then type 15 in front of one of the PARxxx volumes and press Enter. The window in Figure 4-35 is shown.

Display Duplication Cross Reference						RCHAS08	
Type	Volume Serial	Volume Seq	Expiration Date	--- Duplication Date	--- Duplication Time	--- Last entry Date	--- Last entry Time
*INP	PAR005	1	12/09/05	12/05/05	15:51:32	12/05/05	15:22:09
*INP	PAR006	2	12/09/05	12/05/05	15:51:32	12/05/05	15:22:08
*OUT	SAM223	1	12/15/05	12/05/05	15:51:32	12/05/05	15:22:09

Figure 4-35 Display duplicate volumes for volume PAR005

5. Press F23 again to display more options, then type 15 in front of one of the VIRxxx volumes and press Enter. The window in Figure 4-36 is shown.

Display Duplication Cross Reference						RCHAS08	
Type	Volume Serial	Volume Seq	Expiration Date	--- Duplication Date	--- Duplication Time	--- Last entry Date	--- Last entry Time
*INP	VIR003	1	12/09/05	12/05/05	15:50:06	12/05/05	15:22:09
*INP	VIR004	2	12/09/05	12/05/05	15:50:06	12/05/05	15:22:08
*INP	VIR005	3	12/09/05	12/05/05	15:50:06	12/05/05	15:30:01
*INP	VIR006	4	12/09/05	12/05/05	15:50:06	12/05/05	15:30:35
*OUT	SAM220	1	12/15/05	12/05/05	15:50:06	12/05/05	15:30:35

Figure 4-36 Display duplicate volumes for volume VIR003.

## Moving the volumes

The volumes are now duplicated and have to be moved. The physical volumes must be moved to bring the data to a safe offsite place (VAULT) and the virtual volumes should be moved to a location where they can expire.

Set up the locations and move policies in this scenario for virtual volumes in such a way that data will not be lost if the duplication is not performed within the retention days as specified in the media policy.

To move volumes, enter the following commands:

```
MOVMEDBRM MOVPCY(TO_OUTDOOR)
MOVMEDBRM MOVPCY(TO_COPIED)
```

The data is saved and the virtual volumes can be reused once they are expired.

## Recovery using parallel backup

Assume that you want to restore the libraries of the application you saved in this scenario. To determine which volumes are needed and what steps should be created for restoring the libraries, create a recovery report first.

Type the following command:

```
STRRCYBRM OPTION(*ALLUSR) ACTION(*REPORT)
```

Two reports will be generated, with the spooled file names QP1ARCY and QP1A2RCY. QP1ARCY is a full recovery report, describing every step required to recover the specified items. It is a Recovery Volume Summary Report, which lists all the volumes required for recovering the specified items. This report is shown in Figure 4-37.

5722BR1 V5R4M0 060210 Recovery Volume Summary Report							RCHAS08
Volume	Media	Creation	Expiration	Location	Storage	Volume	
Serial	Expired	Class	Date	Date	Date	Location	Slot
SAM220		FMT3590TMP	12/05/05	12/15/05	*NONE	NET3590	
	Duplicate	volume(s)	. . . . . : VIR003				
SAM223		FMT3590TMP	12/05/05	12/15/05	*NONE	NET3590	
	Duplicate	volume(s)	. . . . . : PAR005				
Total volumes needed for recovery . . . . . :						4	

Figure 4-37 Select items for recovery using physical media (USEDUPMED(\*NO

Assume that the virtual volumes are still on the system and you have to recover the items as described. Use the following command:

```
STRRCYBRM OPTION(*ALLUSR) ACTION(*REPORT) USEDUPMED(*YES)
```

The Recovery Volume Summary Report will look as shown in Figure 4-38 on page 172.

5722BR1 V5R4M0 060210 Recovery Volume Summary Report							RCHAS08
Volume	Media	Creation	Expiration	Location	Storage	Volume	
Serial	Expired	Class	Date	Date	Location	Slot	
PAR005		VRT256K	12/05/05	12/09/05	*NONE	VIRTUAL	1
	Duplicate	volume(s)	. . . . . : SAM223				
PAR006		VRT256K	12/05/05	12/09/05	*NONE	VIRTUAL	5
VIR003		VRT256K	12/05/05	12/09/05	*NONE	VIRTUAL	6
	Duplicate	volume(s)	. . . . . : SAM220				
VIR004		VRT256K	12/05/05	12/09/05	*NONE	VIRTUAL	7
VIR005		VRT256K	12/05/05	12/09/05	*NONE	VIRTUAL	8
VIR006		VRT256K	12/05/05	12/09/05	*NONE	VIRTUAL	18
Total volumes needed for recovery . . . . . :							7

Figure 4-38 Select items for recovery using physical media (USEDUPMED(\*YES))

However, this is still a report. For carrying out an actual restore as described in the full recovery report QP1A2RCY, type the following command:

```
STRRCYBRM OPTION(*ALLUSR) ACTION(*RESTORE)
```

Then press Enter.

This displays a list of items you can select to restore, as shown in Figure 4-39 on page 173.

```

Select Recovery Items                                RCHAS08

Select action . . . . . : *ALL
Select volume . . . . . :

Type options, press Enter.
  1=Select  4=Remove  5=Display  7=Specify object

  Saved      Save      Save      Save      Parallel Volume      File      Expire
Opt Item     Date      Time      Type      Devices  Serial      Sequence  Date
QDSNX      12/05/05  15:22:08 *FULL                      SAM220      24      12/15/05
QGPL       12/05/05  15:22:08 *FULL                      SAM220      3       12/15/05
QMGTC      12/05/05  15:22:08 *FULL                      SAM223      23      12/15/05
QMGTC2     12/05/05  15:22:08 *FULL                      SAM220      25      12/15/05
QPFRRDATA  12/05/05  15:22:08 *FULL                      SAM223      24      12/15/05
QRCL       12/05/05  15:22:08 *FULL                      SAM223      25      12/15/05
QSRVAGT    12/05/05  15:22:08 *FULL                      SAM223      26      12/15/05
QSYS2      12/05/05  15:22:08 *FULL                      SAM220      2       12/15/05
QS36F      12/05/05  15:22:08 *FULL                      SAM223      27      12/15/05
QUSRDIRDB  12/05/05  15:22:08 *FULL                      SAM220      27      12/15/05
QUSRIJS    12/05/05  15:22:08 *FULL                      SAM220      28      12/15/05
More...

F3=Exit  F5=Refresh  F9=Recovery defaults  F11=Object View
F12=Cancel  F14=Submit to batch  F16=Select

```

Figure 4-39 Start recovery BRM

You will see that this Select Recovery Items window has two new input fields in V5R4. In releases prior to V5R4, all the items on this window could be selected by pressing F16, or they could be selected one by one.

In V5R4, although F16 can still select all the items, you can change the \*ALL value in the upper right corner to \*VOL to specify a specific volume, change it to \*VOLSET for a volume set, or change it to \*CLROPT to clear the selected options in the Opt column.

If you still have virtual volumes on the system, use the following command:

```
STRRCYBRM OPTION(*ALLUSR) ACTION(*RESTORE) USEDUPMED(*YES)
```

The list that was initially shown in Figure 4-22 on page 160 is now shown in Figure 4-40 on page 174.

```

Select Recovery Items                                RCHAS08

Select action . . . . . : *ALL
Select volume . . . . . :

Type options, press Enter.
 1=Select  4=Remove  5=Display  7=Specify object

  Saved      Save      Save      Save      Parallel Volume      File      Expire
pt Item      Date      Time      Type      Devices  Serial      Sequence  Date
QDSNX      12/05/05  15:22:08 *FULL      VIR004      24      12/09/05
QGGL      12/05/05  15:22:08 *FULL      VIR003      3       12/09/05
QMGTC      12/05/05  15:22:08 *FULL      PAR006      23      12/09/05
QMGTC2     12/05/05  15:22:08 *FULL      VRT004      25      12/09/05
QPFRDATA   12/05/05  15:22:08 *FULL      PAR006      24      12/09/05
QRCL       12/05/05  15:22:08 *FULL      PAR006      25      12/09/05
QSRVAGT    12/05/05  15:22:08 *FULL      PAR006      26      12/09/05
QSYS2      12/05/05  15:22:08 *FULL      VIR003      2       12/09/05
QS36F      12/05/05  15:22:08 *FULL      PAR006      27      12/09/05
QUSRDIRDB  12/05/05  15:22:08 *FULL      VIR005      27      12/09/05
QUSRIJS    12/05/05  15:22:08 *FULL      VIR005      28      12/09/05
More...

```

Figure 4-40 Start recovery BRM using duplicated media

The physical and virtual volumes are “switched” when the virtual volumes are duplicated to physical volumes. This happens only for virtual volumes and is logical, since the virtual volumes are supposed to be temporary and are supposed to be removed when they are duplicated.

### 4.3 SAVSYS using virtual tape

In case of a full system recovery, the first item to be installed or restored is System Licensed Internal Code (SLIC). This is saved with the SAVSYS command. The system must be in a restricted state for this.

Running the SAVSYS command not only performs a save of SLIC, but also saves base i5/OS, user profiles, and configuration data. The recommended frequency for SAVSYS depends on the changes that were performed on SLIC, i5/OS, configuration, or user profiles.

For SLIC and i5/OS, it depends on whether any PTFs have been applied since the last time SAVSYS was performed. If you have applied many PTFs, including cumulative PTF package or a group PTF, a new SAVSYS is recommended.

Today, many customers perform a SAVSYS once a month for SLIC, and one a week for configuration and user profiles. However, if there are numerous daily changes in user profiles, we recommend that user profiles be backed up on a daily basis.

In the scenario described here, a SAVSYS is performed from the command line. For the SAVSYS in this scenario, five volumes were created, with a maximum size of 1 GB each. For a small V5R4 system, about 4 GB is required for SAVSYS. However, in order to be sure, five volumes were created. The size required on your system may differ, for example, due to a large number of user profiles.

The physical tape device used in this example is an old type Quarter Inch Cartridge (QIC) tape device. The used tape volume is a QIC4DC cartridge with a maximum size of 8 GB. The only supported block size for this medium is 32 K, which implies that the virtual volumes should be created with a 32 K-compatible density.

If you have a newer-type cartridge device use a larger block size, since this performs better. For compatibility of block sizes, check the block size chart in Appendix A, “Block sizes” on page 457.

### 4.3.1 Preparing for SAVSYS

To perform a SAVSYS, follow the steps outlined here to set up the environment for virtual tape as used in this scenario. If you have already set up one or more items, you can skip that step.

- ▶ To create the virtual device and vary it, enter the following commands:

```
CRTDEVTAP DEVD(TAPVRT01) RSRNAME(*VRT)
VRYCFG CFGOBJ(TAPVRT01) CFGTYPE(*DEV) STATUS(*ON)
```

- ▶ To create the image catalog, enter the following command:

```
CRTIMGCLG IMGCLG(CATALOG01) DIR('/MyCatalogDirectory01') TYPE(*TAP)
```

- ▶ To add the image catalog entries, enter the commands shown in Example 4-1.

*Example 4-1 Add image catalog entries*

---

```
ADDIMGCLGE IMGCLG(CATALOG01) FROMFILE(*NEW) TOFILE(VIR001) VOLNAM(VIR001)
DENSITY(*VRT32K)
ADDIMGCLGE IMGCLG(CATALOG01) FROMFILE(*NEW) TOFILE(VIR002) VOLNAM(VIR002)
DENSITY(*VRT32K)
ADDIMGCLGE IMGCLG(CATALOG01) FROMFILE(*NEW) TOFILE(VIR003) VOLNAM(VIR003)
DENSITY(*VRT32K)
ADDIMGCLGE IMGCLG(CATALOG01) FROMFILE(*NEW) TOFILE(VIR004) VOLNAM(VIR004)
DENSITY(*VRT32K)
```

```
ADDIMGCLGE IMGCLG(CATALOG01) FROMFILE(*NEW) TOFILE(VIR005) VOLNAM(VIR005)
DENSITY(*VRT32K)
```

---

- ▶ To load the image catalog, enter the following command:

```
LODIMGCLG IMGCLG(CATALOG01) DEV(TAPVRT01)
```

### 4.3.2 Performing SAVSYS

After the virtual tape environment is created, you can run the SAVSYS command. Perform the following tasks:

1. Sign into the console (if you have not already done so).
2. Close all applications before bringing the system to restricted state.  
Remember that SAVSYS requires the system to be in a restricted state, and we have not outlined all the steps necessary to end your applications and vary the devices.
3. When you are ready to bring the system to restricted state to perform SAVSYS, type the following command:

```
ENDSBS SBS(*ALL) OPYION(*IMMED)
```

Then press Enter.

4. Wait until the system is in restricted state. A message (CPF0968) stating System ended to restricted condition appears.
5. Enter the following command:

```
SAVSYS DEV(TAPVRT01)
```

Then press Enter. If your virtual tape device's name is different, use that name.

SAVSYS is now running, and will take about 15 to 20 minutes to be completed, depending on the number of user profiles.

In this scenario, it took 15 minutes on a model 270 with system processor feature 23F5, processor feature 2434, five disks, 6 GB of main storage, and using virtual tape in ASP2 (user ASP 1 disk).

Remember that virtual volumes with a density of \*VRT32K have been created. In this scenario, this is required, since the 32 K block size has to be compatible with the QIC type cartridge used in this scenario.

If you are new to virtual tape and are curious about what is on the volumes now, display the contents of the virtual tape volumes by performing the following tasks:

1. Enter the following command:

```
WRKIMGCLG
```

Then press Enter. The screen shown in Figure 4-41 appears.

```
Work with Image Catalog Entries

Catalog . . . : CATALOG01          Status . . . : Ready
Type . . . . : Tape              Device . . . : TAPVRT01
Directory . . : /imgclg/tape/MyCatalogDirectory01

System: RCHAS08

Type options, press Enter.
1=Add  2=Change  4=Remove  6=Mount  8=Load  9=Unload
10=Initialize volume  11=Display  13=Dump  14=Duplicate

Opt  Index  Status    Volume Name  Density  Type  Write
      *AVAIL
      1  Mounted  VRT001    *VRT32K    *SL     No
      2  Loaded  VRT002    *VRT32K    *SL     No
      3  Mounted  VRT003    *VRT32K    *SL     No
      4  Loaded  VRT004    *VRT32K    *SL     No
      5  Loaded  VRT005    *VRT32K    *SL     No
```

Figure 4-41 WRKIMGCLG

2. Press F11 to see which volumes contain data. This displays the window shown in Figure 4-42.

```
Work with Image Catalog Entries

Catalog . . . : CATALOG01          Status . . . : Ready
Type . . . . : Tape              Device . . . : TAPVRT06
Directory . . : /imgclg/tape/MyCatalogDirectory01

System: RCHAS08

Type options, press Enter.
1=Add  2=Change  4=Remove  6=Mount  8=Load  9=Unload
10=Initialize volume  11=Display  13=Dump  14=Duplicate

Opt  Index  Status    Volume Name  Maximum  Percent
      *AVAIL
      1  Mounted  VRT001    1000        99.8
      2  Loaded  VRT002    1000        99.8
      3  Loaded  VRT003    1000        99.8
      4  Loaded  VRT004    1000        43.0
      5  Loaded  VRT005    1000         .1
```

Figure 4-42 Work with image catalog entries

Figure 4-42 shows that volumes VRT001, VRT002, VRT003, and VRT004 contain data. This is because the job log of the job in which SAVSYS was performed also reports the volumes that are used.

3. To display the contents of a volume, specify 11 in the Opt column in front of the volume you want to display, and press Enter.

The window displayed in Figure 4-43 is shown.

```
Display Tape Volume Information

Device . . . . . : TAPVRT06      Volume ID . . . . . : VRT001
Owner ID . . . . . :              Density . . . . . : *VRT32K
Type . . . . . : *SL             Code . . . . . : *EBCDIC

Data file label . . . . . : QFILEIML
File sequence . . . . . : 0000000001

Record format . . . . . : U
Block attribute . . . . . :
Record length . . . . . : 00000
Block length . . . . . : 032760
File length . . . . . : 0000006501
Buffer offset . . . . . :
Control character . . . . . :

More...
```

Figure 4-43 Display tape from the work with image catalog entries screen

4. To view the next labels, press Enter.
5. To see all the labels per volume, enter the following command and press Enter:

```
DSPTAP DEV(TAPVRT01) VOL(VRT001) LABEL(*ALL) DATA(*LABELS) OUTPUT(*PRINT)
```

This generates a spooled file QPTAPDSP. Figure 4-44 on page 179 shows the labels on the first volume VRT001.

5722SS1 V5R4M0 060210		TAPE VOLUME INFORMATION				VRT001	RCHAS08	
Device . . . . .	: TAPVRT06	Volume . . . . .	: VRT001					
Owner ID . . . . .	:	Density . . . . .	: *VRT32K					
Type . . . . .	: *SL	Code . . . . .	: *EBCDIC					
		Record						
	File	Block	Recg	Record	Block	File	Mvol	Mvol
Data File Label	Sequence	Format	Tech	Length	Length	Length	Ind	Sequence
QFILEIML	0000000001	*U		00000	032760	0000006501		0000000001
QV5R4M0L00.L2924	0000000002	*U		00000	032760	0000000001		0000000001
QFILESCR	0000000003	*U		00000	032760	0000000216		0000000001
QIAM400	0000000004	*U		00000	032760	0000000001		0000000001
QFILELDS	0000000005	*U		00000	032760	0000000019		0000000001
QFILEMCD	0000000006	*U		00000	032760	0000030214	CONT	0000000001

Figure 4-44 Display tape volume information of VRT001

Following is a brief description of the labels related to SAVSYS:

- QFILEIML  
Contains the initial microcode load used when IPL from tape is selected (D-type IPL).
- Q5R4M0L00.L2924  
Language feature code identification file for installation. Label = QVxRxMxLxx.Lxxxx, where VxRxMxLxx is the version, release and modification level, and Lxxxx is the current system language.
- QFILESCR  
Installation file for Licensed Internal Code that contains SLIC installation screens.
- QIAM400  
Contains the personality of the system to indicate that this is an iSeries system.
- QFILELDS  
Contains LIC, including DST, security data.
- QFILEMCD  
Installation file for Licensed Internal Code or microcode space.

6. To check the tape labels of the second volume, enter the following command:

```
DSPTAP DEV(TAPVRT01) VOL(VRT002) LABEL(*ALL) DATA(*LABELS) OUTPUT(*PRINT)
```

Then press Enter. Figure 4-45 on page 180 shows the contents of the second spoolfile, which displays the labels of the second volume VRT002.

5722SS1 V5R4M0 060210				TAPE VOLUME INFORMATION			VRT002	RCHAS08
Device . . . . .	:	TAPVRT06		Volume . . . . .	:	VRT002		
Owner ID . . . . .	:			Density . . . . .	:	*VRT32K		
Type . . . . .	:	*SL		Code . . . . .	:	*EBCDIC		
			Record					
	File	Block	Recg	Record	Block	File	Mvol	
Data File Label	Sequence	Format	Tech	Length	Length	Length	Ind	
							Sequence	
QFILECMD	0000000006	*U		00000	032760	0000004177	LAST	0000000002
QV5R4M0L00.L2924	0000000007	*U		00000	032760	0000000001		0000000002
QFILEIPL	0000000008	*U		00000	032760	0000000027		0000000002
QFILEIN	0000000009	*U		00000	032760	0000000061		0000000002
Q5722SS1540M.0001	0000000010	*U		00000	032760	0000002704		0000000002
Q5722SS1540M.0002	0000000011	*U		00000	032760	0000004113		0000000002
Q5722SS1540M.0003	0000000012	*U		00000	032760	0000002374		0000000002
Q5722SS1540M.0004	0000000013	*U		00000	032760	0000006042		0000000002
Q5722SS1540M.0005	0000000014	*U		00000	032760	0000002986		0000000002
Q5722SS1540M.0006	0000000015	*U		00000	032760	0000002440		0000000002
Q5722SS1540M.0007	0000000016	*U		00000	032760	0000002656		0000000002
Q5722SS1540M.0008	0000000017	*U		00000	032760	0000004319		0000000002
Q5722SS1540M.0009	0000000018	*U		00000	032760	0000004566	CONT	0000000002

Figure 4-45 Display tape volume information of VRT002

Following is a brief description of the tape labels on the second volumes:

- QFILECMD  
Installation file for Licensed Internal Code or microcode space.
- QV5R4M0L00.L2924  
Language feature code identification file for installation of label #2.
- QFILEIPL  
Contains all the necessary templates to load the initial installation program. It also contains the QSYS user profile.
- QFILEIN  
Contains all the installation modules. For automatic installation, it contains the automatic installation profile QLPAUTO.
- QppppSS1vrmM.00x  
pppp represents the current i5/OS product identifier, and vrm the version, release, and modification. These files contain programs and objects that are not language-sensitive and internal objects.

7. To check the tape labels of the third volume, enter the following command:

```
DSPTAP DEV(TAPVRT01) VOL(VRT003) LABEL(*ALL) DATA(*LABELS) OUTPUT(*PRINT)
```

Then press Enter. Figure 4-46 shows the contents of the third spoolfile, which displays the labels of volume VRT003.

5722SS1 V5R4M0 060210			TAPE VOLUME INFORMATION				VRT003	RCHAS08
Device . . . . . :	TAPVRT06		Volume . . . . . :	VRT003				
Owner ID . . . . . :			Density . . . . . :	*VRT32K				
Type . . . . . :	*SL		Code . . . . . :	*EBCDIC				
		Record						
	File	Block	Recg	Record	Block	File	Mvol	Mvol
Data File Label	Sequence	Format	Tech	Length	Length	Length	Ind	Sequence
Q5722SS1540M.0009	0000000018	*U		00000	032760	0000000072	LAST	0000000003
Q5722SS1540M.0010	0000000019	*U		00000	032760	0000003486		0000000003
Q5722SS1540M.0011	0000000020	*U		00000	032760	0000003902		0000000003
Q5722SS1540M.0012	0000000021	*U		00000	032760	0000002847		0000000003
Q5722SS1540M.0013	0000000022	*U		00000	032760	0000005462		0000000003
Q5722SS1540M.0014	0000000023	*U		00000	032760	0000015055		0000000003
Q5722SS1540M.0015	0000000024	*U		00000	032760	0000005645	CONT	0000000003

Figure 4-46 Display tape volume information of VRT003

The tape labels on this volume are the same as described under volume VRT002.

- To check the tape labels of the fourth volume, enter the following command:  
DSPTAP DEV(TAPVRT03) VOL(VRT004) LABEL(\*ALL) DATA(\*LABELS) OUTPUT(\*PRINT)  
Then press Enter. The last spoolfile is shown in Figure 4-47 on page 182.

5722SS1 V5R4M0 060210				TAPE VOLUME INFORMATION			VRT004	RCHAS08
Device . . . . .	:	TAPVRT06		Volume . . . . .	:	VRT004		
Owner ID . . . . .	:			Density . . . . .	:	*VRT32K		
Type . . . . .	:	*SL		Code . . . . .	:	*EBCDIC		
			Record					
	File	Block	Recg	Record	Block	File	Mvol	
Data File Label	Sequence	Format	Tech	Length	Length	Length	Ind	
							Sequence	
Q5722SS1540M.0015	0000000024	*U		00000	032760	0000006763	LAST	0000000004
Q5722SS1540M.0016	0000000025	*U		00000	032760	0000001076		0000000004
Q5722SS1540240001	0000000026	*U		00000	032760	0000000026		0000000004
Q5722SS1540240002	0000000027	*U		00000	032760	0000000381		0000000004
Q5722SS1540240003	0000000028	*U		00000	032760	0000000373		0000000004
Q5722SS1540240004	0000000029	*U		00000	032760	0000000359		0000000004
Q5722SS1540240005	0000000030	*U		00000	032760	0000001493		0000000004
Q5722SS1540240006	0000000031	*U		00000	032760	0000001479		0000000004
Q5722SS1540240007	0000000032	*U		00000	032760	0000000720		0000000004
Q5722SS1540240090	0000000033	*U		00000	032760	0000001316		0000000004
Q5722SS1540M.0090	0000000034	*U		00000	032760	0000001135		0000000004
QFILEUPR	0000000035	*U		00000	032760	0000000554		0000000004
QFILEIIOC	0000000036	*U		00000	032760	0000000036		0000000004

Figure 4-47 Display tape volume information of VRT004

In addition to the labels previously described, VRT004 contains two additional labels. Following is a brief description of these two labels:

- QFILEUPR  
This contains user data.
- QFILEIIOC  
This contains configuration data.

### 4.3.3 Duplicating virtual volumes

The SAVSYS backup data continues to remain in the virtual volumes. The virtual volumes should now be duplicated to physical media. For other data (for example, user data), you can decide to keep a copy on the system, but for SLIC and base i5/OS, it is not possible to install from virtual volumes, as described in 2.6.1, “Installing i5/OS and related software” on page 26.

For the physical tape device in this scenario, we used TAP01, which is a QIC2GB-compatible device. The virtual tape device to be specified in the TODEV parameter in the DUPTAP command is the virtual tape device associated with the image catalog in which the virtual volumes reside.

To duplicate the virtual volumes to physical volumes, enter the following command:

```
DUPTAP FROMDEV(TAPVRT01) TODEV(TAP01) FROMVOL(*MOUNTED) TOVOL(*MOUNTED)
```

Then press Enter. After duplication is complete, you can review the joblog shown in Figure 4-48 on page 184.

```

*NONE      Request          12/12/05 18:08:09.220056 QPTCHECK      *N QUICMD QSYS
0461
                Message . . . . : -DUPTAP FROMDEV(TAPVRT01) TODEV(TAP01)
FROMVOL(*MOUNTED)
                                TOVOL(*MOUNTED)
EXPDATE(*FROMFILE)
CPI6742    Information      00 12/12/05 18:35:49.984160 QTADUP QSYS 1C2C QUICMD QSYS
048D
                                Message . . . . : Volume VRT001 duplication
complete.
                Cause . . . . . : Some or all files from volume VRT001 on device
TAPVRT01
                                were successfully duplicated to device
TAP01.
CPI6742    Information      00 12/12/05 19:01:38.972312 QTADUP QSYS 1C2C QUICMD QSYS
048D
                                Message . . . . : Volume VRT002 duplication
complete.
                Cause . . . . . : Some or all files from volume VRT002 on device
TAPVRT01
                                were successfully duplicated to device
TAP01.
CPI6742    Information      00 12/12/05 19:31:47.560184 QTADUP QSYS 1C2C QUICMD QSYS
048D
                                Message . . . . : Volume VRT003 duplication
complete.
                Cause . . . . . : Some or all files from volume VRT003 on device
TAPVRT01
                                were successfully duplicated to device
TAP01.
CPI6742    Information      00 12/12/05 19:45:43.328472 QTADUP QSYS 1C2C QUICMD QSYS
048D
                                Message . . . . : Volume VRT004 duplication
complete.
                Cause . . . . . : Some or all files from volume VRT004 on device
TAPVRT01
                                were successfully duplicated to device
TAP01.
CPC6775    Completion       00 12/12/05 19:45:43.355992 QTADUP QSYS 1C2C QUICMD QSYS
048D
                                Message . . . . : Tape duplication completed
successfully.
                Cause . . . . . : 36 files were successfully duplicated from device
TAPVRT01
                                to device TAP01.

```

Figure 4-48 Joblog of DUPTAP from virtual to physical tape

According to the joblog, 36 files are duplicated. This matches the total amount of sequences on the four virtual volumes.

To be sure, you can print the contents of the physical tape using the following command:

```
DSPTAP DEV(TAP01) VOL(VOL001) LABEL(*ALL) DATA(*LABELS) OUTPUT(*PRINT)
```

Figure 4-49 on page 186 shows printout of the spooled file of the tape labels on the physical volume.

Data File Label	Record		Recg Tech	Record Length	Block Length	File Length	Mvol Ind	Mvol Sequence
	File Sequence	Block Format						
QFILEIML	0000000001	*U		00000	032760	0000006501		0000000001
QV5R4MOL00.L2924	0000000002	*U		00000	032760	0000000001		0000000001
QFILEESCR	0000000003	*U		00000	032760	0000000216		0000000001
QIAM400	0000000004	*U		00000	032760	0000000001		0000000001
QFILELDS	0000000005	*U		00000	032760	0000000019		0000000001
QFILEMCD	0000000006	*U		00000	032760	0000034391		0000000001
QV5R4MOL00.L2924	0000000007	*U		00000	032760	0000000001		0000000001
QFILEIPL	0000000008	*U		00000	032760	0000000027		0000000001
QFILEIN	0000000009	*U		00000	032760	0000000061		0000000001
Q5722SS1540M.0001	0000000010	*U		00000	032760	0000002704		0000000001
Q5722SS1540M.0002	0000000011	*U		00000	032760	0000004113		0000000001
Q5722SS1540M.0003	0000000012	*U		00000	032760	0000002374		0000000001
Q5722SS1540M.0004	0000000013	*U		00000	032760	0000006042		0000000001
Q5722SS1540M.0005	0000000014	*U		00000	032760	0000002986		0000000001
Q5722SS1540M.0006	0000000015	*U		00000	032760	0000002440		0000000001
Q5722SS1540M.0007	0000000016	*U		00000	032760	0000002656		0000000001
Q5722SS1540M.0008	0000000017	*U		00000	032760	0000004319		0000000001
Q5722SS1540M.0009	0000000018	*U		00000	032760	0000004638		0000000001
Q5722SS1540M.0010	0000000019	*U		00000	032760	0000003486		0000000001
Q5722SS1540M.0011	0000000020	*U		00000	032760	0000003902		0000000001
Q5722SS1540M.0012	0000000021	*U		00000	032760	0000002847		0000000001
Q5722SS1540M.0013	0000000022	*U		00000	032760	0000005462		0000000001
Q5722SS1540M.0014	0000000023	*U		00000	032760	0000015055		0000000001
Q5722SS1540M.0015	0000000024	*U		00000	032760	0000012408		0000000001
Q5722SS1540M.0016	0000000025	*U		00000	032760	0000001076		0000000001
Q5722SS1540240001	0000000026	*U		00000	032760	0000000026		0000000001
Q5722SS1540240002	0000000027	*U		00000	032760	0000000381		0000000001
Q5722SS1540240003	0000000028	*U		00000	032760	0000000373		0000000001
Q5722SS1540240004	0000000029	*U		00000	032760	0000000359		0000000001
Q5722SS1540240005	0000000030	*U		00000	032760	0000001493		0000000001
Q5722SS1540240006	0000000031	*U		00000	032760	0000001479		0000000001
Q5722SS1540240007	0000000032	*U		00000	032760	0000000720		0000000001
Q5722SS1540240090	0000000033	*U		00000	032760	0000001316		0000000001
Q5722SS1540M.0090	0000000034	*U		00000	032760	0000001135		0000000001
QFILEUPR	0000000035	*U		00000	032760	0000000554		0000000001
QFILEIOC	0000000036	*U		00000	032760	0000000036		0000000001

Figure 4-49 DSPTAP OUTPUT(\*PRINT) of the physical volume

SAVSYS is now on the physical volume, and you can remove the virtual volumes by removing the image catalog entries.

Perform the following tasks:

1. To remove the image catalog entries, enter the following command:

WRKIMGCLG

Then press Enter.

2. Type 9 in front of the image catalog you used (CATALOG01) and press Enter.
3. Type 4 in front of each volume you want to delete and press **Enter**.
4. Press F3 to exit the Work with Image Catalogs Entries window.

The virtual volumes used for SAVSYS are now removed and the space is freed.

### 4.3.4 Summary

Table 4-1 compares the total time taken by SAVSYS performed using virtual tape and SAVSYS performed directly to physical tape, using the same physical tape drive as that used for duplication.

Table 4-1 Comparison of SAVSYS to virtual tape and SAVSYS to physical tape

	SAVSYS to virtual tape	SAVSYS to physical tape
Restricted state time (in minutes)	15	101
Duplication time (in minutes)	98	NA
Total time (in minutes)	113	101

**Note:** The actual restricted state time is 15 minutes, as shown in Table 4-1.

Note the following conclusions:

- ▶ In this scenario, from a performance point of view, there is not much difference. However, the major benefit is that the restricted state time decreases significantly with virtual tape.
- ▶ In an i5 environment with multiple partitions, there are configurations with only one single physical tape drive shared with other partitions. In such a situation, the tape drive is scheduled to move from one partition to the other.

Although this way of scheduling is very simple, on releases prior to V5R4, you still have to have a physical drive attached to the partition at save time. With virtual tape, you can run the save at the same time.

- ▶ Operator intervention is unnecessary.

When using physical tape, there are four possible situations when operator intervention is required:

- Wrong type tape cartridge is inserted.

- Wrong volume ID inserted.
- Next volume has to be mounted when the first volume is full and reaches the end of volume.
- Any hardware on tape device or media error.

**Note:** Operator intervention can decrease the restricted save state time.



## Saving Domino with BRMS and virtual tape

In this chapter we describe how to set up a backup for Domino, using virtual tapes. We also look at the logs that are produced, and at the process involved in restoring a mail file.

The information provided in this chapter is based on the assumption that you have an adequate understanding of the BRMS application working from i5 Navigator. For more information about this topic, refer to the IBM Redbook titled *Domino 6 for iSeries Best Practices Guide*, SG24-6937.

For more information about fine-tuning BRMS backups, refer to the IBM publication *Backup Recovery and Media Services*, SC41-5345. This can be accessed on the Web at:

<http://www.elink.ibm.link.ibm.com/public/applications/publications/cgibin/pbi.cgi?PAG=C11&SSN=06DZI0007040138732&TRL=TXT&WRD=&PBL=SC41-5345-00&LST=ALL&RPP=10&BTN%3DSRH.x=6&BTN%3DSRH.y=11>

Before you back up Domino data using BRMS, visit the following Web site:

<http://www-03.ibm.com/servers/eserver/iseries/service/brms/domino.html>

## 5.1 Creating the image catalog

This scenario, which was set up using i5 Navigator as a graphical interface, appears automatically when working with Domino. To create the image dialog using i5 Navigator, perform the following tasks:

1. Start i5 Navigator, sign in, and go to Image catalogs, by selecting **Configuration and Service** → **Hardware** → **Tape devices**.
2. Right-click **Tape Image catalogs** and select **Create Image catalog**, as shown in Figure 5-1.

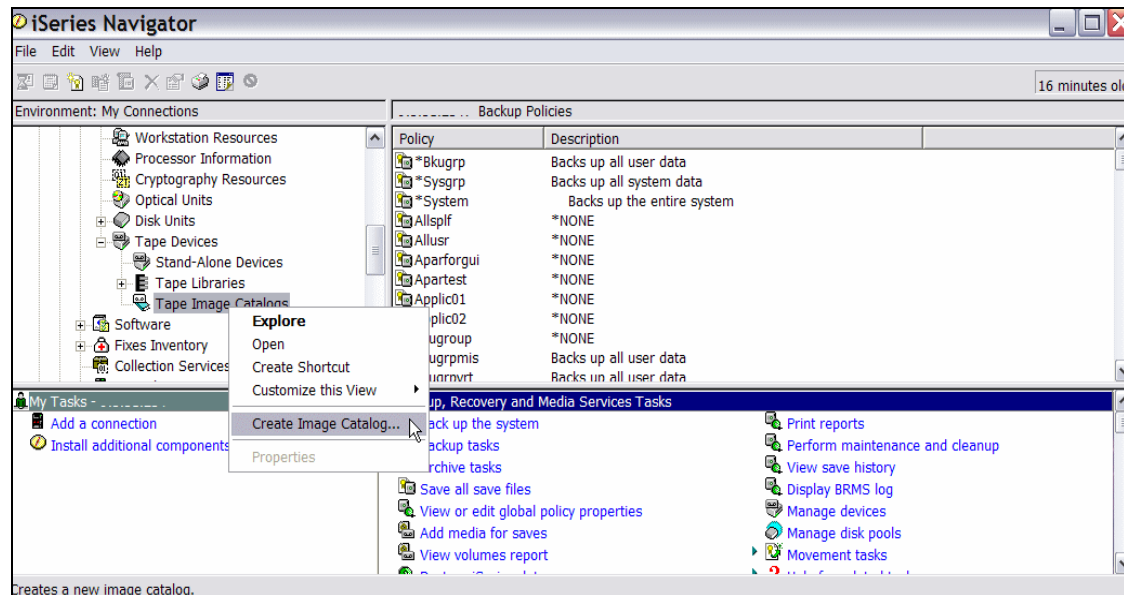

Figure 5-1 Create new image catalog

3. In the window that appears, as shown in Figure 5-2 on page 191, input the following values, and click **OK**:
  - a. Input the image Catalog name (in this scenario, it is dominovrt).
  - b. Input Catalog description (in this scenario, it is Image catalog for Domino save to virtual tape).
  - c. Input the desired Directory path (in this scenario, it is /tmp/vrt).If the directory does not exist, select **Yes** against Create Directory.

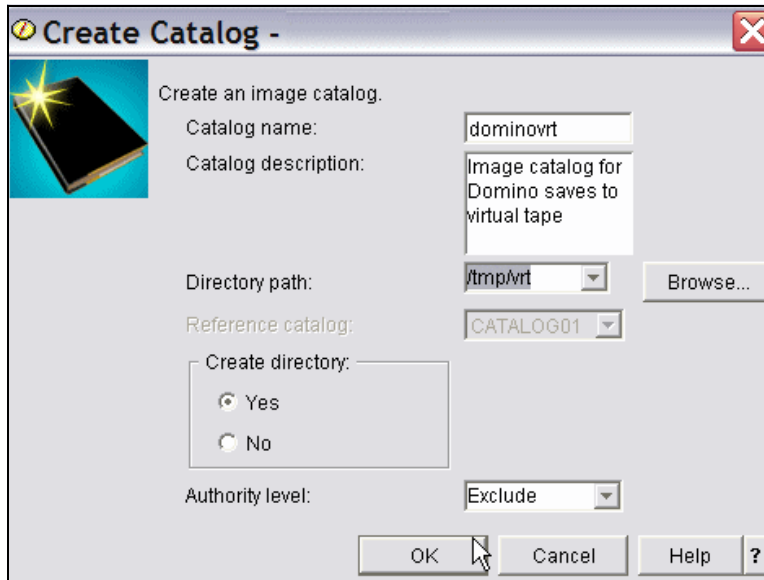

Figure 5-2 Create image catalog

An image catalog is created. (Press F5 if it does not show up automatically.)

4. Right-click the image catalog and select **Add volume**, as shown in Figure 5-3 on page 192.

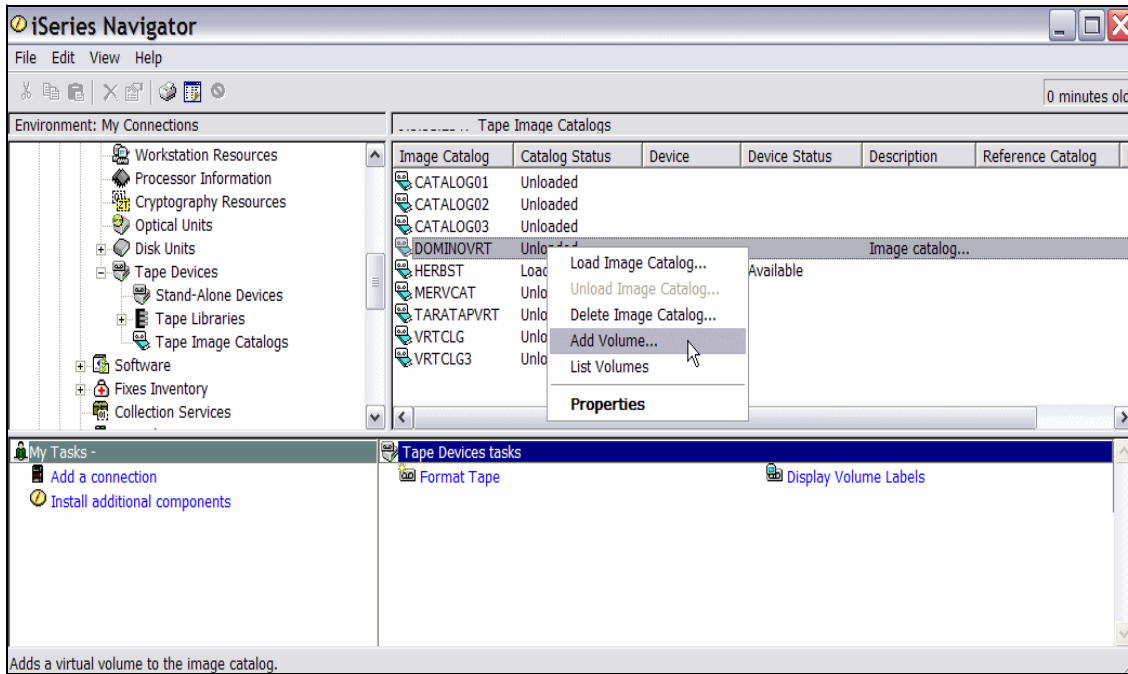

Figure 5-3 Domino with BRMS virtual tape, add volumes to image catalog

- The window shown in Figure 5-4 on page 193 displays. In the General tab, input a value for the field To tape image file with the volume name (in this scenario, it is dom001).

You may wonder why we are giving dedicated names to virtual volumes. Normally, tape volumes are given general names so that they can be used for anything. However, you can have a specific set of volumes for a single purpose.

Fill in a description if this volume is to be used for a specific purpose.

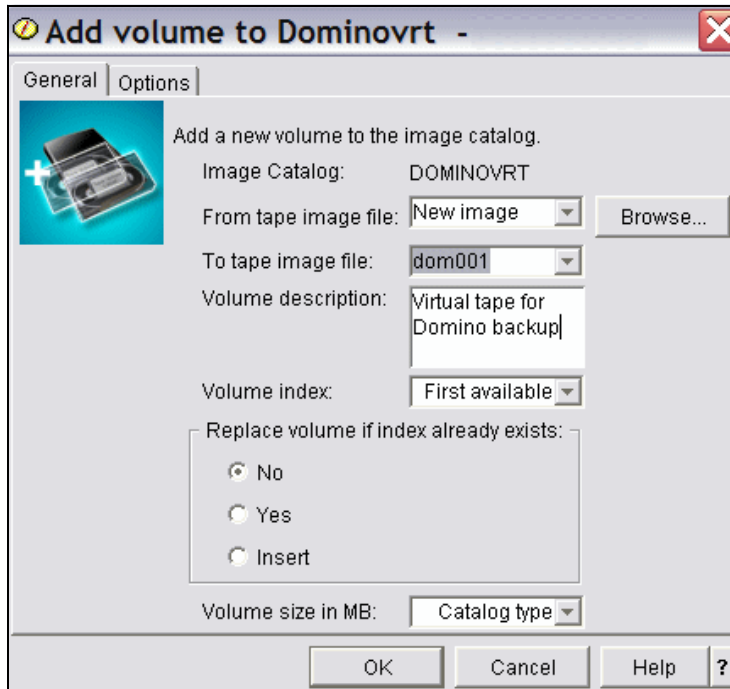

Figure 5-4 Domino with BRMS virtual tape, add volumes to image catalog - General tab

6. Click the **Options** tab, shown in Figure 5-4.

The window shown in Figure 5-5 on page 194 displays. To avoid confusion, use the same name for the volume (the To tape image file) that you input under the General tab shown in Figure 5-4 (in this scenario, it is dom001).

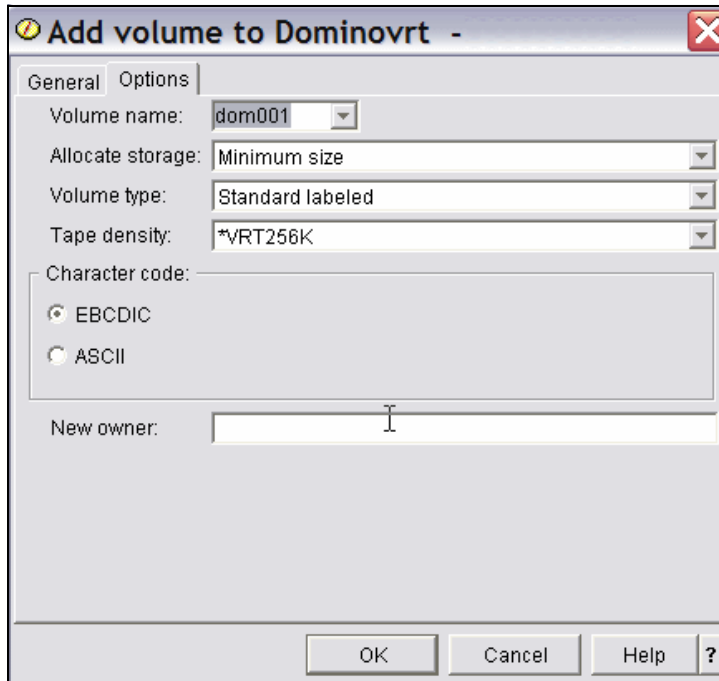

Figure 5-5 Domino with BRMS virtual tape, add volumes to image catalog - Options tab

Repeat the same procedure for the other volumes you want to add. In this scenario, add dom002 and dom003, as well.

7. After adding other volumes, list the volumes to verify that everything is in order by right-clicking the image catalog and selecting **List volumes**, as shown in Figure 5-6 on page 195.

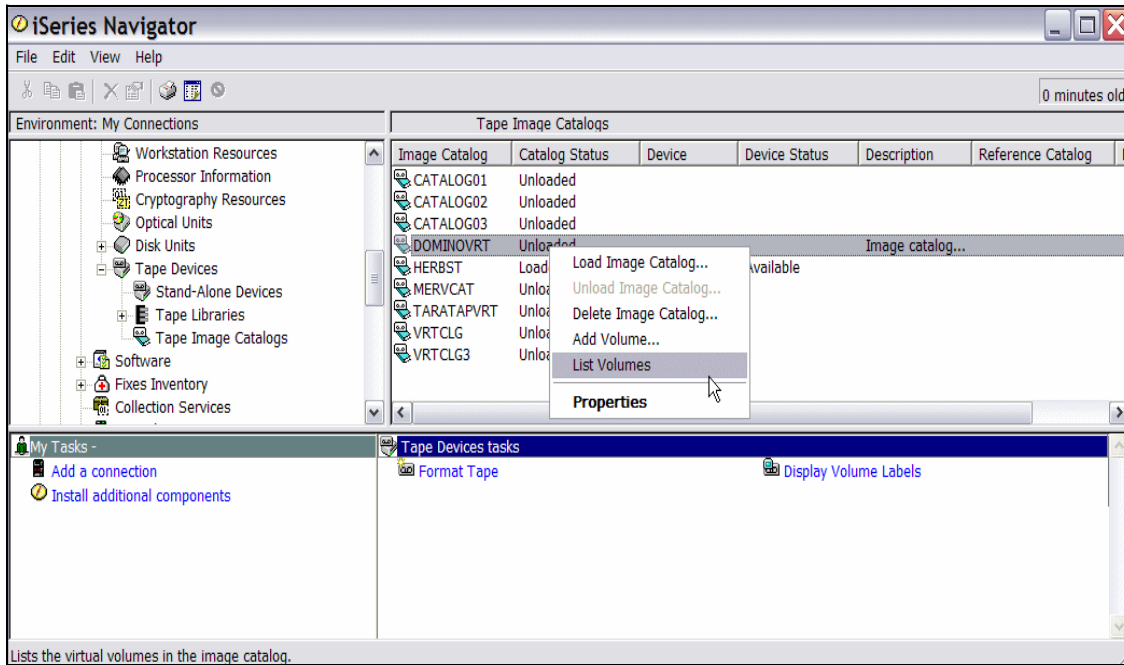

Figure 5-6 Domino with BRMS virtual tape, list volumes in image catalog

The volume list displays, as shown in Figure 5-7 on page 196.

Index	Volume Name	Status	Type	Density	Write Protected	Percent Used	Maximum Size	File Name	Description
1	DOM001	Loaded	Standard labeled	*VRT25...	No	0,0	1 000	dom001	Virtual tape f...
2	DOM002	Loaded	Standard labeled	*VRT25...	No	0,0	1 000	dom002	Virtual tape f...
3	DOM003	Loaded	Standard labeled	*VRT25...	No	0,0	1 000	dom003	Virtual tape f...

Figure 5-7 Domino with BRMS virtual tape, image catalog volume list

8. In order for an image catalog to be operated, it has to be connected to a tape drive. Right-click the image catalog and select **Load Image catalog**, as shown in Figure 5-8 on page 197.

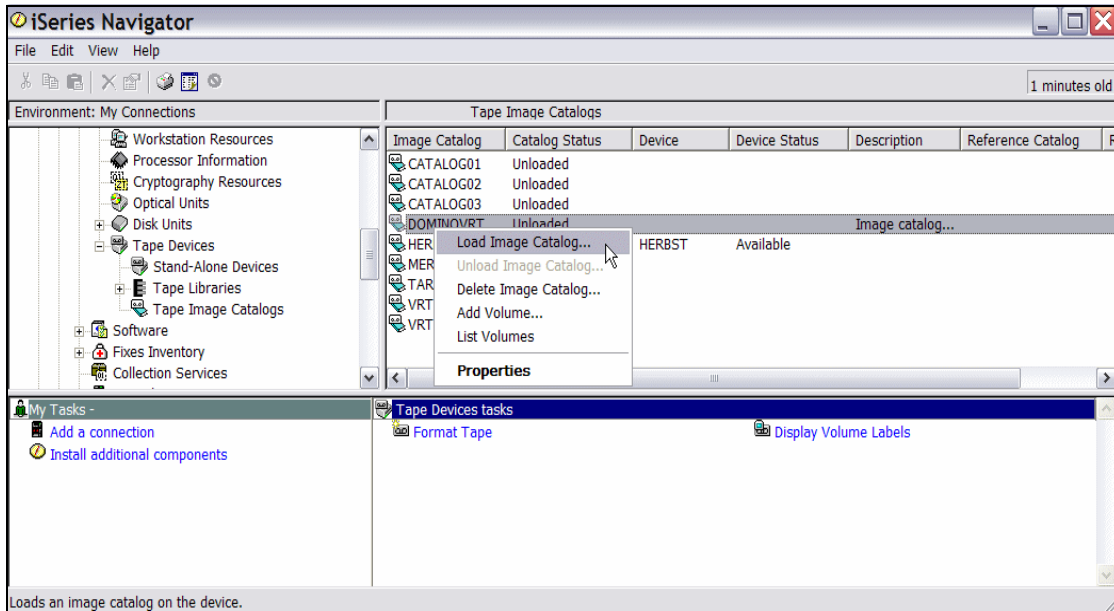

Figure 5-8 Domino with BRMS virtual tape - load image catalog

- In the window that appears, as shown in Figure 5-9, select a suitable tape drive that can handle the density, although all virtual tape drives can. In this scenario, select **tapvrt02**, and then click **OK**.

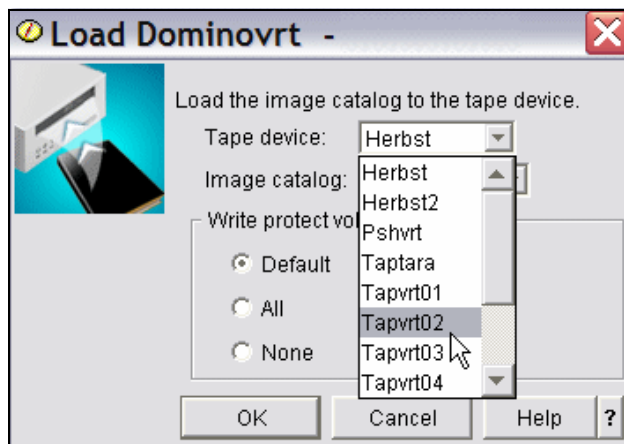
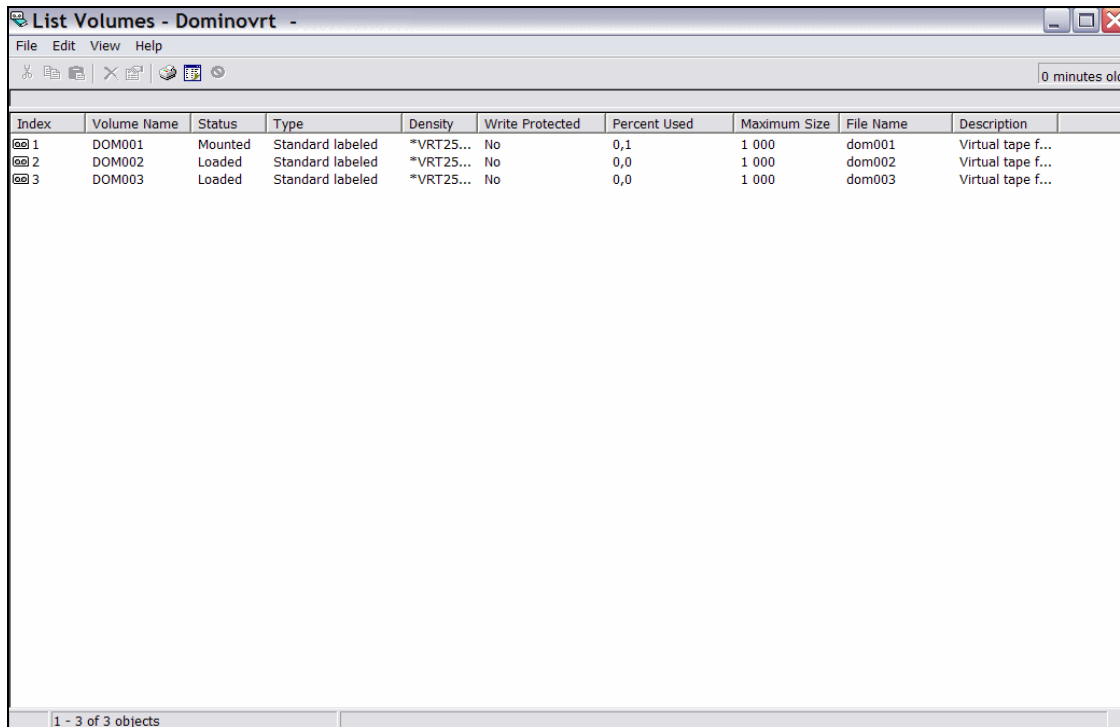

Figure 5-9 Domino with BRMS virtual tape - tape drive to load the image catalog

- Bring up the list of volumes by right-clicking the image catalog in the window shown in Figure 5-8, and selecting **List volumes**. This displays the list of

volumes. Figure 5-10 shows the list of volumes, with Volume 1 displaying a status of Mounted.



Index	Volume Name	Status	Type	Density	Write Protected	Percent Used	Maximum Size	File Name	Description
1	DOM001	Mounted	Standard labeled	*VRT25...	No	0,1	1 000	dom001	Virtual tape f...
2	DOM002	Loaded	Standard labeled	*VRT25...	No	0,0	1 000	dom002	Virtual tape f...
3	DOM003	Loaded	Standard labeled	*VRT25...	No	0,0	1 000	dom003	Virtual tape f...

Figure 5-10 Domino with BRMS virtual tape, list volumes in image catalog - refresh

You now have an image catalog and tape volumes. A mounted volume can be initialized or formatted. This can be done when adding volumes to BRMS.

**Note:** *Format* and *initialize* are the same. The Navigator uses the term “format”, while BRMS uses the term “initialize” in both 5250 emulation as well as in the Navigator plug-in.

11. To format, right-click the mounted volume and select **Format**, as shown in Figure 5-11 on page 199.

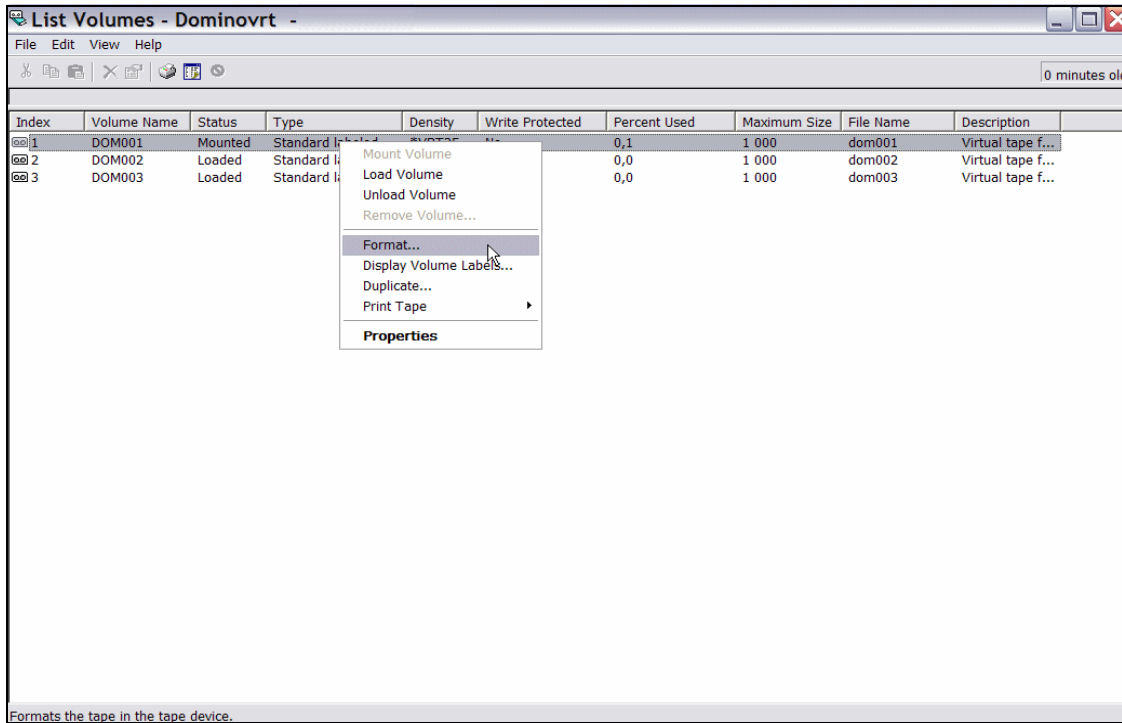

Figure 5-11 Domino with BRMS virtual tape, select volume for format

12. The Format panel has two tabs, General and Optional. All the fields in the General tab, shown in Figure 5-12 on page 200, are filled. However, you can make changes.

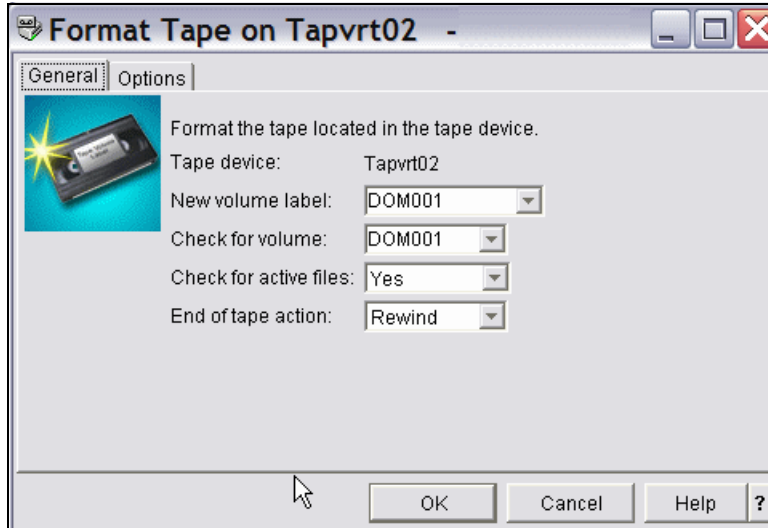

Figure 5-12 Domino with BRMS virtual tape, format options - General tab

All the fields in the Options tab are also filled, but you can make sure the density matches your physical tape drive that will later hold the copy of the virtual tape image, as shown in Figure 5-13. After making changes in the General and Options tabs, click **OK**.

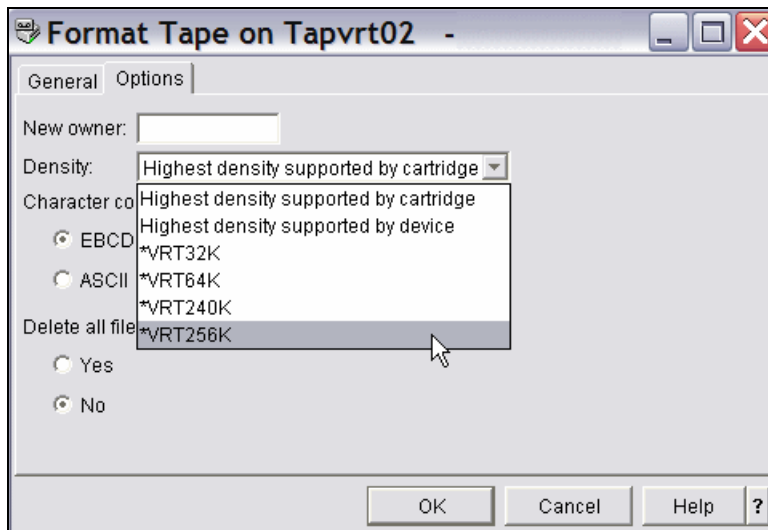

Figure 5-13 Domino with BRMS virtual tape, format options - Options tab

13. After the first volume is initialized, mount the next volume to be initialized, as described in step 10 on page 197, and shown in Figure 5-14.

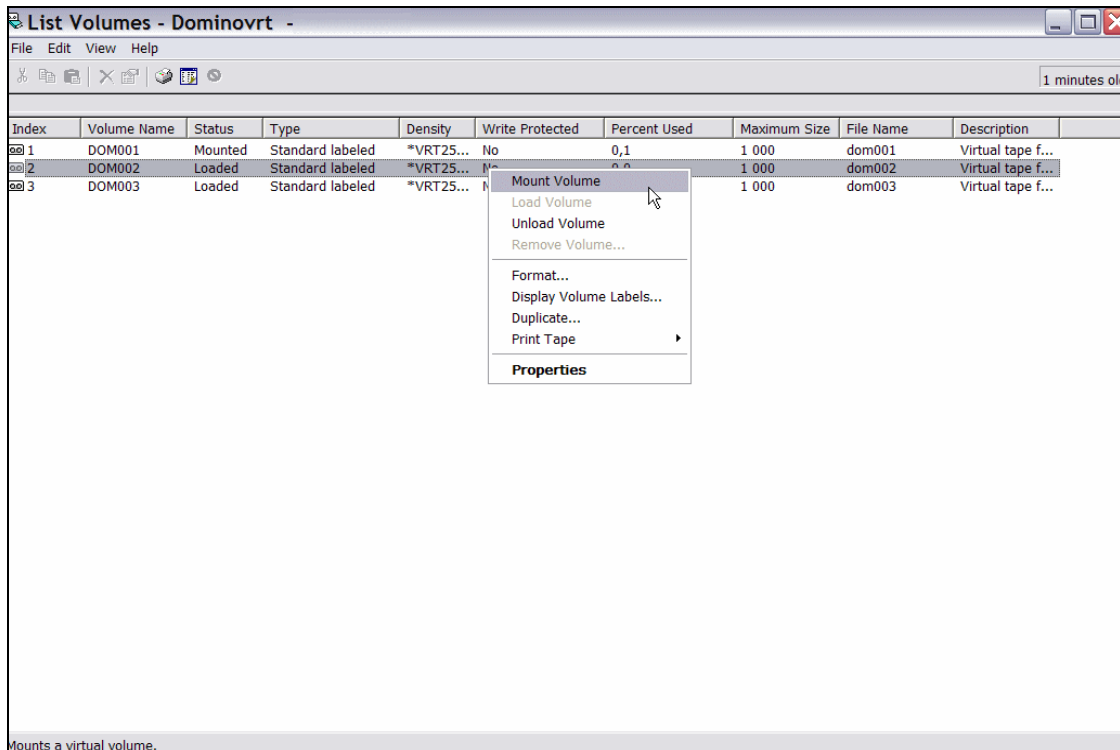

Figure 5-14 Domino with BRMS virtual tape, mount next volume

Repeat the steps until all the volumes are initialized.

This concludes the virtual setup action.

You now have the following:

- ▶ An image catalog.
- ▶ The image catalog contains virtual tape volumes.
- ▶ There are three initialized virtual tape volumes in the image catalog.
- ▶ The image catalog is loaded to a virtual tape drive.
- ▶ One of the tape volumes is mounted.
- ▶ The other two volumes are loaded or are ready to be mounted.

## 5.2 Creating a BRMS backup policy for Domino

The virtual tape environment is in place. You can now start with BRMS to set up the backup. To do this, create a backup policy. Along the way, create other definitions such as locations to make the backup work.

Before setting up definitions in BRMS, refer to the information available on the Web at:

<http://www-03.ibm.com/servers/eserver/series/service/brms/domino.html>

Following is a list of topics that are discussed at this Web site:

- ▶ Initialize BRMS
- ▶ Online backup
- ▶ Saved item catalog
- ▶ Disaster recovery planning
- ▶ Single database recovery
- ▶ Recommendations
- ▶ How it works
- ▶ Performance tuning
- ▶ Copying control groups
- ▶ Control group EXITs
- ▶ Incremental backups
- ▶ Recover an incremental backup
- ▶ High availability strategy
- ▶ Graphical User Interface

**Note:** The figures drawn from the Web site into this IBM Redbook are examples that were current at the time of writing, but may have changed since then. We recommend that you access the Web site directly to get the latest information.

Figure 5-15 on page 203 displays the “How it works” section of the Web site.

The screenshot shows the IBM BRMS website interface. At the top, there is a navigation bar with the IBM logo, a search box, and a 'Search' button. Below this is a secondary navigation bar with links for 'Home', 'Products', 'Services & solutions', 'Support & downloads', and 'My account'. The main content area has a breadcrumb trail: 'Servers > Midrange servers > BRMS >'. The page title is 'How it works'. The sidebar on the left contains a table of contents for 'Lotus Server Backups' with the following items:

Initialize BRMS
Online backup
Saved item catalog
Disaster recovery planning
Single database recovery
Recommendations
How it works
Performance tuning
Copying control groups
Control group EXITs
Incremental backups
Recover an incremental backup
High availability strategy

The main content area contains the following text:

**How it works**

In order to allow the collection of two backups into one entity, BRMS and the Lotus Servers use a concept in BRMS called a *package* (identified by the PKGID parameter on the SAVBRM command).

Lotus Servers will backup the databases while they are active, and upon completion will back up a secondary file and associate it with the first by using the package concept in BRMS. This secondary file contains all of the changes that occurred during the backup, such as transaction logs or journal-type information.

When a user requests recovery through BRMS of a Lotus Server database that was saved in this way, BRMS will call the Lotus Server through recovery exits to allow the Lotus Server to reapply any changes from the secondary file to the original database that was just restored, allowing the data to be in a coherent state.

Work with media information (WRKMEDIA) will hide the secondary pieces and show a 2 in the column that indicates how many pieces are associated with the saved item. Recovery reports, however, will show all of the pieces associated with each saved item.

Figure 5-15 Domino with BRMS, Internet home page - how it works

Once you understand how BRMS works in conjunction with Domino, it is easy to implement.

**Important:** We recommend that you study the information available on the Web site thoroughly before beginning this process.

To set up a backup for a Domino server named Domino02, perform the following tasks:

1. Log in to your i5 server using the Navigator (if you have not already done so).
2. Right-click **Backup policy** and select **New policy**, as shown in Figure 5-16.

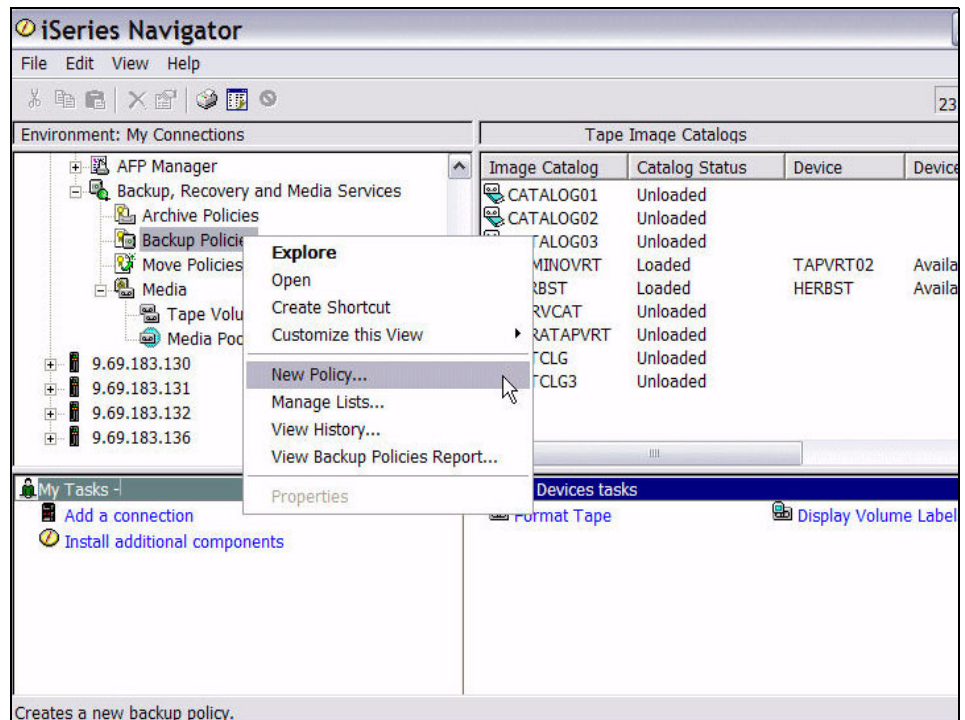
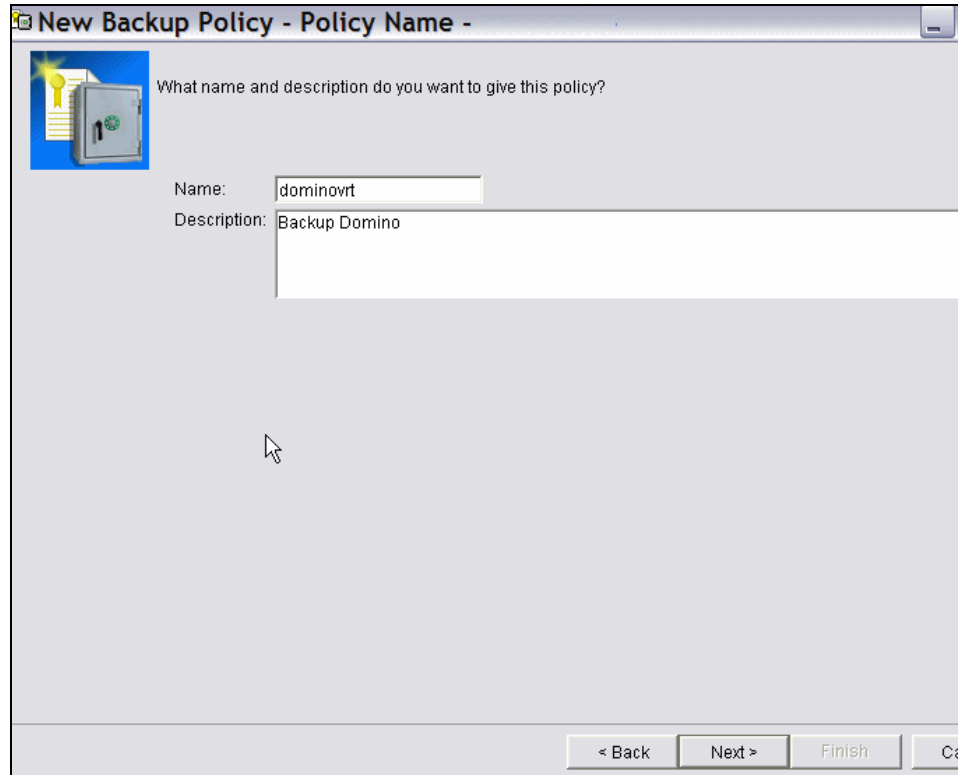

Figure 5-16 BRMS Backup policy, new

3. In the Welcome window that appears, click **Next**.

4. In the New Backup Policy - Policy Name window that appears, input the following information, as shown in Figure 5-17, and click **Next**:
  - Input the value for the backup policy Name field (in this scenario, the value is dominovrt).
  - Input an appropriate Description in the corresponding field.



New Backup Policy - Policy Name -

What name and description do you want to give this policy?

Name:

Description:

< Back   Next >   Finish   Ca

Figure 5-17 BRMS backup policy, policy name

5. In the Select a Save Strategy window shown in Figure 5-18, select **Save Lotus® server data or a customized set of objects**, and click **Next**.

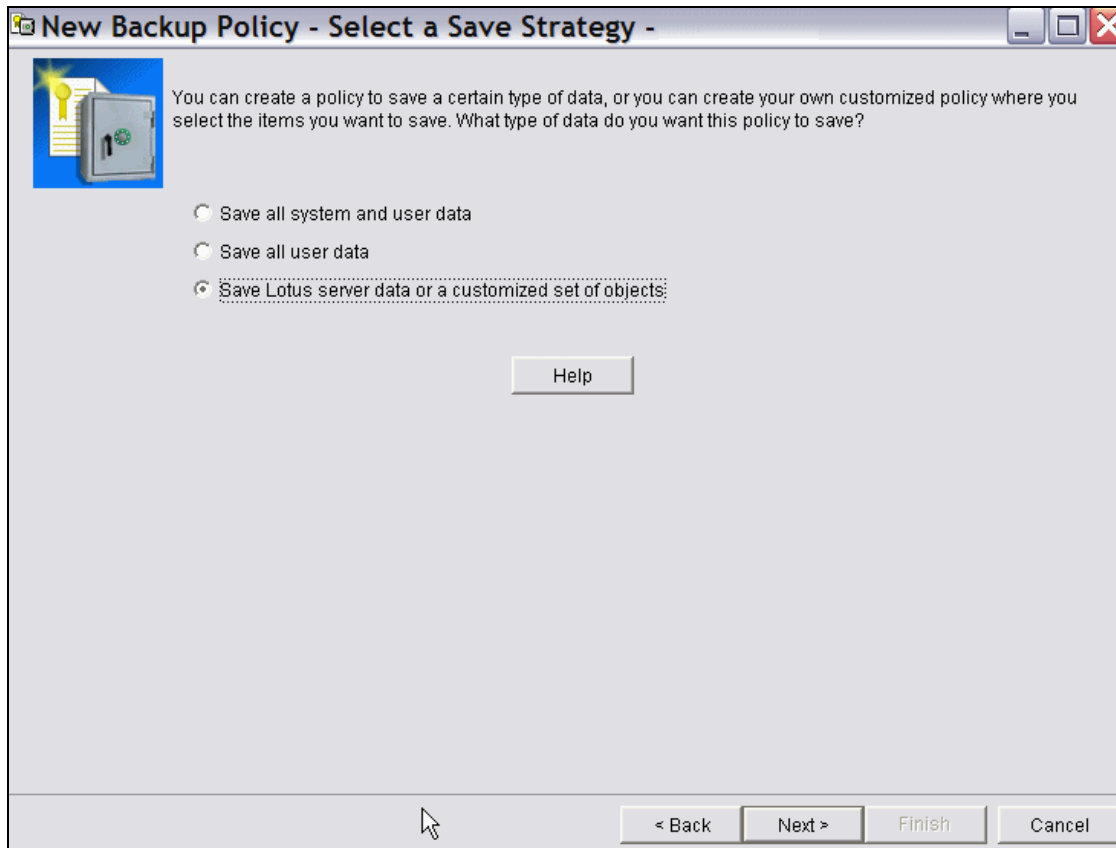

Figure 5-18 BRMS backup policy, save strategy

6. In the Customize IBM Data or User Data window shown in Figure 5-19 on page 207, select **User data**, and click **Next**.

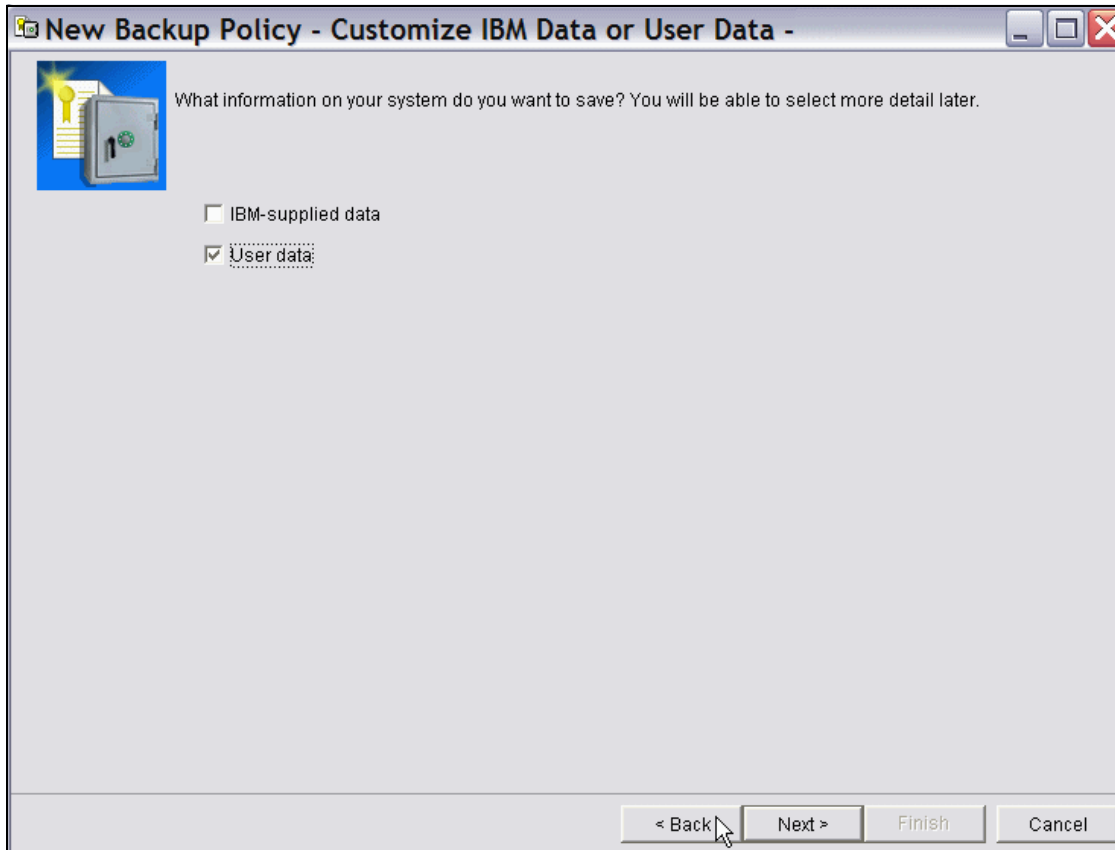

Figure 5-19 BRMS backup policy, customize data

7. In the Customize User Data window shown in Figure 5-20 on page 208, check **Select Lotus servers for online save**, and click **Next**.

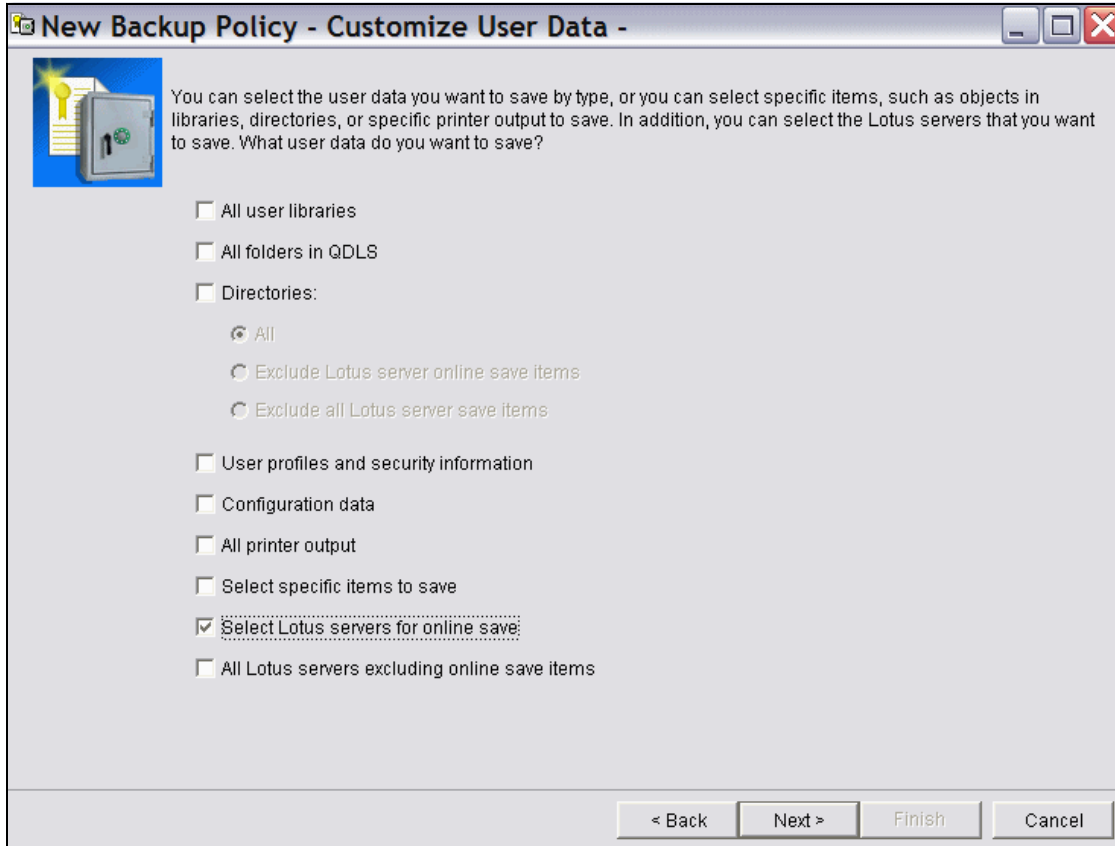

Figure 5-20 BRMS backup policy, customize user data

8. In the Select Lotus Servers for Online Save window displayed in Figure 5-21 on page 209, two Domino servers, DOMINO01 and DOMINO02, are present. In this scenario, only DOMINO02 is backed up. Therefore, the concept of order does not apply.

Select the Domino server (in this scenario, **DOMINO02**) and click **Next**.

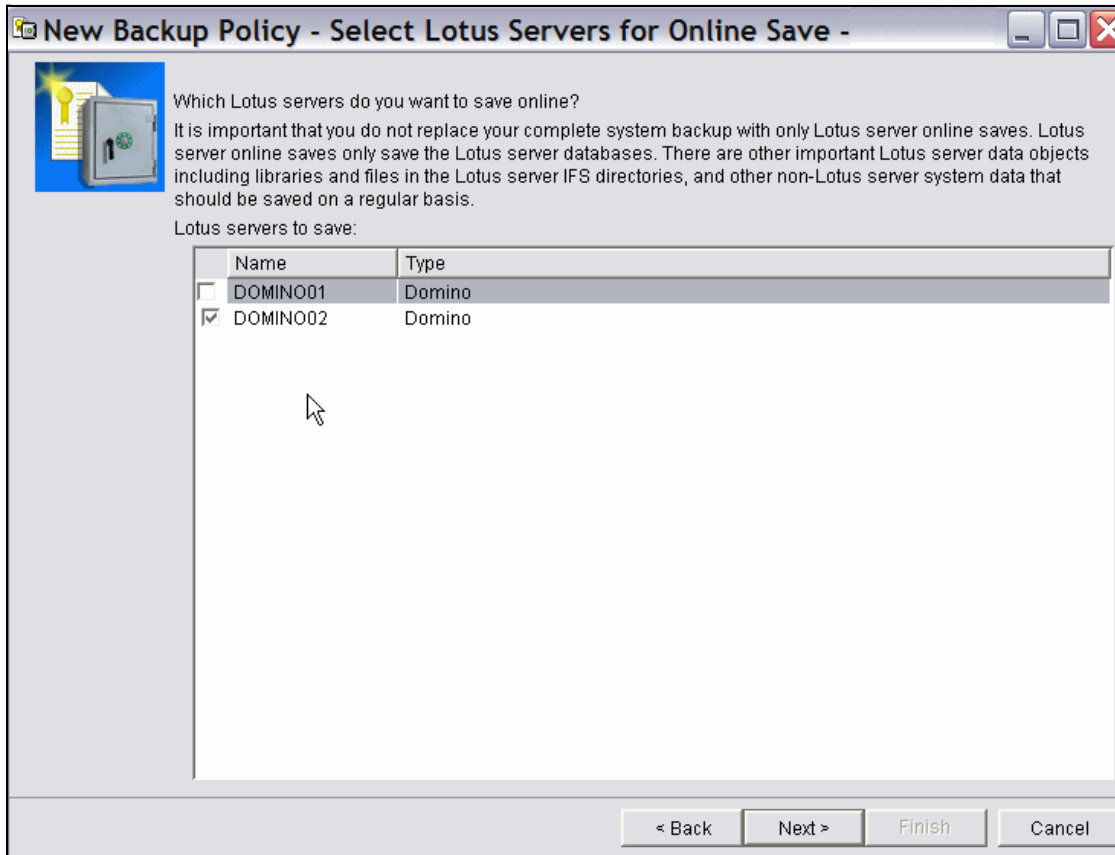

Figure 5-21 BRMS backup policy, select Lotus servers for online backup

9. The Domino Save Order window shown in Figure 5-22 on page 210 shows the order in which backup is done. In this scenario, since only one Domino server is selected, the concept of order does not hold good. Click **Next**.

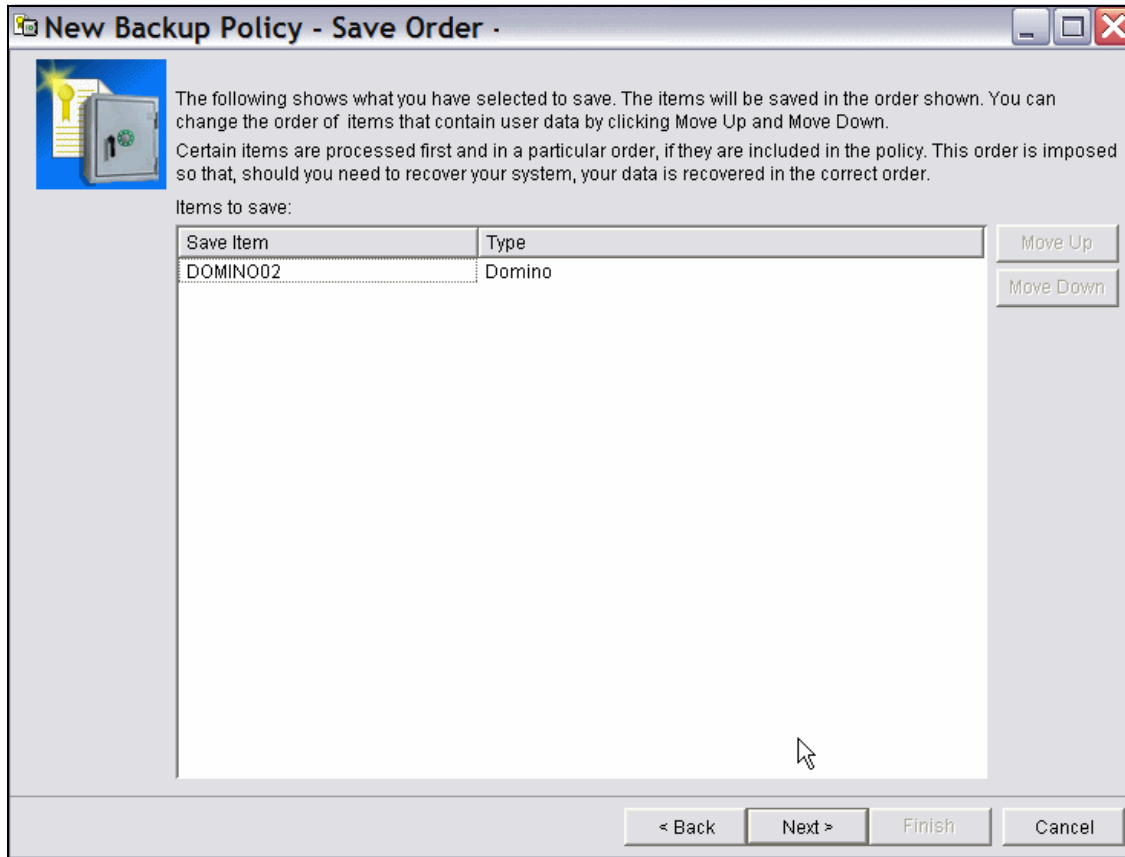

Figure 5-22 BRMS backup policy, save order

- The Save Activity window is shown in Figure 5-23 on page 211. Since DOMINO02 is a minor server, everything is backed up to make recovery easier. To do this, select **Full save**. Against Changes only, select **Changes since last save (incremental)**. Select **Allow overrides...** and then click **Next**.

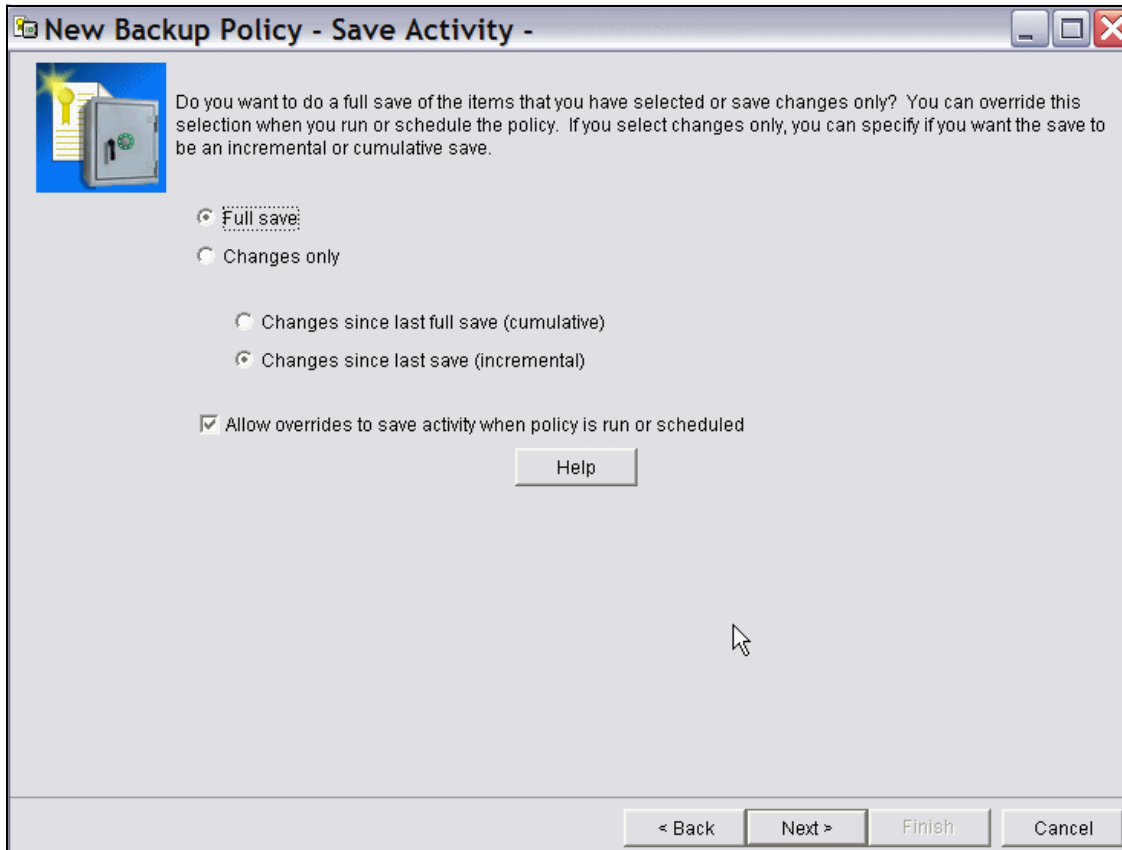

Figure 5-23 BRMS backup policy, save activity

11. In the Where to Save window shown in Figure 5-24 on page 212, select **Save to media**, and click **Next**.

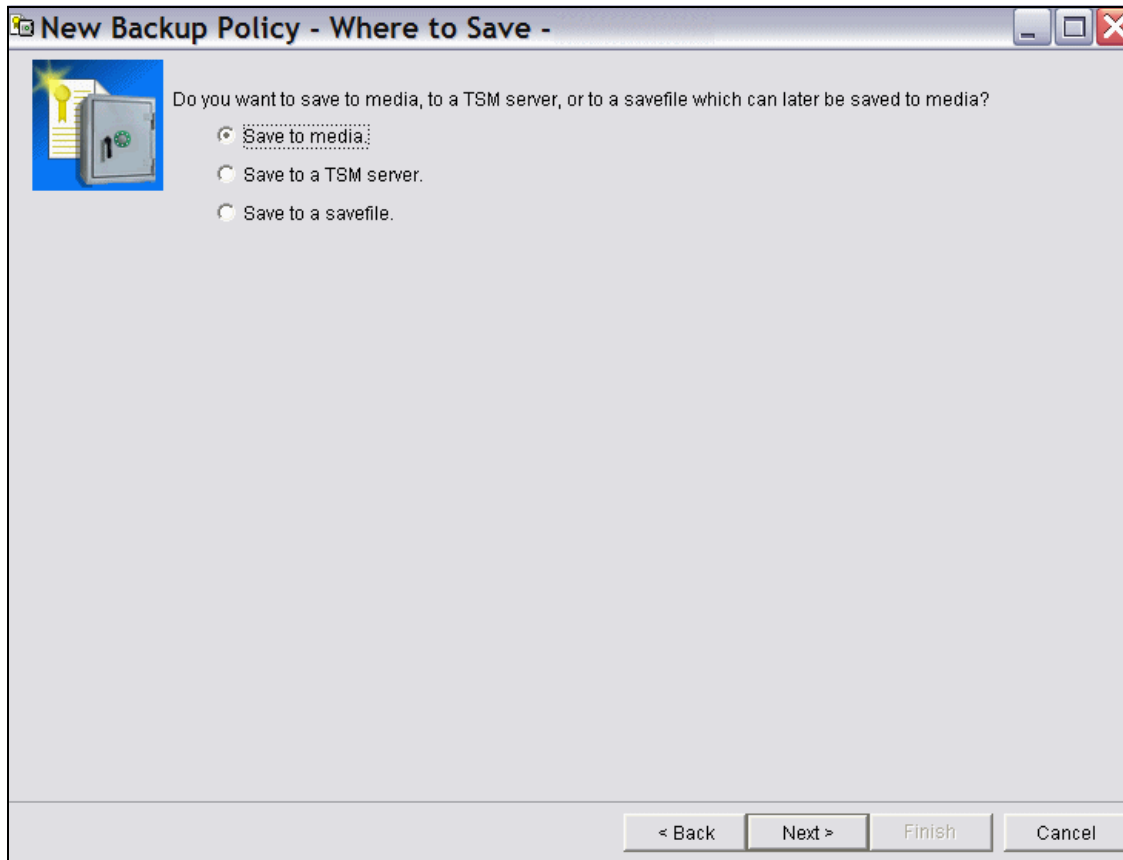

Figure 5-24 BRMS backup policy, where to save

12. In the Select Devices window shown in Figure 5-25 on page 213, against Media pool, select the pool used in this scenario (**Vrt256k**), and click **Next**.

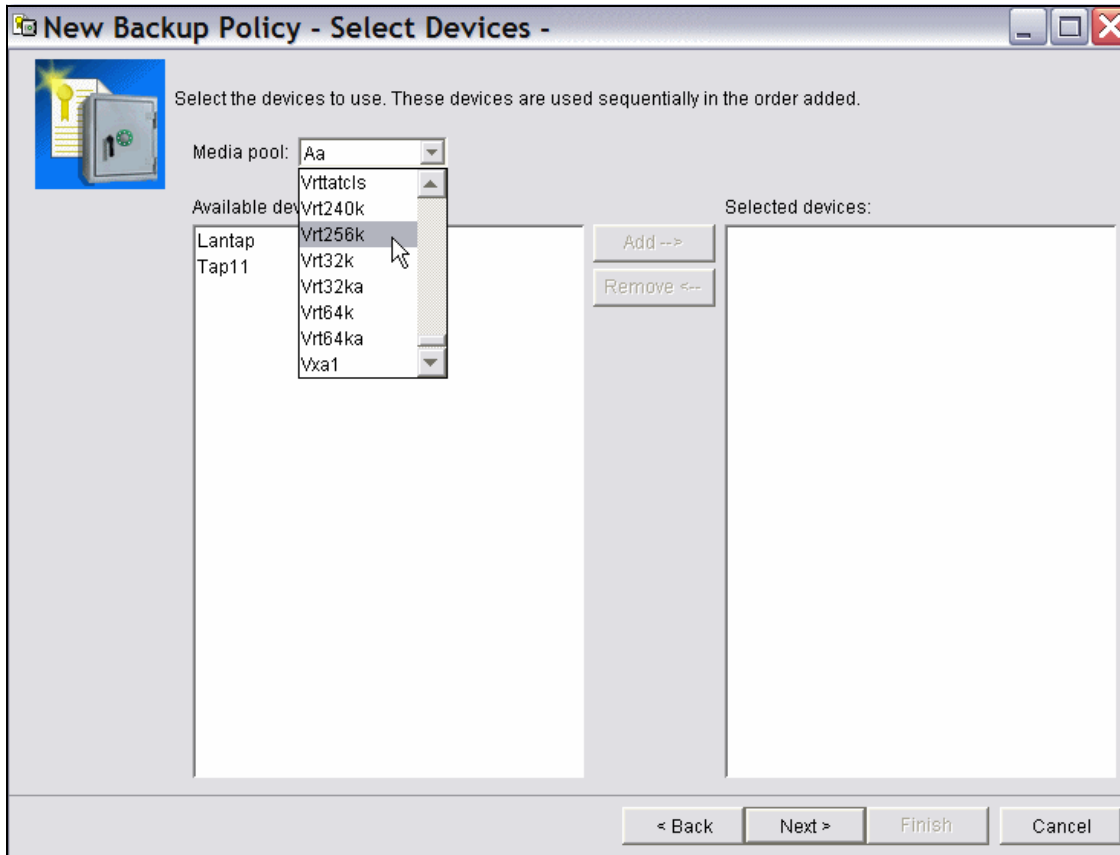

Figure 5-25 BRMS backup policy, select devices

13. Selecting media pool Vrt256k automatically displays the tape drives that can handle pool Vrt256k, as shown in Figure 5-26 on page 214. Select the virtual tape drive (**Tapvrt02**) and click **Add**.

**Note:** All virtual tape drives can handle all virtual densities.

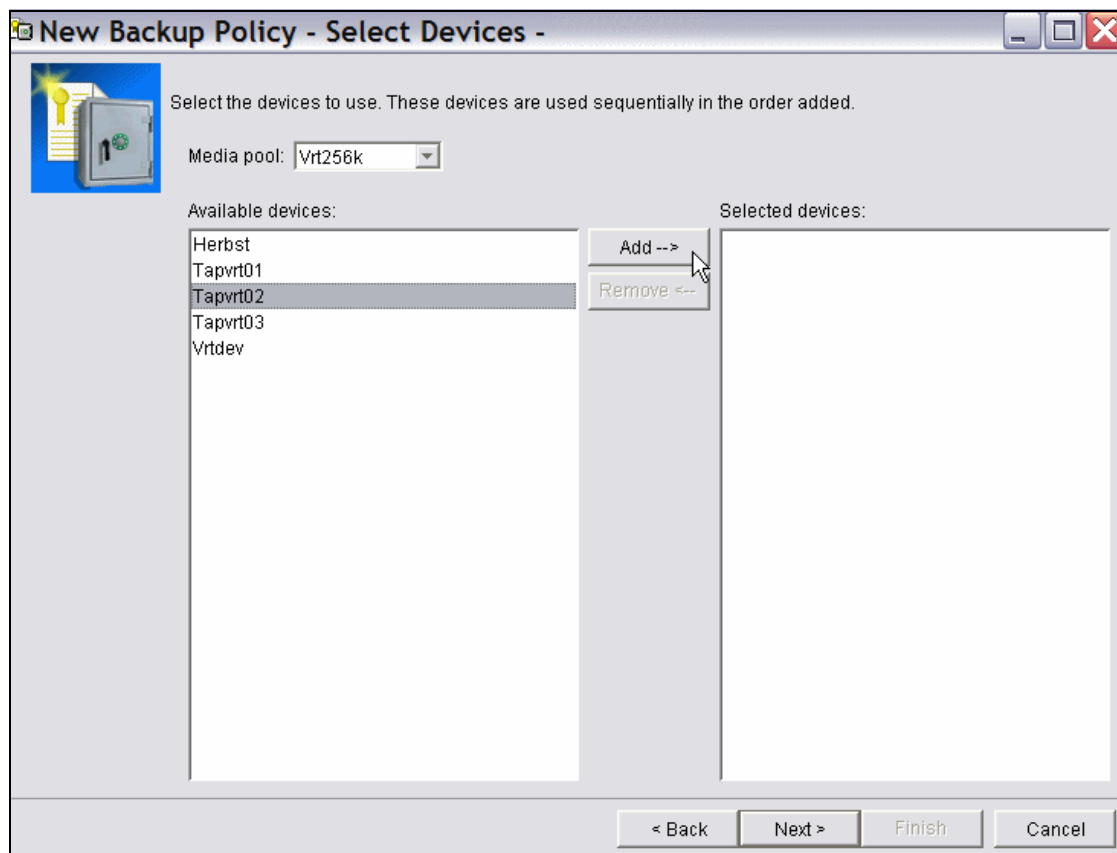

Figure 5-26 BRMS backup policy, select devices for Vrt256k media pool

This adds tape device TAPVRT02, as shown in Figure 5-27 on page 215. Click **Next**.

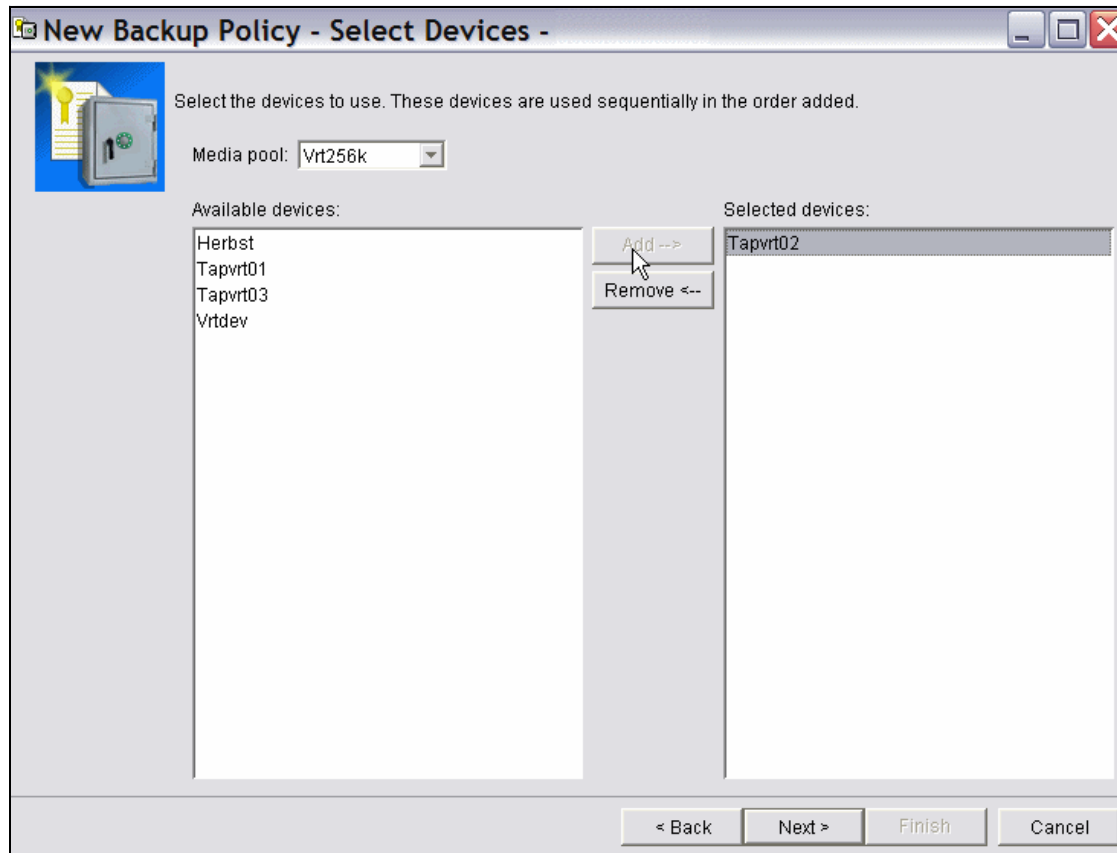

Figure 5-27 BRMS backup policy, select devices - selected

14. Virtual media should always be secured to physical media. In the Duplicate Media window shown in Figure 5-28 on page 216, select **Yes, mark the media for duplication**, and click **Next**.

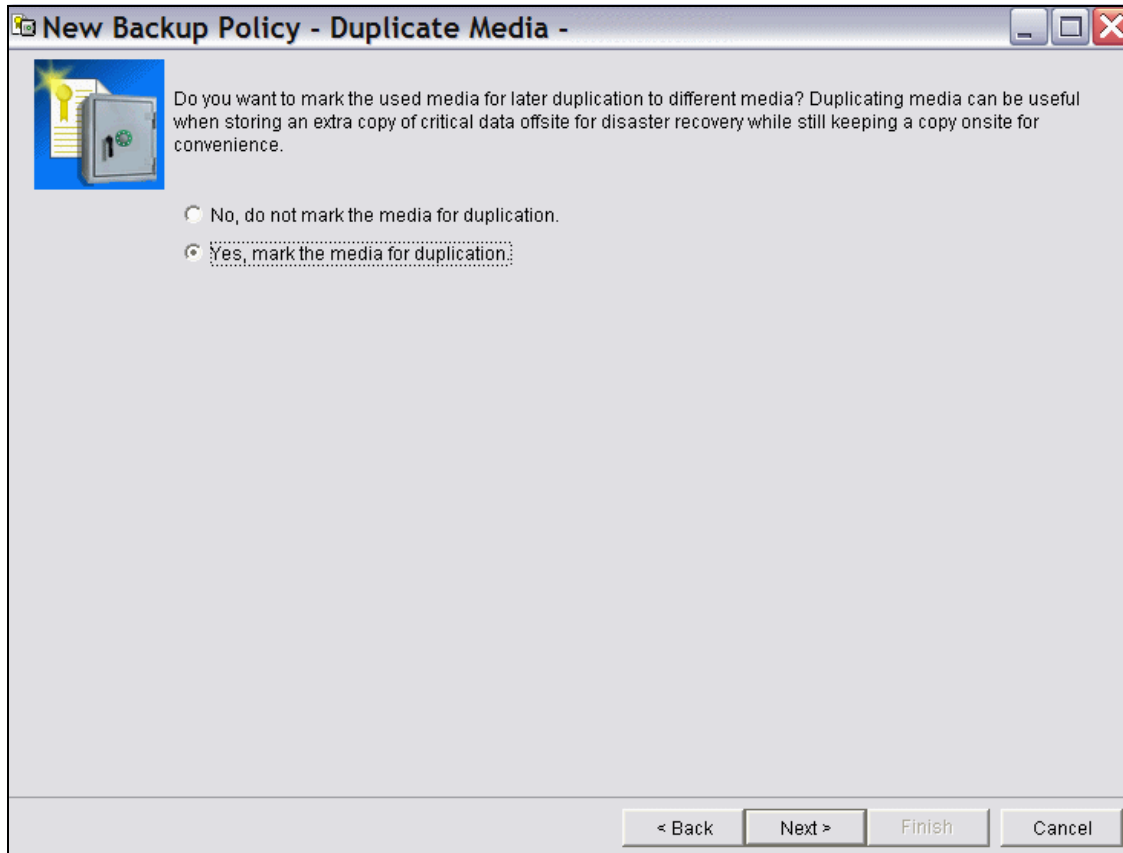

Figure 5-28 BRMS backup policy, duplicate media

15. Since BRMS maintenance will not be run every time a backup of this Domino server is done, in the Run Maintenance window shown in Figure 5-29 on page 217, select **No, do not run maintenance after save**, and click **Next**.

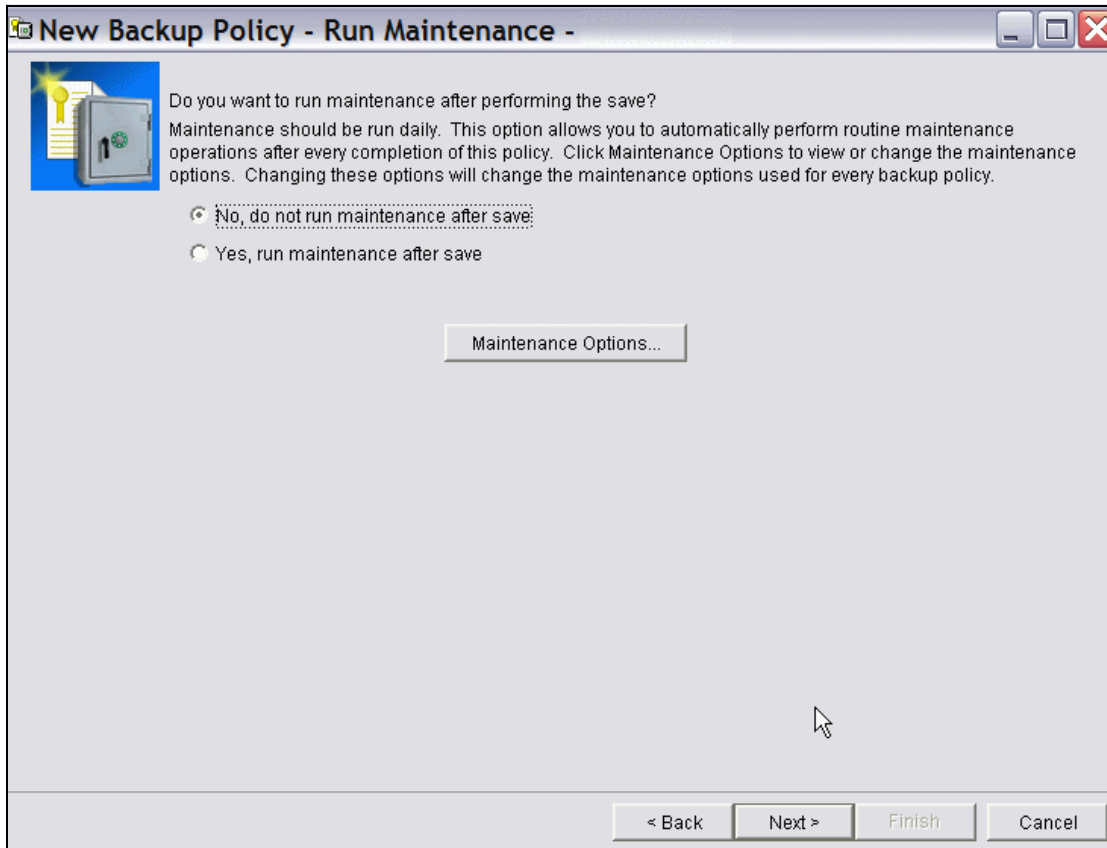

Figure 5-29 BRMS backup policy, run maintenance

16. To add virtual volumes to BRMS, in the Add Media window displayed in Figure 5-30 on page 218, click **Add Media**.

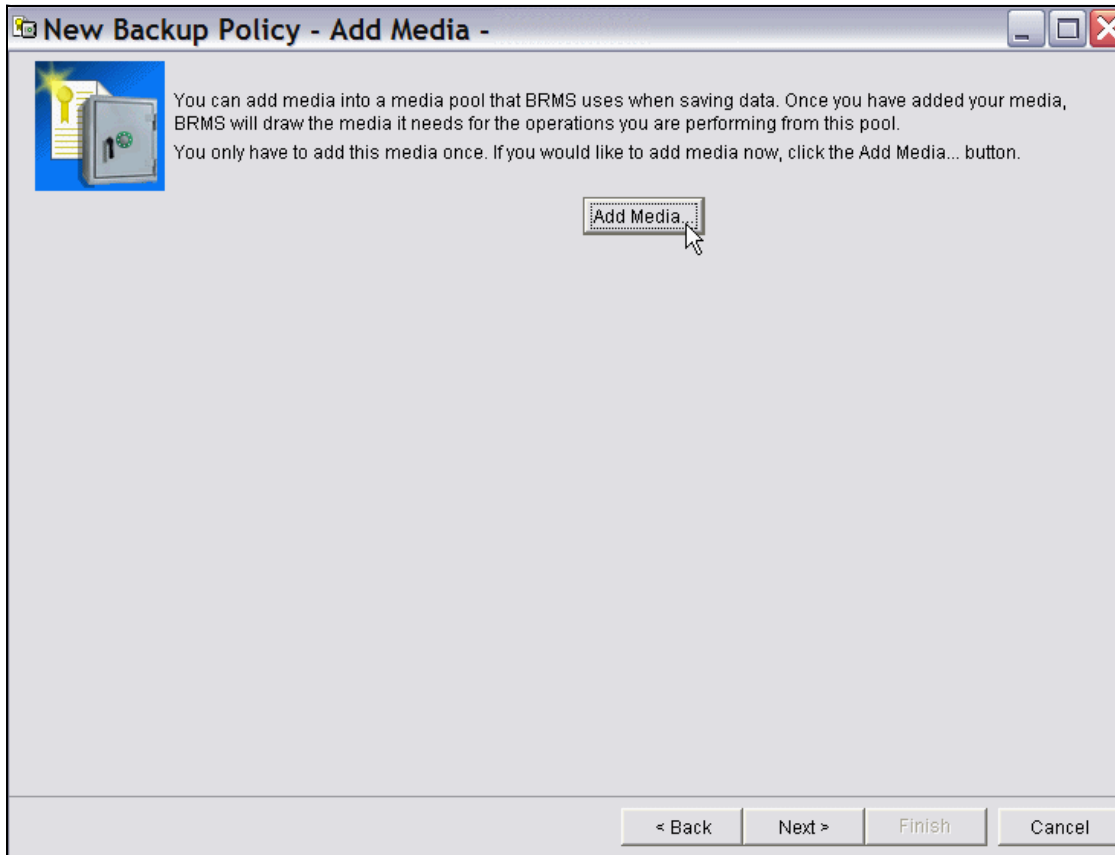

Figure 5-30 BRMS backup policy, add media

17. In the welcome page that appears, click **Next**.
18. To specify where the virtual volumes are, scroll down against Image catalog in the Select Image Catalog window shown in Figure 5-31 on page 219, and select the corresponding value (**Dominovrt**). Click **Next**.

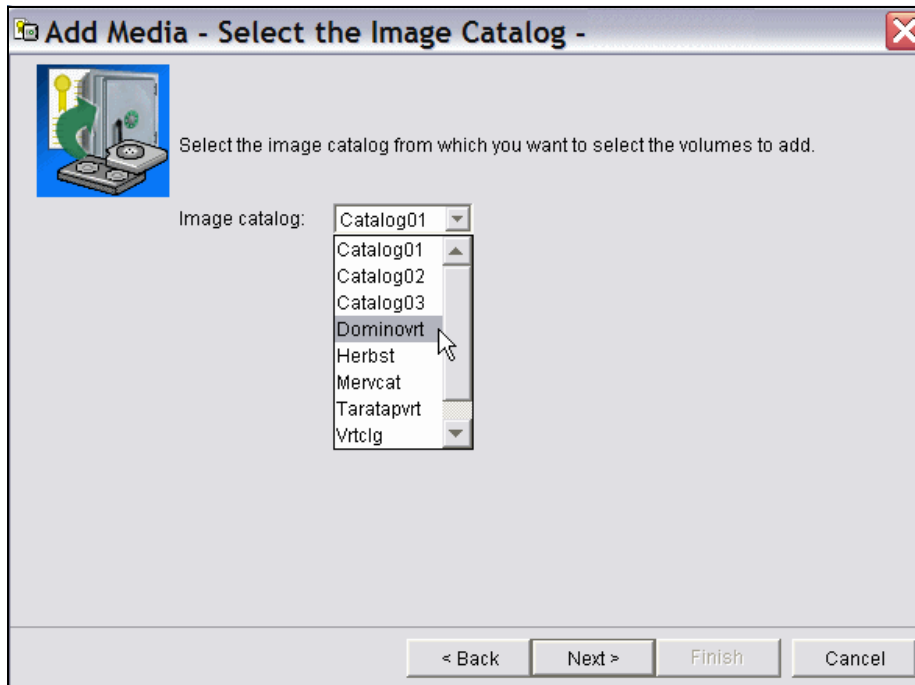

Figure 5-31 BRMS backup policy, select image catalog to pick volumes from

19. In this scenario, only three volumes are added. To use all of them, select them one after the other or check **Select all**, and click **Next**, as shown in Figure 5-32 on page 220.

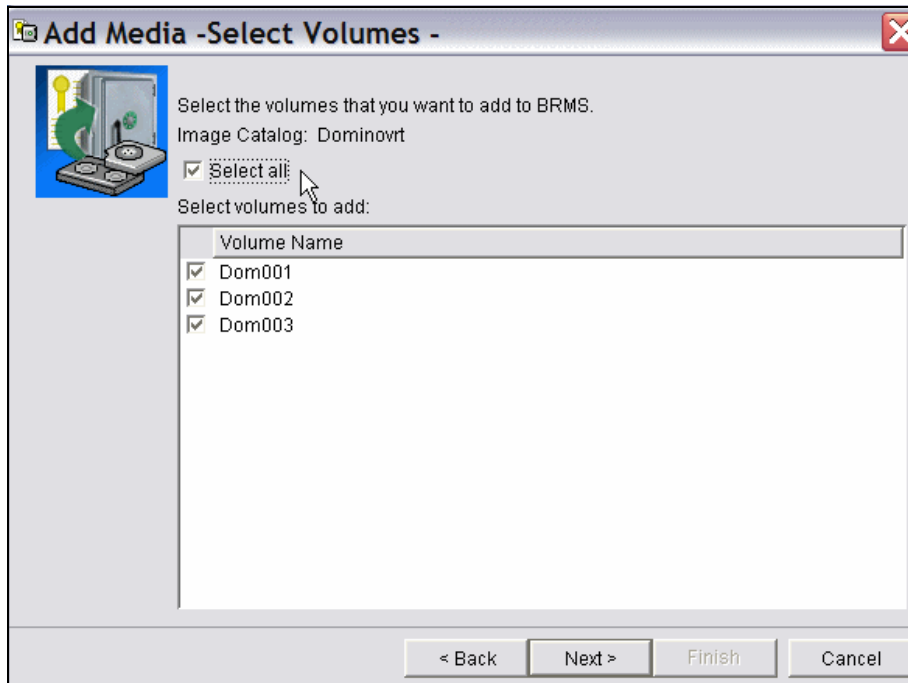

Figure 5-32 BRMS backup policy, select volumes

20. The normal start in BRMS is to create locations first. With the Navigator, you do not have to, since it can be done on the fly. Click **New Location** in the Select Media Storage Location window shown in Figure 5-33 on page 221, select a location, and then click **Next**.



Figure 5-33 BRMS backup policy, create media storage location

21. In the New Storage Location window shown in Figure 5-34 on page 222, input the following parameters, and click **OK**:

- Input a value for Location name (in this scenario, it was domi novrt).
- Input a value for Description.

**Note:** Do not allow volumes to expire.

**New Storage Location -**

Location name:

Description:

Address (up to 5 lines):

Contact name:

Telephone number:

E-mail address:

Retrieval time:  hours

Allow volumes to expire at this location

Advanced... OK Cancel Help ?

Figure 5-34 BRMS backup policy, new storage location

22. Location **Dominovrt** is created. However, another location is needed to house the volumes so that they can expire after being duplicated. Click **New Location** in the Select Media Storage Location window shown in Figure 5-35 on page 223, and then click **Next**.



Figure 5-35 BRMS backup policy, create next location

23. In the New Storage Location window shown in Figure 5-36 on page 224, input the location name as `copy_ok`. Input values as was done for location `dominovrt` (step 21 on page 221). The only exception is that in this window, you must select **Allow volumes to expire at this location**. Click **OK**.

**New Storage Location -**

Location name:

Description:

Address (up to 5 lines):

Contact name:

Telephone number:

E-mail address:

Retrieval time:  hours

Allow volumes to expire at this location

Advanced... OK Cancel Help ?

Figure 5-36 BRMS backup policy, next location

24. The locations are created. To select the location into which the added volumes will be placed, in the Select Media Storage Location window shown in Figure 5-37 on page 225, scroll down against Location and select the relevant one (**Dominovrt**) and click **Next**.

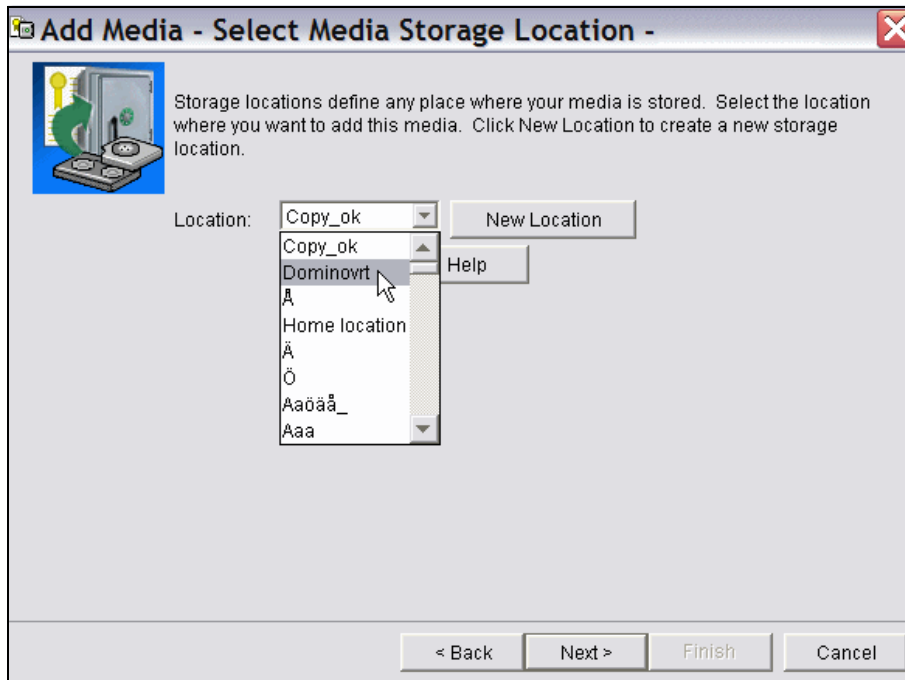

Figure 5-37 BRMS backup policy, select media storage location

25. BRMS can initialize the volumes, if required. In this scenario, since this is already done, click **Next** in the Initialize Volumes window shown in Figure 5-38 on page 226.

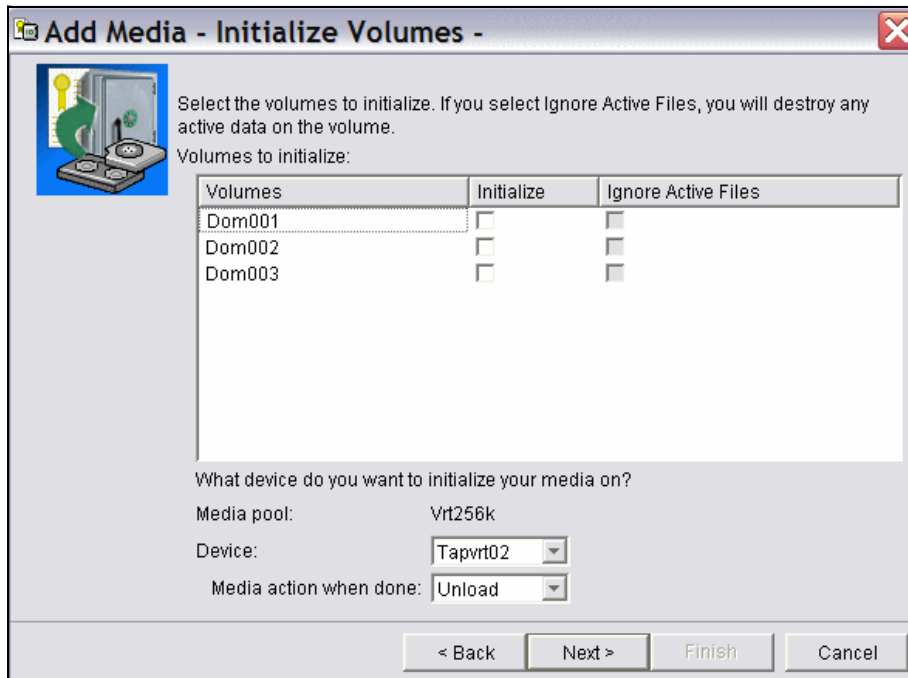

Figure 5-38 BRMS backup policy, initialize volumes

26. In the Add Media Summary window shown in Figure 5-39 on page 227, click **Finish**.

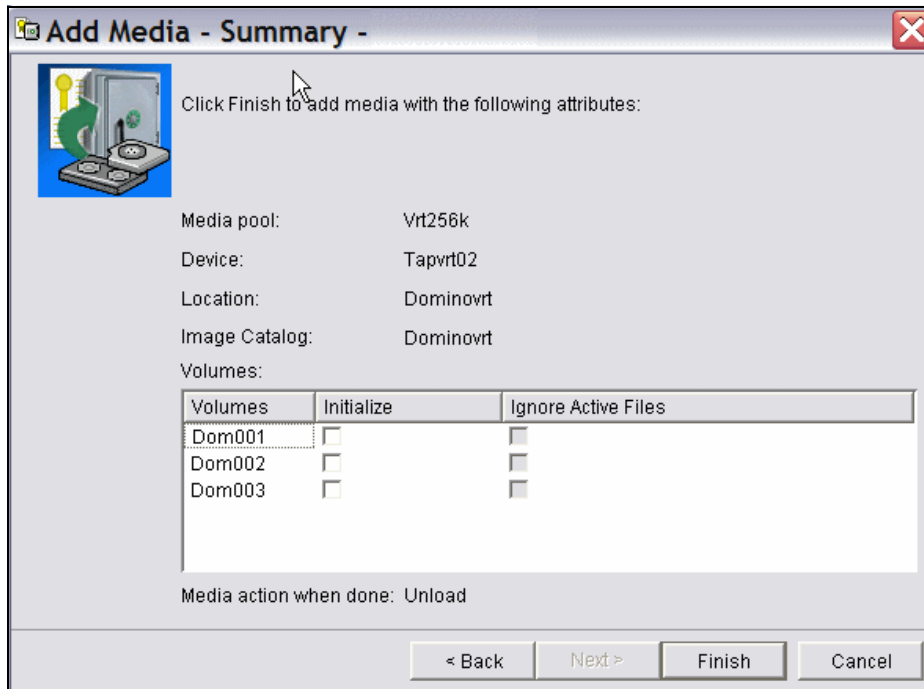

Figure 5-39 BRMS backup policy, add media summary

27. In the Add Media window shown in Figure 5-40 on page 228, click **Next**.

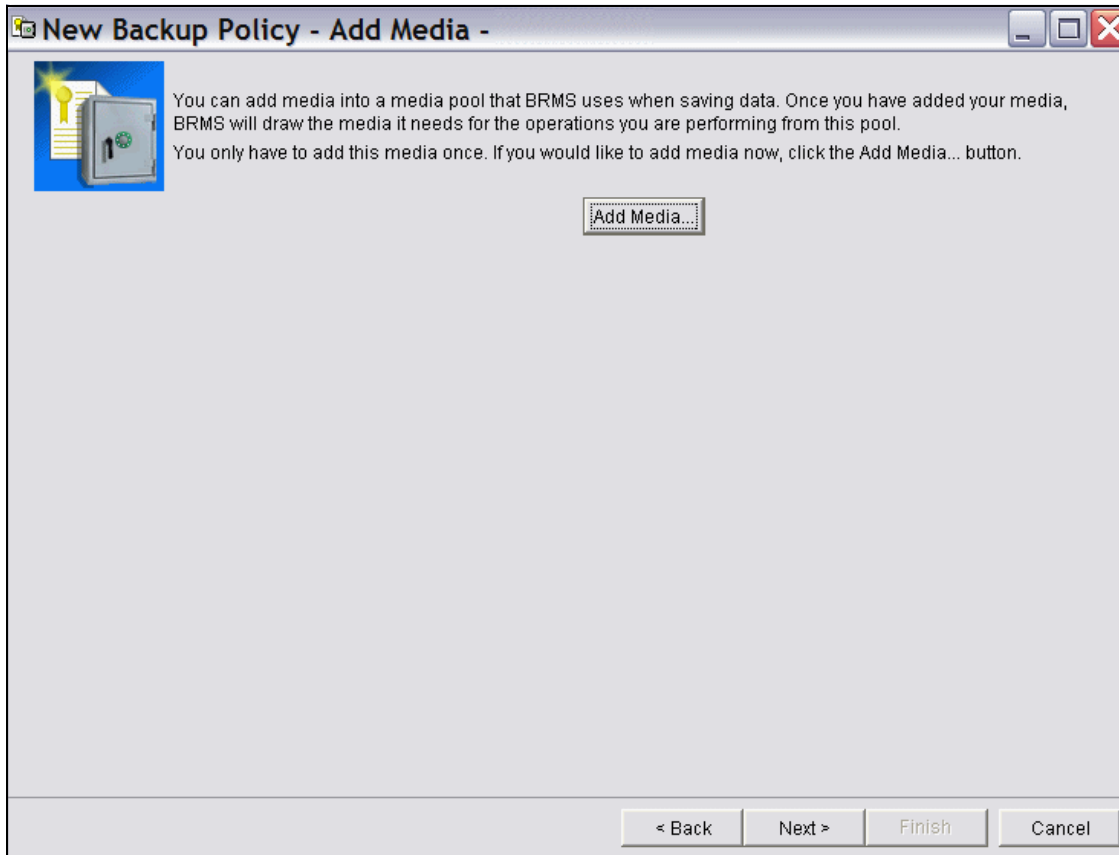

Figure 5-40 BRMS backup policy, add media done

28. In the New Backup Policy Summary window shown in Figure 5-41 on page 229, click **Finish**.

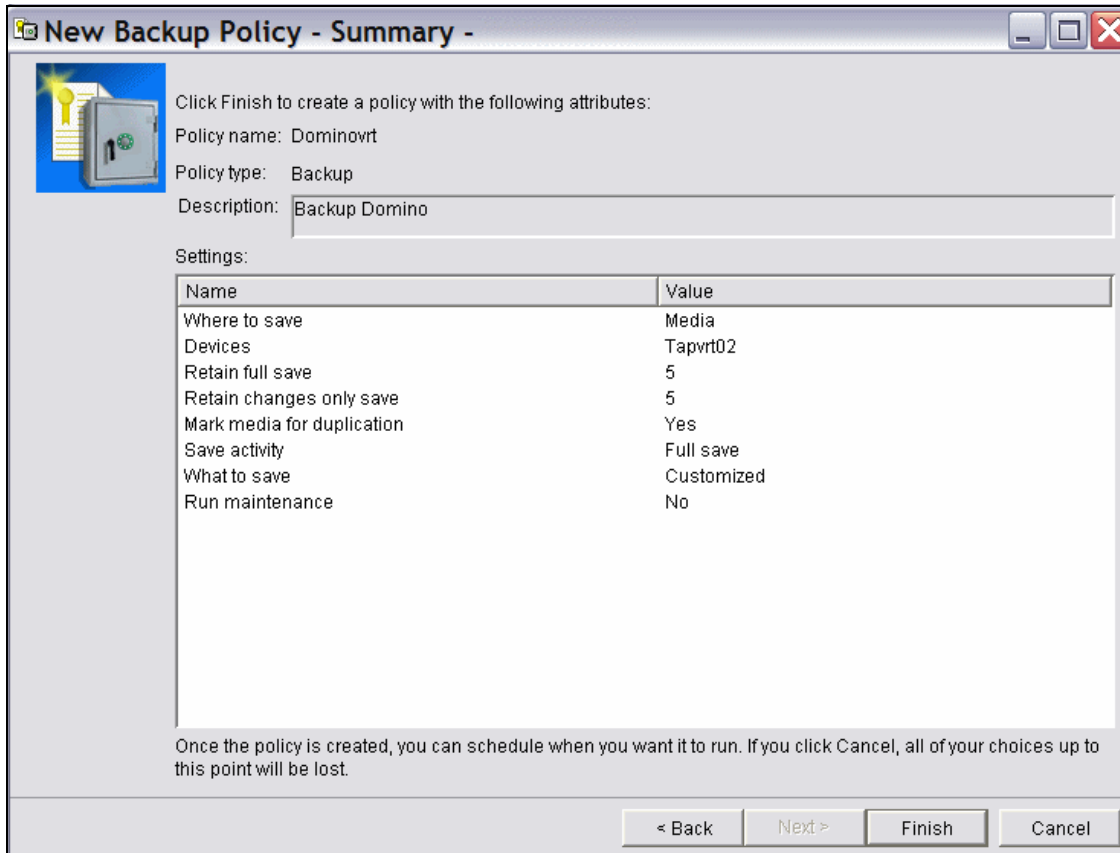

Figure 5-41 BRMS backup policy, summary

29. In the window shown in Figure 5-42 on page 230, click **Done**.

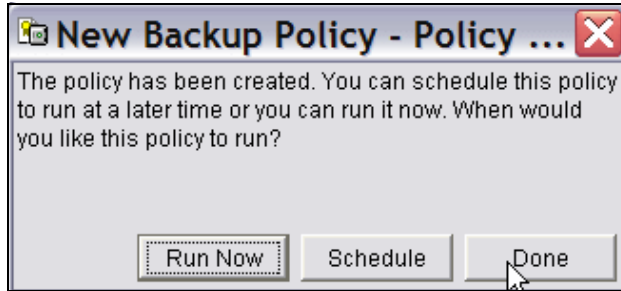

Figure 5-42 BRMS backup policy, run now or later

30. The base portion of the backup policy is created. Press F5. This concludes the process of creating a backup policy.

### 5.3 Creating a move policy

After the base backup policy is created, create a move policy to attach to it. Otherwise, you have to manually move the volumes.

### 5.3.1 Creating a move policy for virtual volumes

To create move policy for virtual volumes, perform the following tasks:

1. Expand **Backup, Recovery and Media Services**, right-click **Move Policies**, and select **New Policy**, as shown in Figure 5-43.

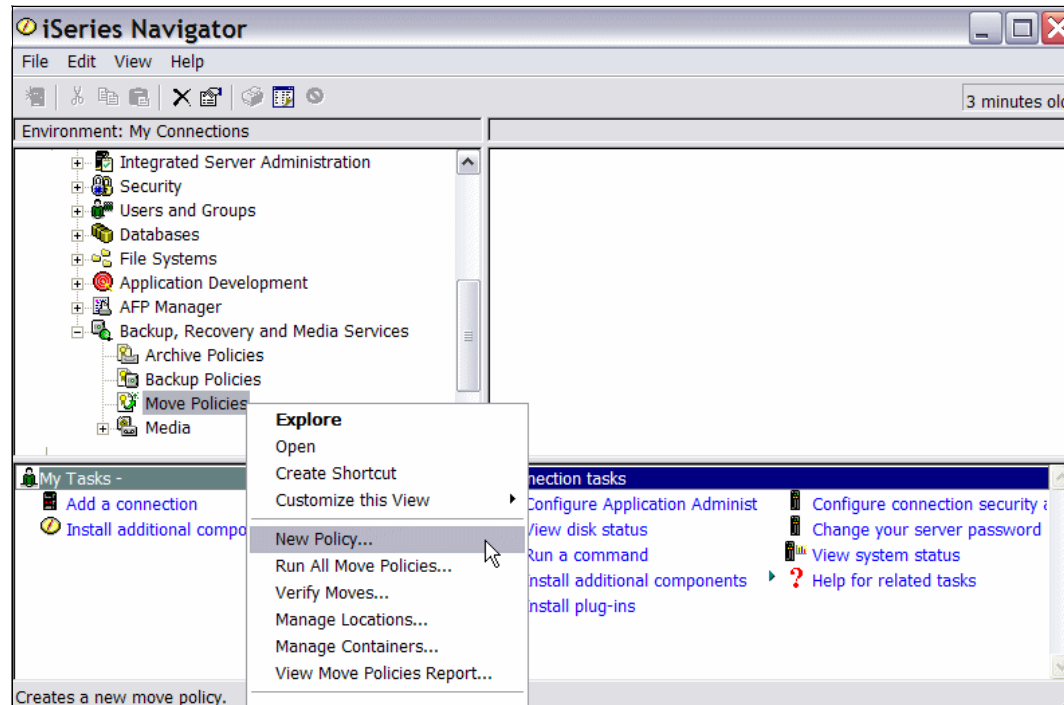

Figure 5-43 Domino with BRMS, move policy, new policy

2. After the Welcome window, the Move Policy Name window shown in Figure 5-44 on page 232 is displayed; input the following parameters:
  - Input value for Move policy name (in this scenario, it is domi nodup).
  - Input value in the Description field.Then click **Next**.

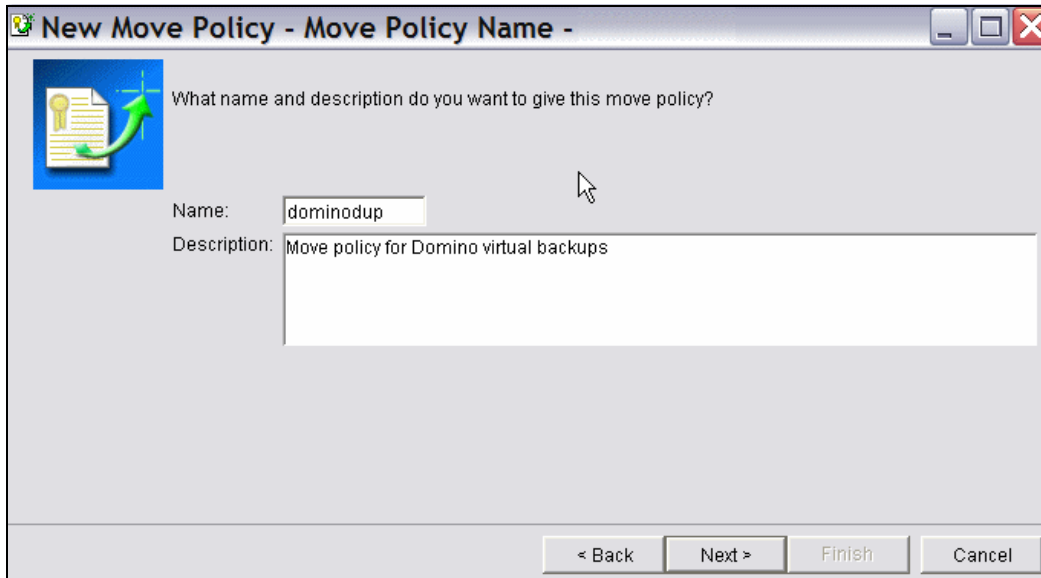

Figure 5-44 BRMS virtual move policy, name

3. In the Storage Locations window shown in Figure 5-45 on page 233, select the location into which the volume will go into after being duplicated. In this scenario, it is **Copy\_ok**. Click **Add Before** or **Add After**, and then click **Next**.

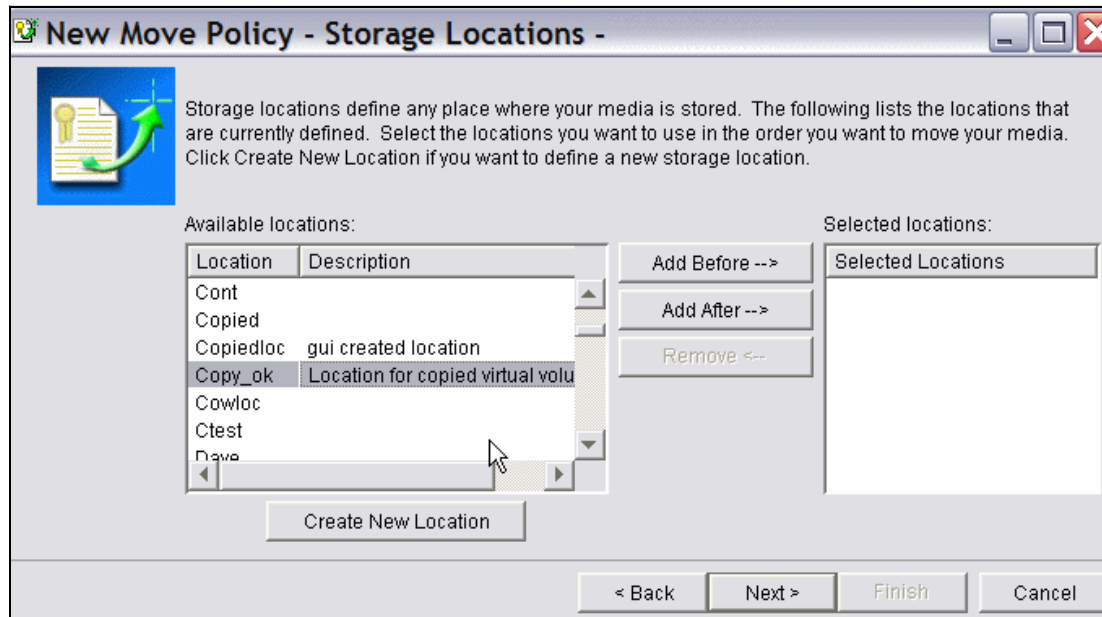

Figure 5-45 BRMS virtual move policy, add in location order

4. Since there is only one step in the move policy in this scenario, there is no need for any other action. Click **Next** in the window, as shown in Figure 5-46 on page 234.

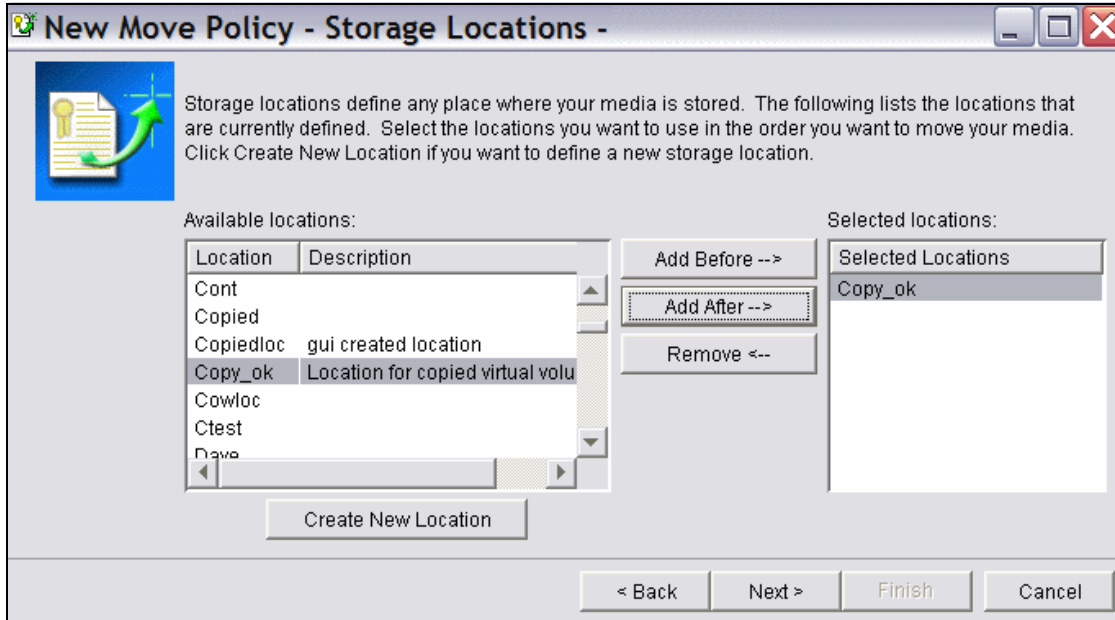

Figure 5-46 BRMS virtual move policy, location order defined

The number of days the volumes will spend at each location should be specified. After the backups are taken, do not move them until they are duplicated.

In this scenario, we let them stay in location Dominovrt. When duplicated, they move to location Copy\_ok, where they await their expiration date.

On that date, the BRMS maintenance job sets the expiration flag and the last portion of movement takes place, that is, bringing them back as scratches into location Dominovrt for reuse.

5. In the New Move Policy - Duration window shown in Figure 5-47 on page 235, the Duration field should display the text `Until media expiration date`. Click **Next**.

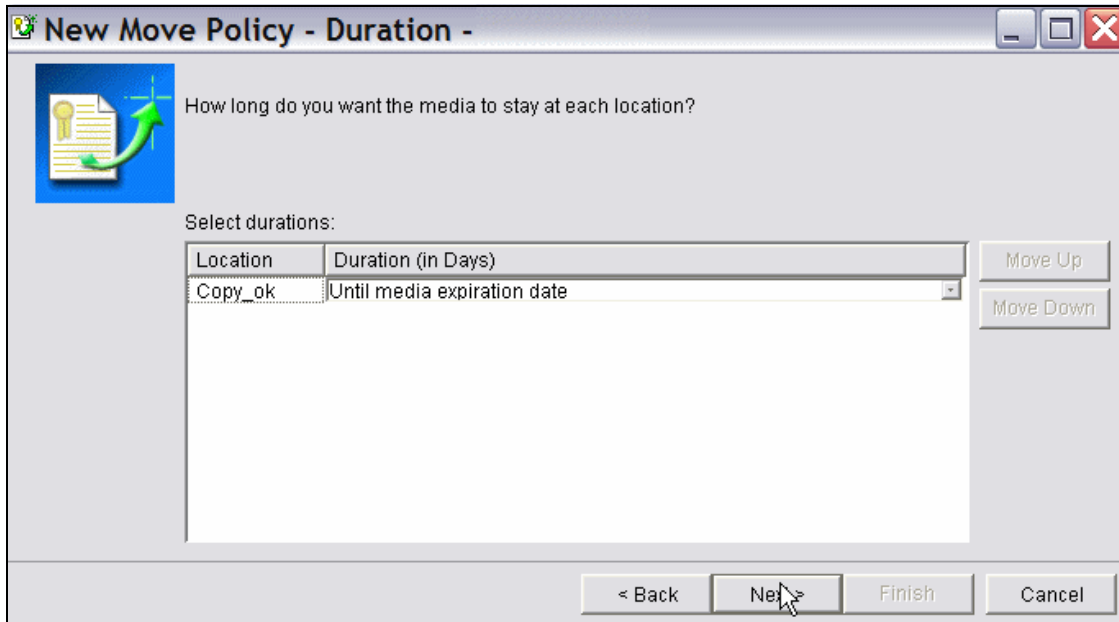

Figure 5-47 BRMS virtual move policy, duration

6. If you want to verify movement, you can do so in the New Move Policy - Verify Moves window shown in Figure 5-48 on page 236.

However, since this action is not required in this scenario, **No** was selected. Click **Next**.

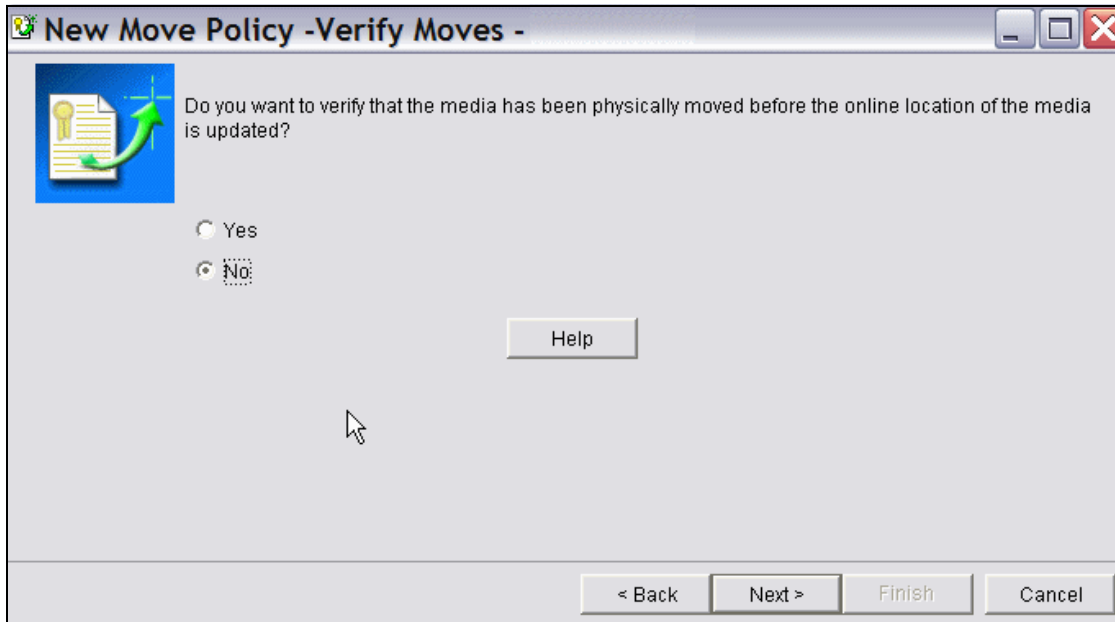

Figure 5-48 BRMS virtual move policy, verify moves

7. Regardless of whether you made a “full” backup or a “changes only” backup, the volumes should reflect the same.

Select both the **Full** and **Changes only** options against the corresponding volume, and click **Next**, in the New Move Policy - Select Policies window shown in Figure 5-49 on page 237.

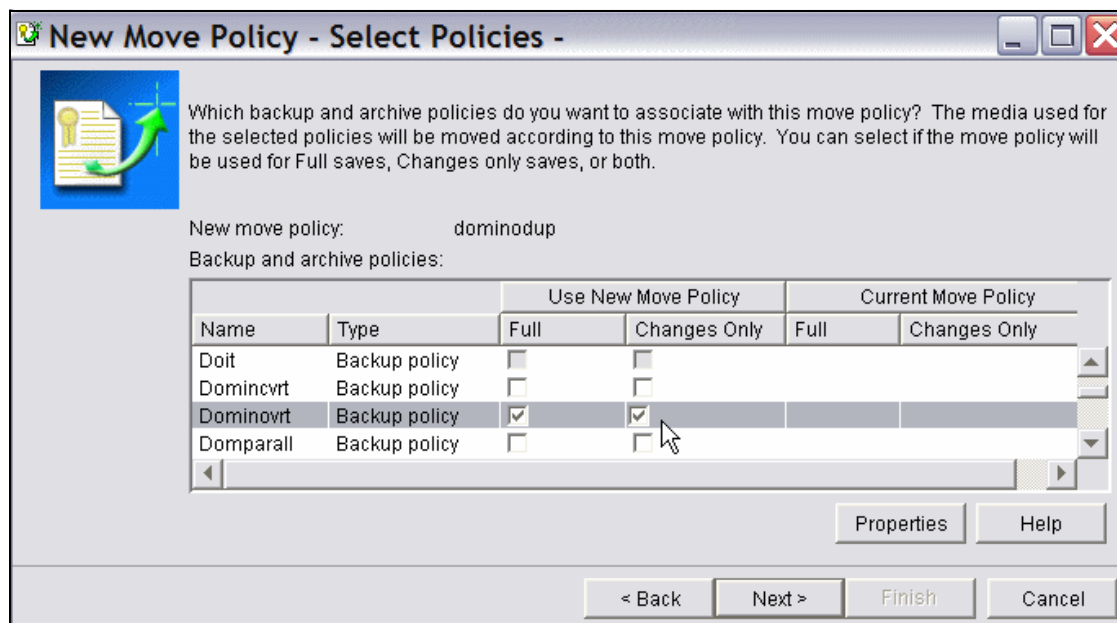

Figure 5-49 BRMS virtual move policy, summary

8. In the Summary window shown in Figure 5-50 on page 238, click **Finish**.

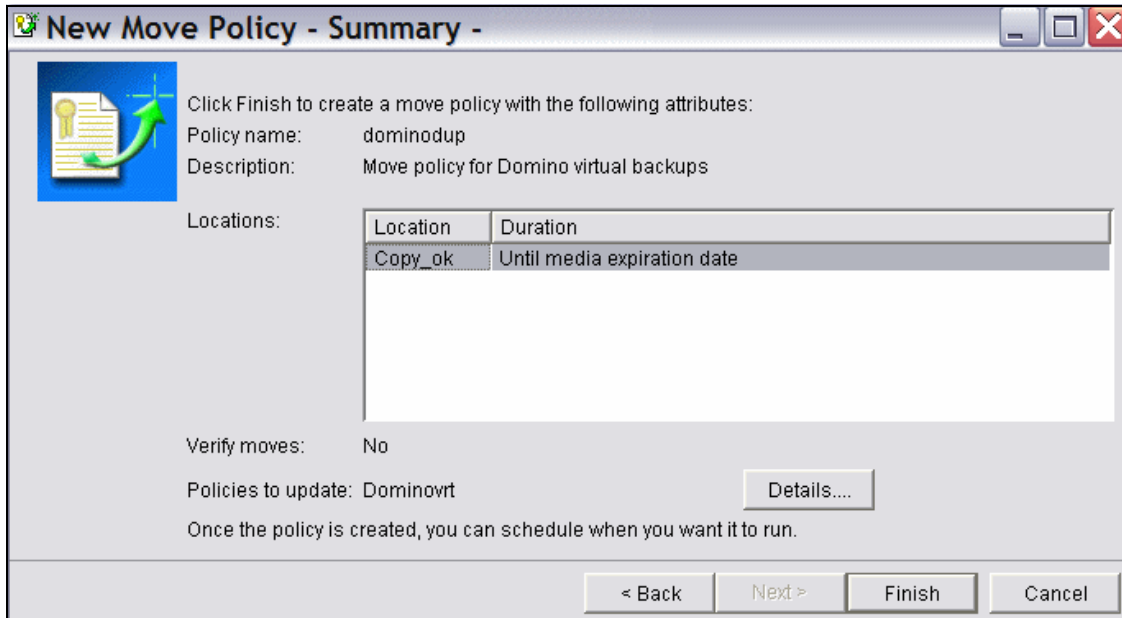

Figure 5-50 BRMS virtual move policy, summary

9. Click **Done** in the Move Policy Created window shown in Figure 5-51.

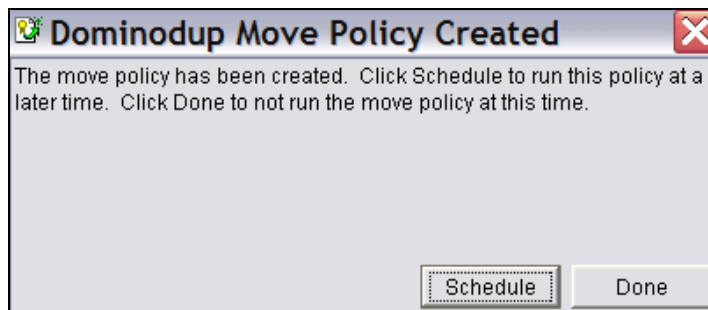

Figure 5-51 BRMS virtual move policy, created

The first move policy is now created. This policy is used for the virtual volumes. Another move policy is required for the physical volumes that result from duplicating. However, adjustments should be made to the new virtual move policy first.

The move policy takes care of volumes that are expired. Therefore, a minor adjustment is required in the policy, as described in the next section.

## 5.3.2 Adjusting the virtual move policy

Perform the following tasks to adjust the newly created virtual move policy:

1. Right-click the new move policy (in this scenario, **Dominodup**), and select **Properties**, as shown in Figure 5-52.

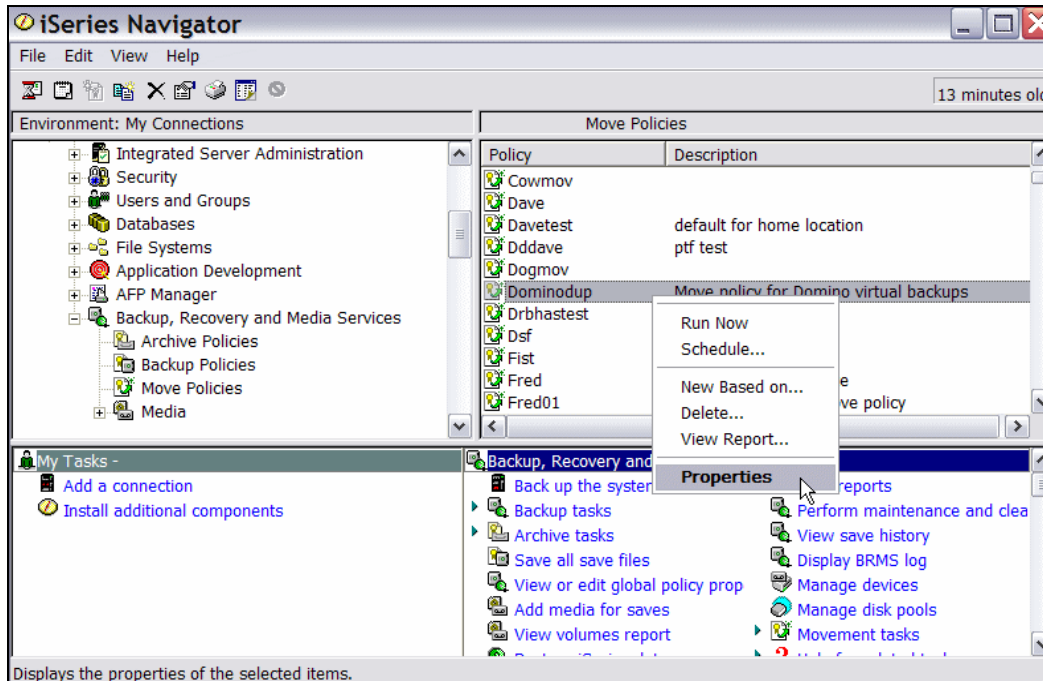

Figure 5-52 BRMS move policy for virtual volumes, change

2. In the window shown in Figure 5-53 on page 240, click the **Locations** tab. The field Location to move when complete probably states Home location. This means that the volumes go back to where they came from. In this scenario, we want them to go back to the location Dominovrt in all cases.

Use **Browse...** to select the location you want as the end station when the virtual volumes' retention period is up (in this scenario, it is **Dominovrt**). Click **OK**, as shown in Figure 5-53 on page 240.

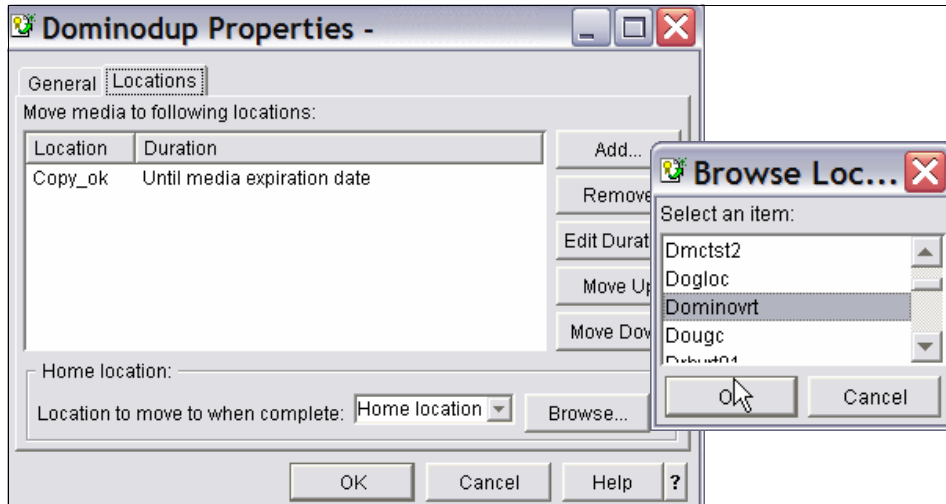

Figure 5-53 BRMS move policy for virtual volumes, Properties - Locations tab

Figure 5-54 shows that the move policy has changed accordingly. Click **OK**.

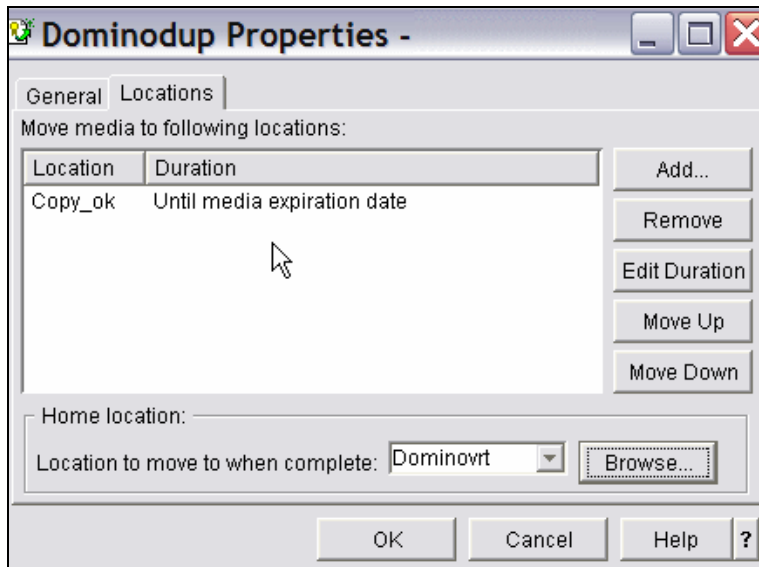

Figure 5-54 BRMS move policy for virtual volumes, changed

This concludes the actions you need to perform regarding the move policy for virtual volumes.

### 5.3.3 Creating a move policy for physical volumes

A move policy is also required for physical volumes. This policy defines where the physical volumes will go after they are duplicated.

You can create a move policy by bringing up the new move policy for virtual volumes and proceeding as described earlier, with the one exception that you point to a meaningful location.

Alternatively, you can follow our example. In this scenario, we used the move policy OFFSITE automatically created by BRMS. It has only two steps:

1. Bring the volumes to location VAULT, as shown in Figure 5-55.
2. Bring them back when the retention period is up.

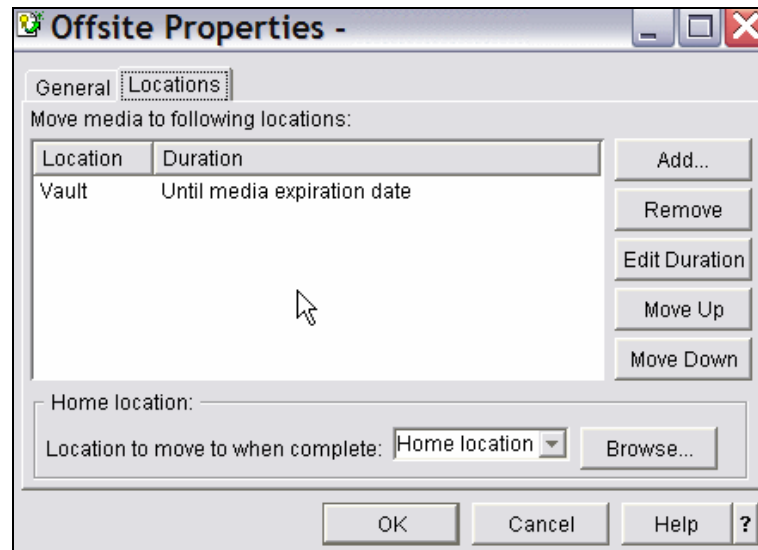

Figure 5-55 BRMS standard move policy OFFSITE

As of now, the following are available:

- ▶ An image catalog.
- ▶ The image catalog contains virtual tape volumes.
- ▶ There are three initialized virtual tape volumes in the image catalog.
- ▶ The image catalog is loaded to a virtual tape drive.
- ▶ One of the tape volumes is mounted.
- ▶ The other two volumes are loaded or are ready to be mounted.

Now, there are two additions:

- ▶ A move policy for virtual volumes.
- ▶ Use the OFFSITE move policy for physical volumes.

The next task is to adjust the backup policy, which also includes marrying it to the move policy.

## 5.4 Adjusting the backup policy

At this point, the backup policy is ready to run. However, it has to be tailored to specific needs. Therefore, the backup policy should be adjusted, as follows:

1. Click **Backup policies**.
2. Select **Backup, Recovery and Media Services**, right-click **Dominovrt** and select **Properties**, as shown in Figure 5-56.

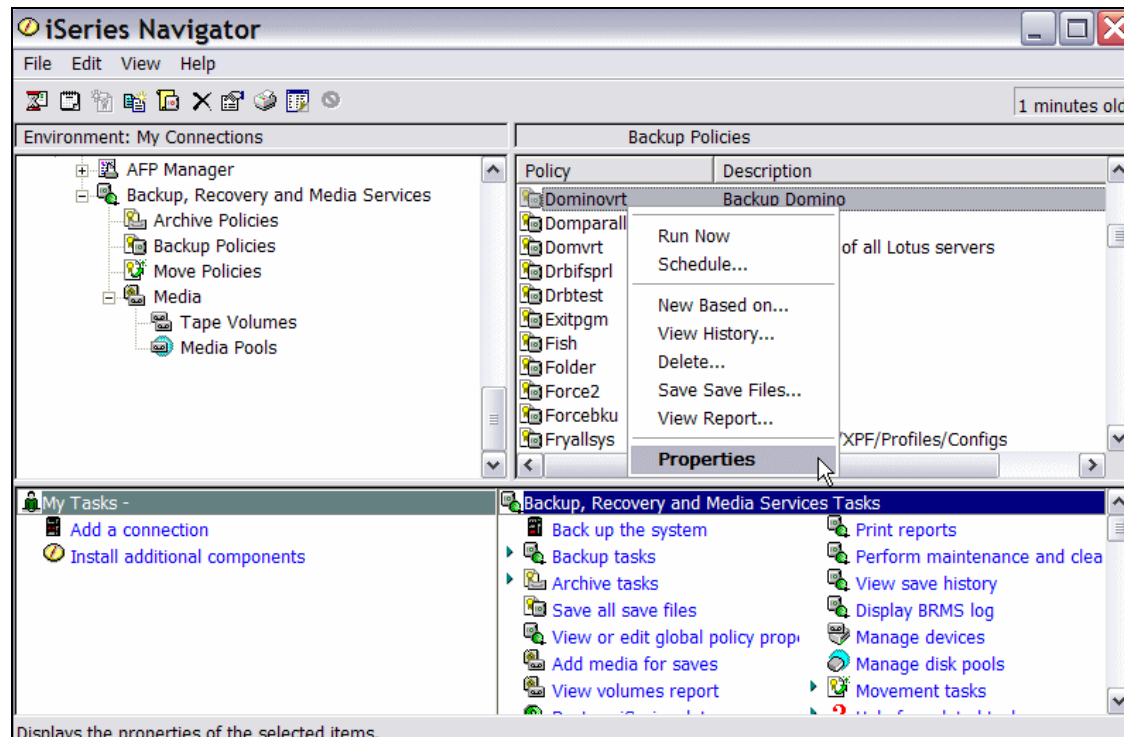

Figure 5-56 BRMS move policy change, select properties

3. You should now verify a few items prior to running the backup. Click **Before** in the Properties window shown in Figure 5-57.

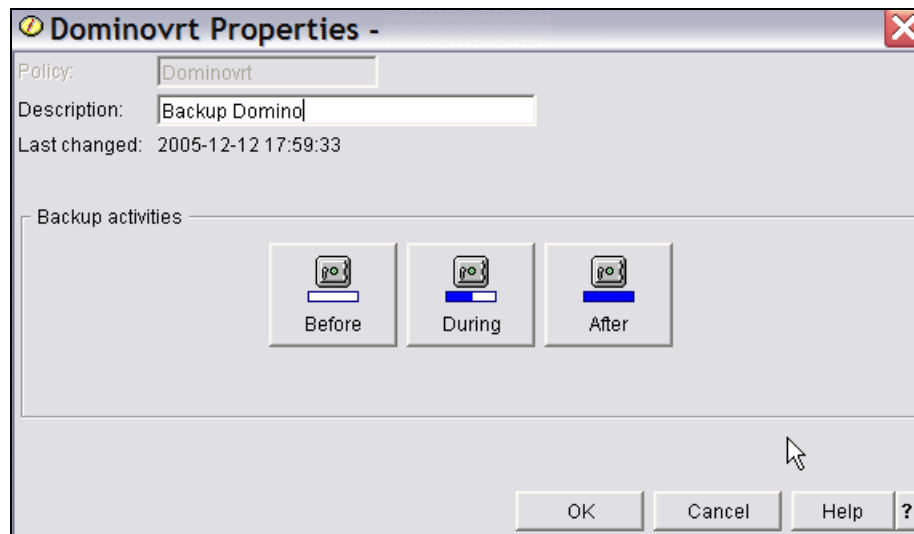

Figure 5-57 BRMS move policy change, Before/During/After Save

4. In the Before Save window shown in Figure 5-58 on page 244, click the **General** tab, and make sure that no servers are taken down. Also, allow all users to remain active. Click **OK**.

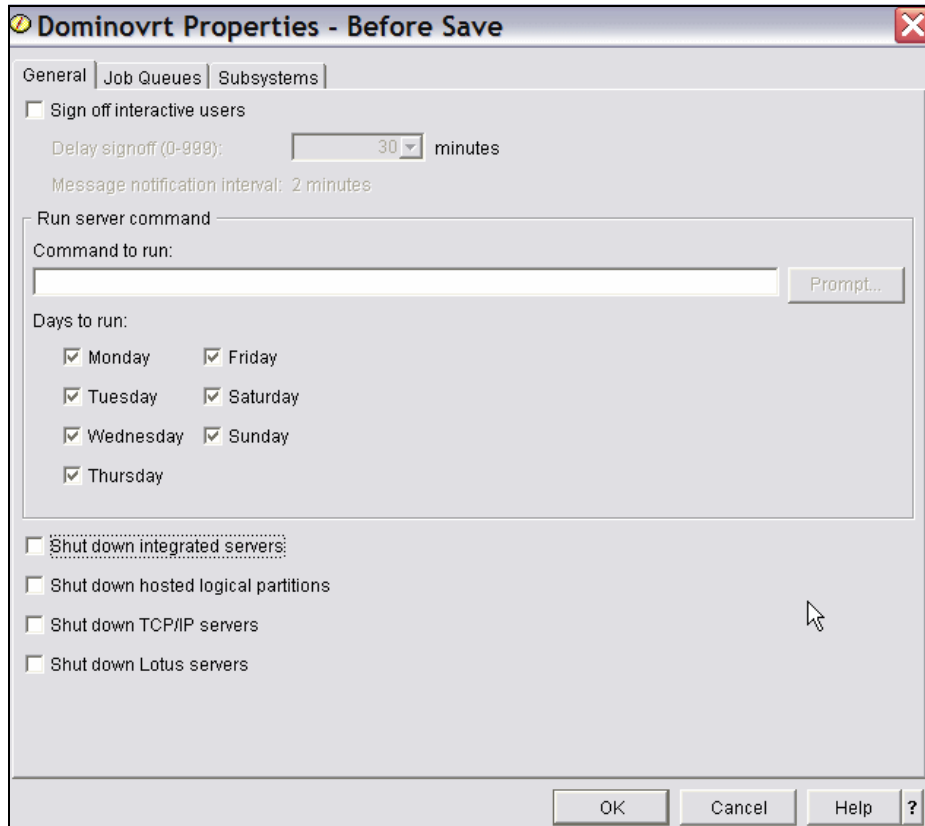

Figure 5-58 BRMS move policy change, Before Save - General tab

5. Click **During** in the Properties window shown in Figure 5-59 on page 245.

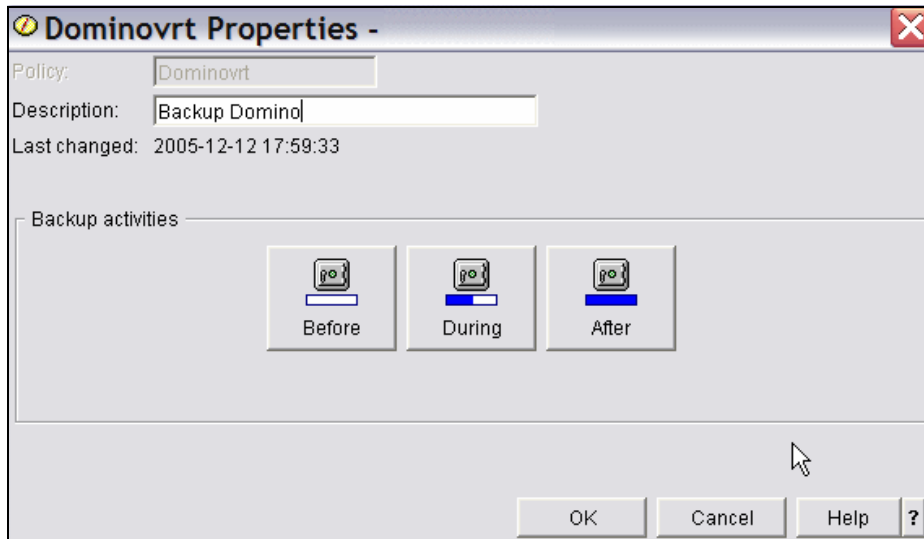

Figure 5-59 BRMS move policy change, select During

6. In the During Save window shown in Figure 5-60 on page 246, click the **What** tab, make sure that no user defined file systems are unmounted, and then click the **Where** tab.

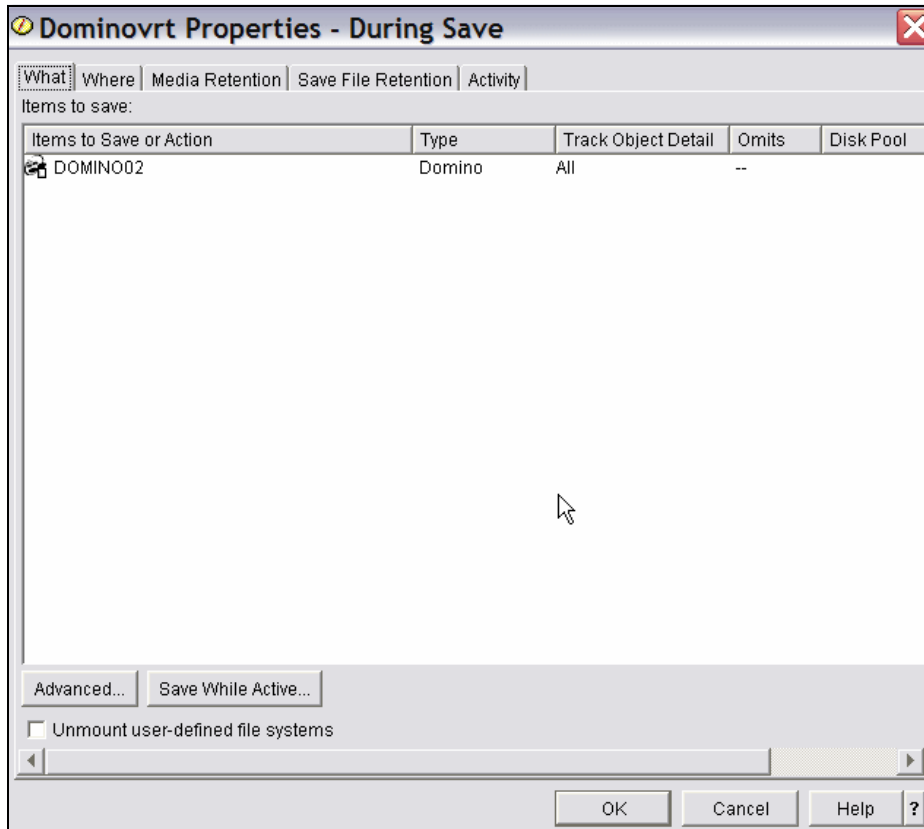

Figure 5-60 BRMS move policy change, During - What tab

7. Click **Advanced** in the window shown in Figure 5-61 on page 247.

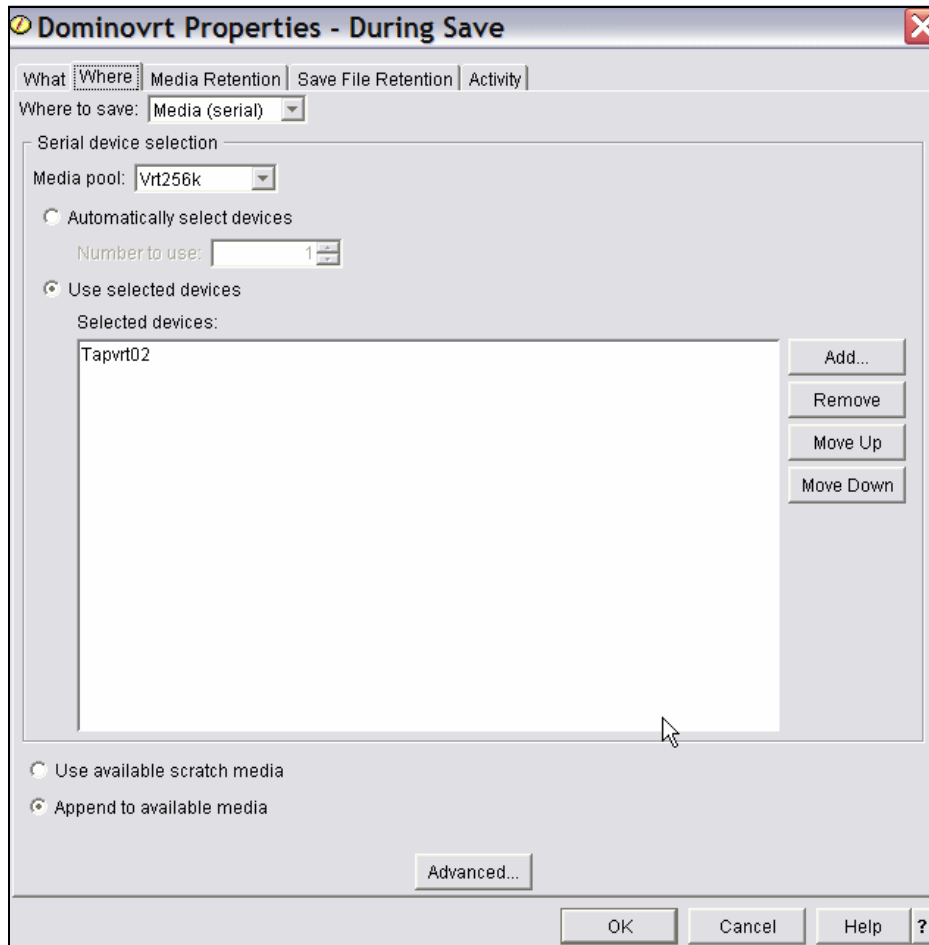

Figure 5-61 BRMS move policy change, during - what tab - advanced

8. In the Advanced Properties window shown in Figure 5-62 on page 248, select **Mark saved items for duplication**, for both Full and Changes only. Select **Dominodup** against Move Policy for both Full and Changes only. If you want to prohibit other users from reading these volumes, select the corresponding field. Click **OK** when done.

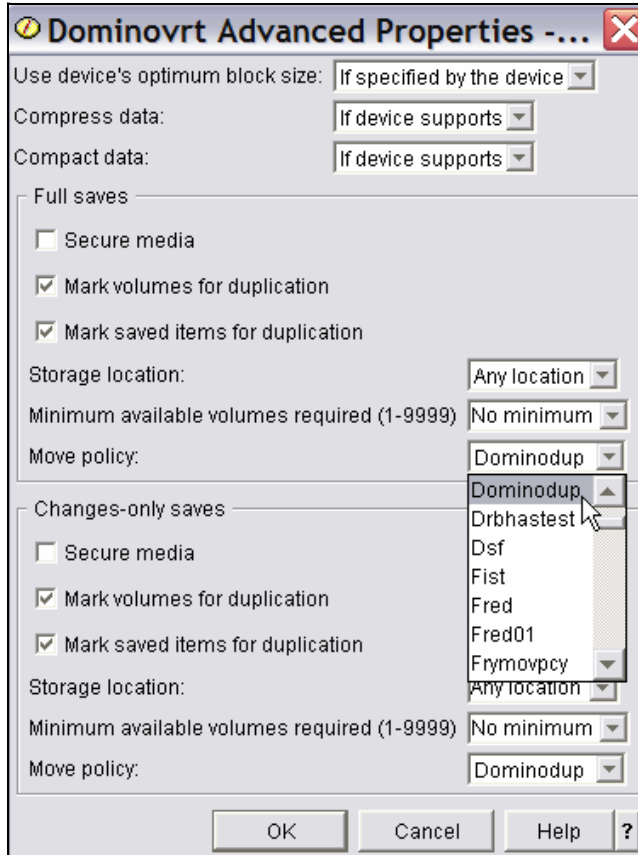

Figure 5-62 BRMS move policy change, During - What - Advanced Properties

9. Leave the During Save panel Figure 5-61 on page 247 by clicking **OK**.
10. In the Properties window (shown in Figure 5-59 on page 245), click **After**.
11. Then, in the window shown in Figure 5-63 on page 249, deselect **Start integrated servers**, scroll down **Save media information** and select **Objects**, and click **OK**.

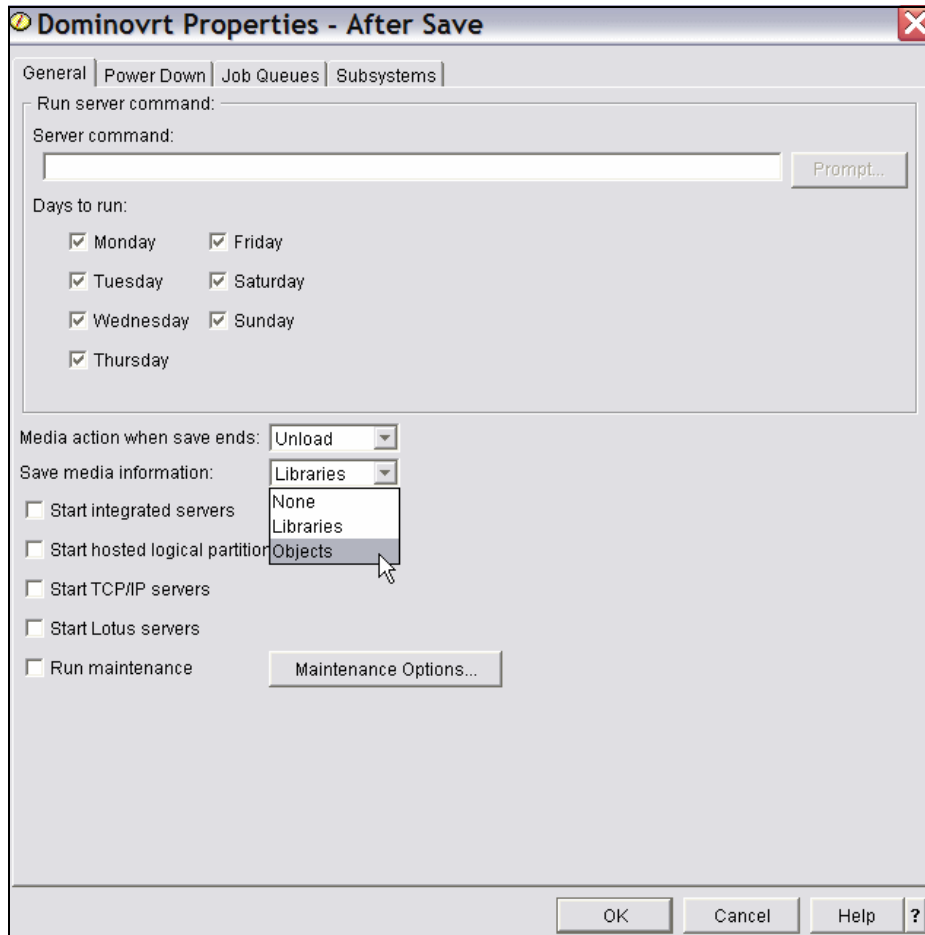

Figure 5-63 BRMS move policy change, After Save - General tab

12. Since there are no more changes, click **OK** in the Properties window shown in Figure 5-64 on page 250.

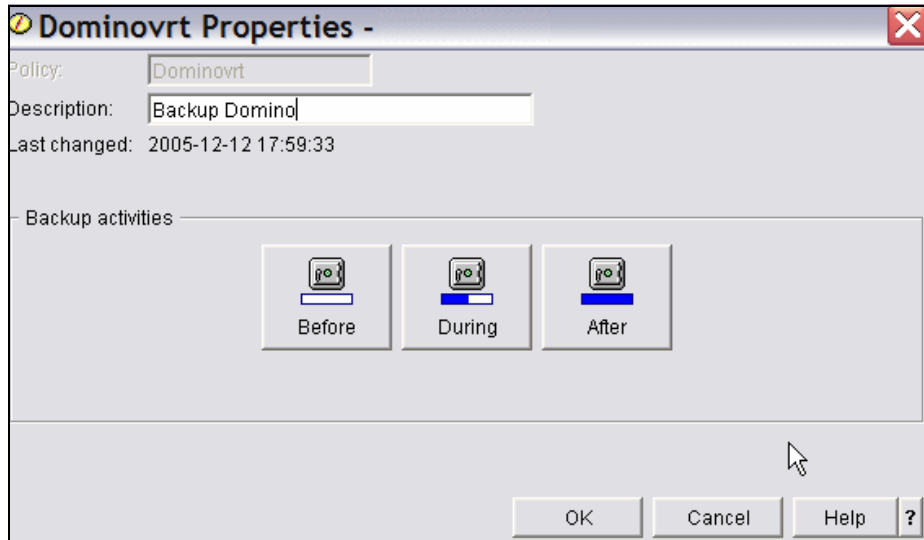

Figure 5-64 BRMS move policy change, Before-During-After Save window

The backup policy is now ready to go live.

## 5.5 Running the Domino backup

To execute the backup policy, perform the following tasks:

1. Right-click the Backup policy Dominovrt and select **Run Now**, as shown in Figure 5-65 on page 251.

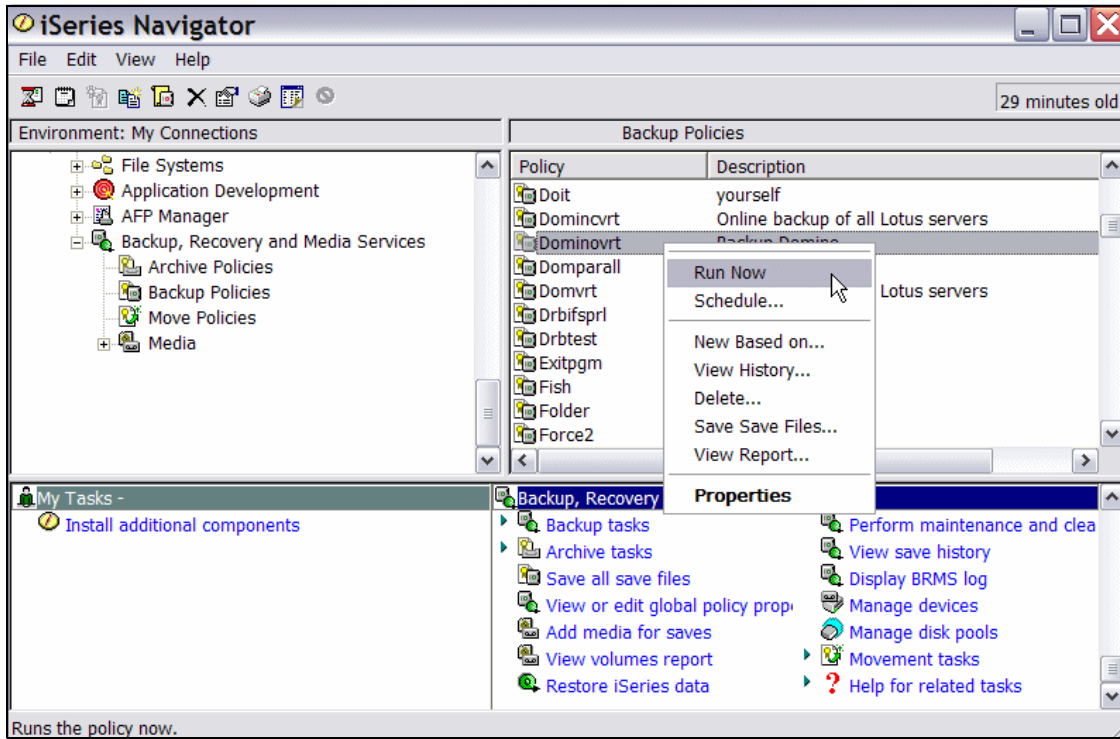

Figure 5-65 BRMS run Domino backup, Run Now selected

2. Since there are no backup overrides, click **OK** in the window shown in Figure 5-66 on page 252.

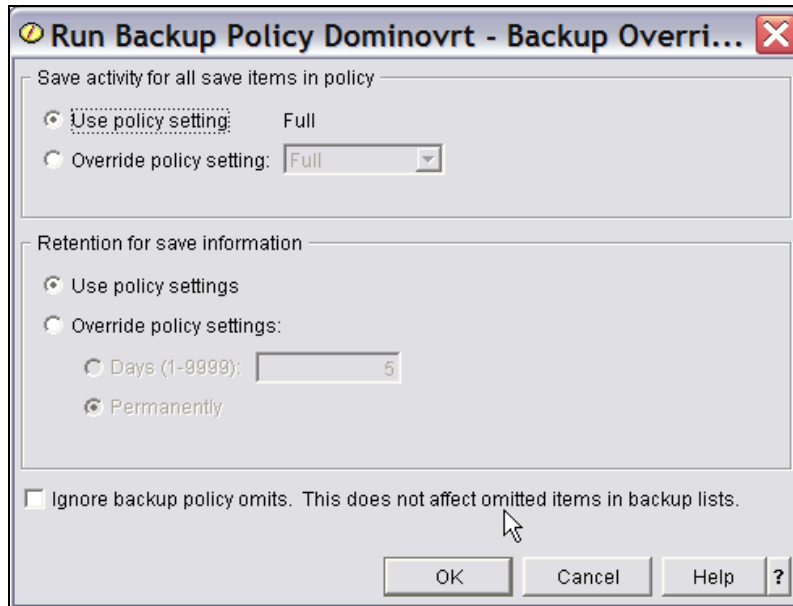

Figure 5-66 BRMS run Domino backup, overrides

3. Click **OK** in the window shown in Figure 5-67, and wait until the connection to the central system is complete.

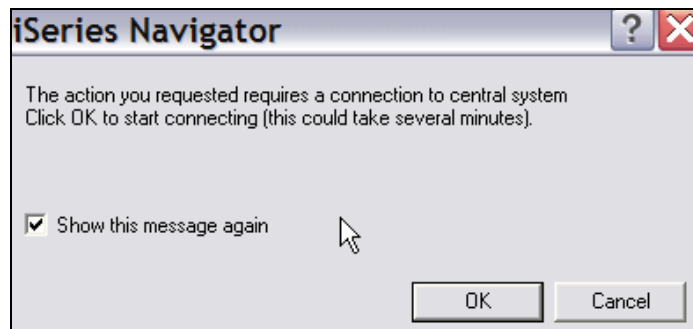

Figure 5-67 BRMS run Domino backup

4. In the window shown in Figure 5-68 on page 253, select **Save task output...**, and then click **OK**.

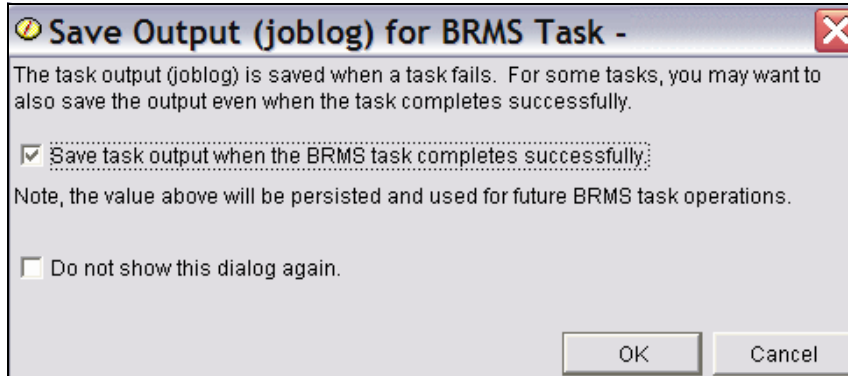

Figure 5-68 BRMS run Domino backup, save joblog

5. The save job is started in the window shown in Figure 5-69. Click **OK**.

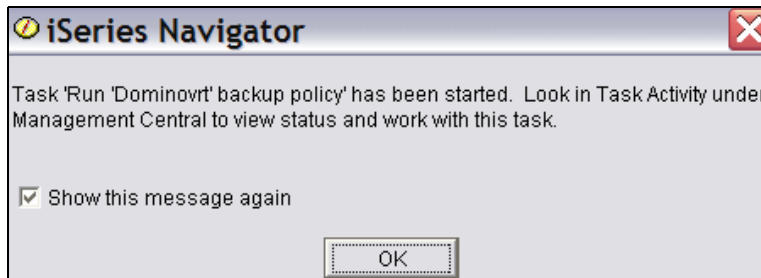

Figure 5-69 BRMS run Domino backup, job started

6. Figure 5-70 shows that the job is completed.

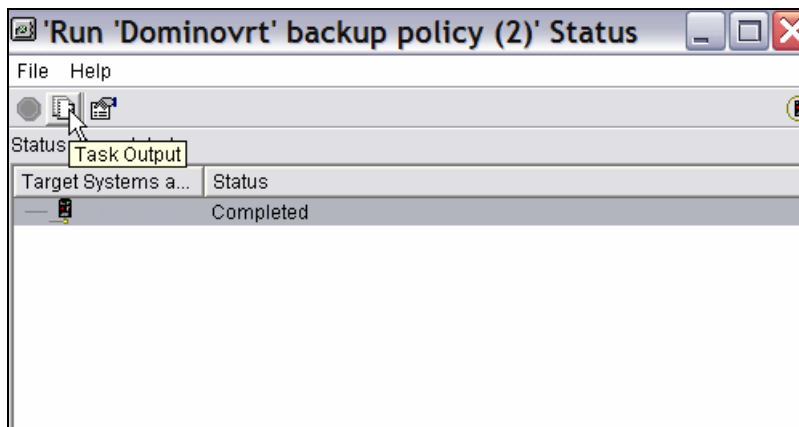
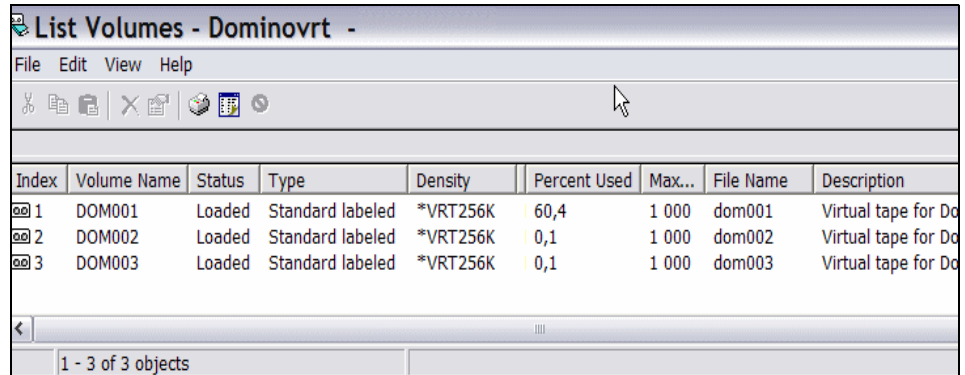

Figure 5-70 BRMS run Domino backup, job completed

7. Figure 5-71 shows the volumes after the backup is complete. It shows that it used 60% of one volume.



Index	Volume Name	Status	Type	Density	Percent Used	Max...	File Name	Description
1	DOM001	Loaded	Standard labeled	*VRT256K	60,4	1 000	dom001	Virtual tape for Do
2	DOM002	Loaded	Standard labeled	*VRT256K	0,1	1 000	dom002	Virtual tape for Do
3	DOM003	Loaded	Standard labeled	*VRT256K	0,1	1 000	dom003	Virtual tape for Do

1 - 3 of 3 objects

Figure 5-71 BRMS run Domino backup, list volumes after job is complete

## 5.5.1 Checking the results

To check the results, perform the following tasks:

1. Click the **Task Output** icon; see Figure 5-72. The listings from the job are shown.

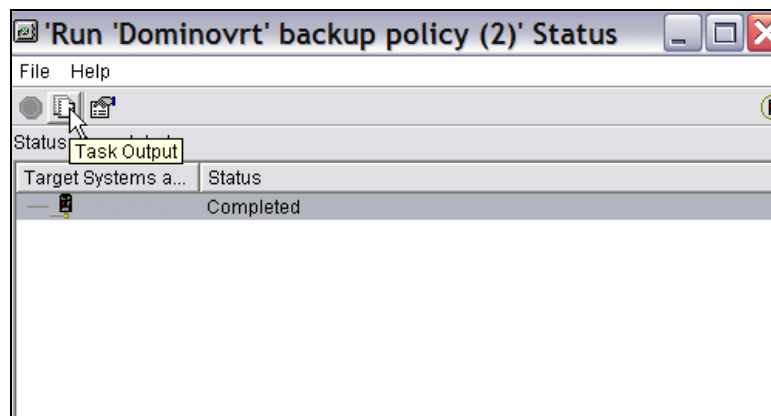

Figure 5-72 BRMS run Domino backup, job completed

2. To check the joblog, select **Qpjoblog** and double-click, as shown in Figure 5-73 on page 255.

File Name	User-specified Data	User	Status	Output Queue	Output
Qpjoblog	QZRCRSVS	Quser	Ready to print	Qezjoblog	Qusr

1 - 1 of 1 objects

Figure 5-73 BRMS run Domino backup, printer output

Figure 5-74 on page 256 shows an example of the joblog. Among other things, it tells how many objects were saved.

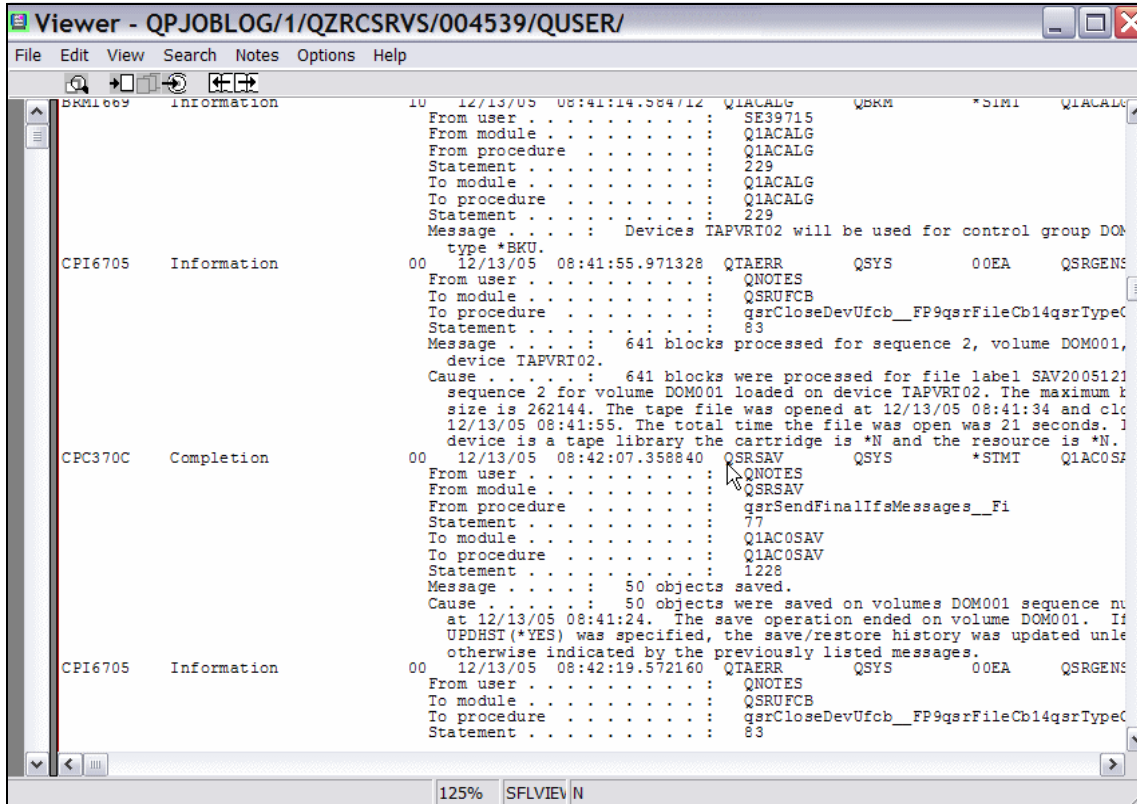

Figure 5-74 BRMS run Domino backup, joblog

3. After you read through the joblog, close it.
4. To check the BRMS log, go to the Management Central section of the i5 Navigator.

Right-click the backup and select **BRMS Log**, as shown in Figure 5-75 on page 257. BRMS automatically fills in the parameters related to that job.

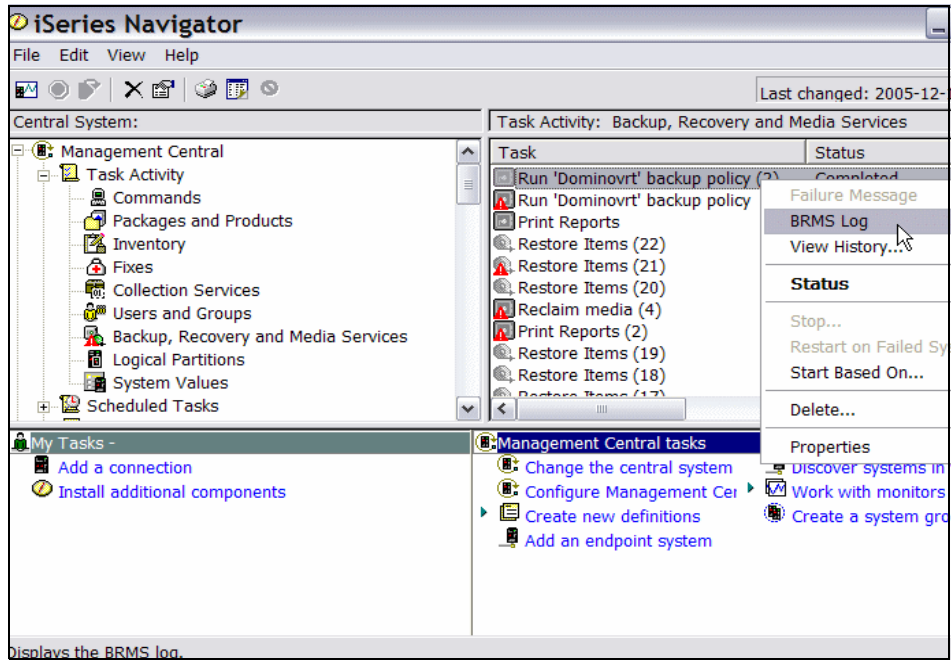

Figure 5-75 BRMS run Domino backup, selecting BRMS log

5. In the BRMS Log Include Entry type shown in Figure 5-76 on page 258, select **Backup**.

Change the date to Current date only, and change the time, if needed. Click **OK**.

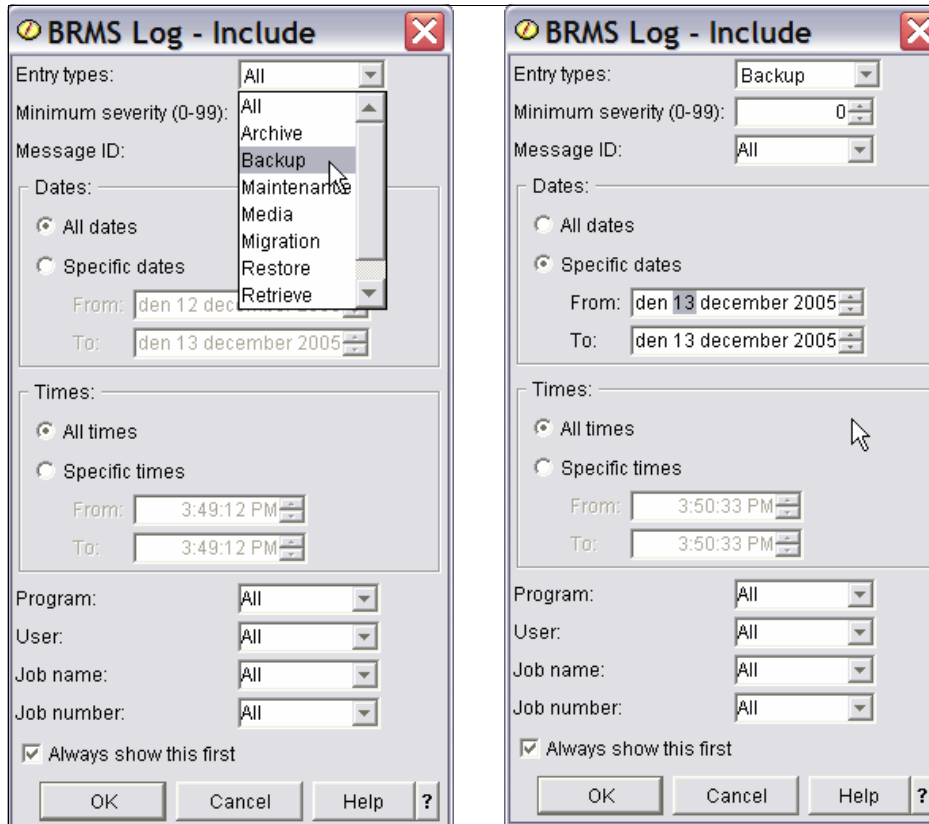

Figure 5-76 BRMS run Domino backup, select entries from BRMS log

Figure 5-77 on page 259 displays the results.

BRMS Log -							
File Edit View Help							
Entry types: Backup Date Sent: 2005-12-13 - 2005-12-13							
Message ID	Sev...	Entry T...	Message	Date Sent	Time S...	User	Job Name
Brm1380	10	Backup	Begin processing for control gr...	2005-12-13	08:41:14	Se39715	Qzrcsrvs
Brm1669	10	Backup	Devices TAPVRT02 will be use...	2005-12-13	08:41:14	Se39715	Qzrcsrvs
Brm1413	0	Backup	Starting save of list *SAVBRM ...	2005-12-13	08:41:23	Qnotes	Qzrcsrvs
Brm1414	0	Backup	Save of list *SAVBRM complete.	2005-12-13	08:42:09	Qnotes	Qzrcsrvs
Brm1413	0	Backup	Starting save of list *SAVBRM ...	2005-12-13	08:42:15	Qnotes	Qzrcsrvs
Brm1414	0	Backup	Save of list *SAVBRM complete.	2005-12-13	08:42:22	Qnotes	Qzrcsrvs
Brm1413	0	Backup	Starting save of list *SAVBRM ...	2005-12-13	08:42:27	Qnotes	Qzrcsrvs
Brm1414	0	Backup	Save of list *SAVBRM complete.	2005-12-13	08:42:52	Qnotes	Qzrcsrvs
Brm1413	0	Backup	Starting save of list *SAVBRM ...	2005-12-13	08:42:59	Qnotes	Qzrcsrvs
Brm1414	0	Backup	Save of list *SAVBRM complete.	2005-12-13	08:43:02	Qnotes	Qzrcsrvs
Brm1647	10	Backup	Starting save of media inform...	2005-12-13	08:43:03	Se39715	Qzrcsrvs
Cpc3701	20	Backup	15 objects saved from library ...	2005-12-13	08:43:30	Se39715	Qzrcsrvs
Brm1587	10	Backup	Save of BRM media informatio...	2005-12-13	08:43:31	Se39715	Qzrcsrvs
Brm1049	0	Backup	Control group DOMINOVRT typ...	2005-12-13	08:43:33	Se39715	Qzrcsrvs

90 - 103 of 103 objects

Figure 5-77 BRMS run Domino backup, BRMS log

6. To check the backup history, go to the Management Central section of i5 Navigator.

Right-click the backup and select **View History**, as shown in Figure 5-78 on page 260.

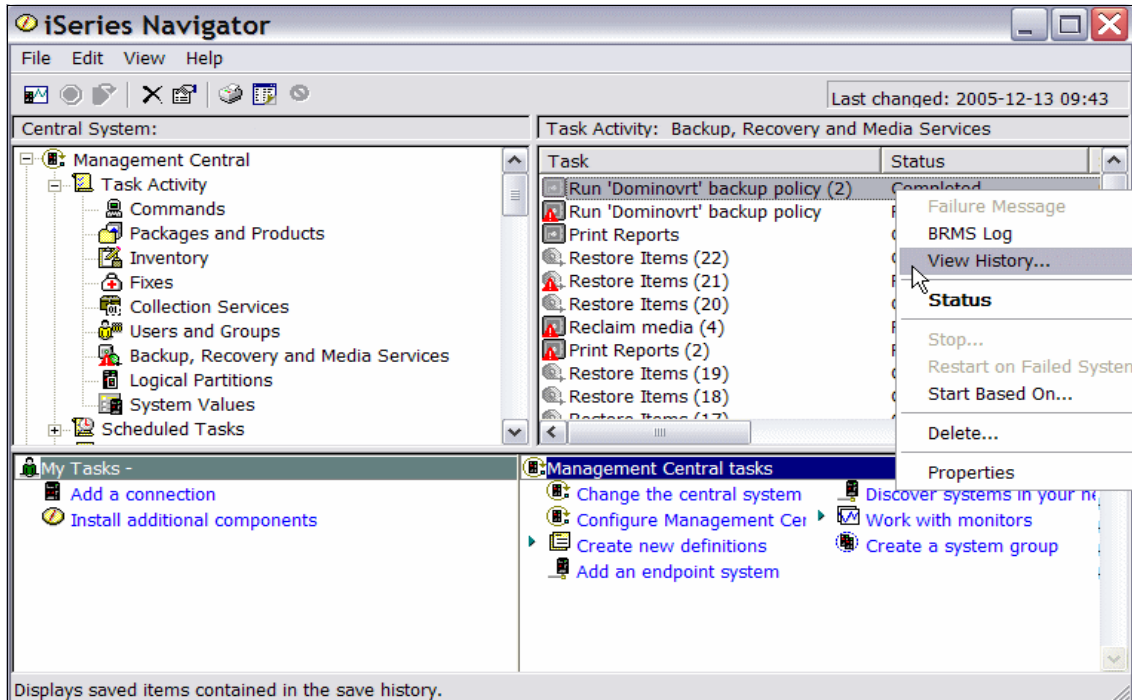

Figure 5-78 BRMS run Domino backup, View History selected

7. Figure 5-79 on page 261 shows that the values in backup policy are already filled in. Click **OK**.

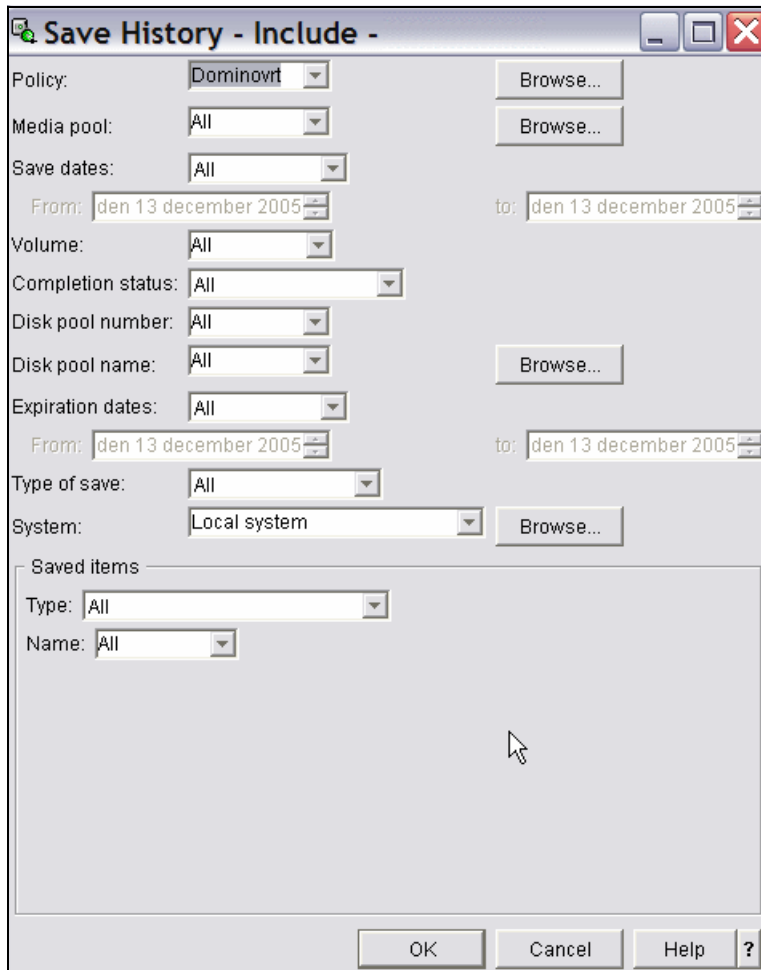
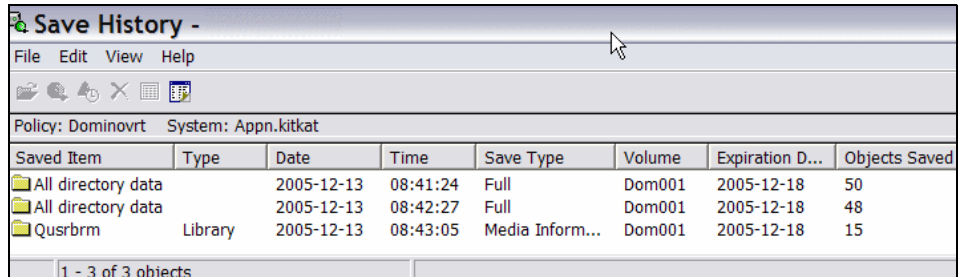

Figure 5-79 BRMS run Domino backup, select entries from BRMS history log

BRMS presents the backup history for the job where you can see, for example, the number of objects that were saved; see Figure 5-80.



The screenshot shows a window titled "Save History -" with a menu bar (File, Edit, View, Help) and a toolbar. Below the toolbar, it displays "Policy: Dominovrt" and "System: Appn.kitkat". The main area contains a table with the following data:

Saved Item	Type	Date	Time	Save Type	Volume	Expiration D...	Objects Saved
All directory data		2005-12-13	08:41:24	Full	Dom001	2005-12-18	50
All directory data		2005-12-13	08:42:27	Full	Dom001	2005-12-18	48
Qusrbrm	Library	2005-12-13	08:43:05	Media Inform...	Dom001	2005-12-18	15

At the bottom of the table, it says "1 - 3 of 3 objects".

Figure 5-80 BRMS run Domino backup, BRMS history log

This concludes the processes involved in running a Domino backup.

## 5.6 Restoring a mail file

In this scenario, we restore a mail file named mail6.ntf. Follow these steps to duplicate the tasks:

1. In Backup, Recovery and Media Services Tasks, click the **Restore iSeries data** icon, as shown in Figure 5-81 on page 263.

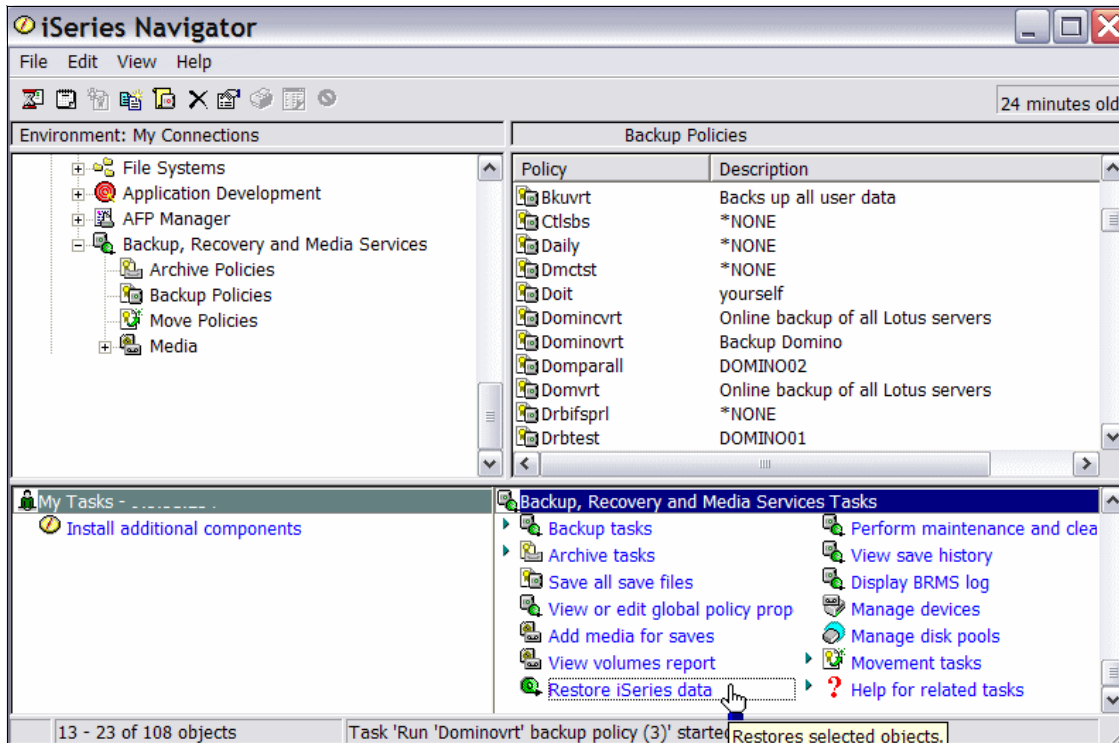

Figure 5-81 Restore Domino data with BRMS, restore icon

2. Read through the information screen that pops up as shown in Figure 5-82, and click **OK**.

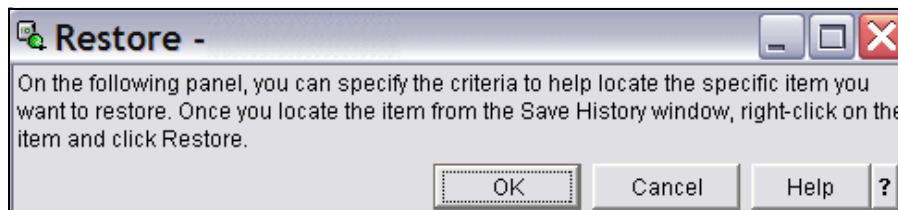

Figure 5-82 Restore Domino data with BRMS, restore information

3. In the Include window shown in Figure 5-83 on page 264, fill in the values pertaining to the policy to be restored and the corresponding dates.  
As an alternative, you can click **Browse** to find the policy.

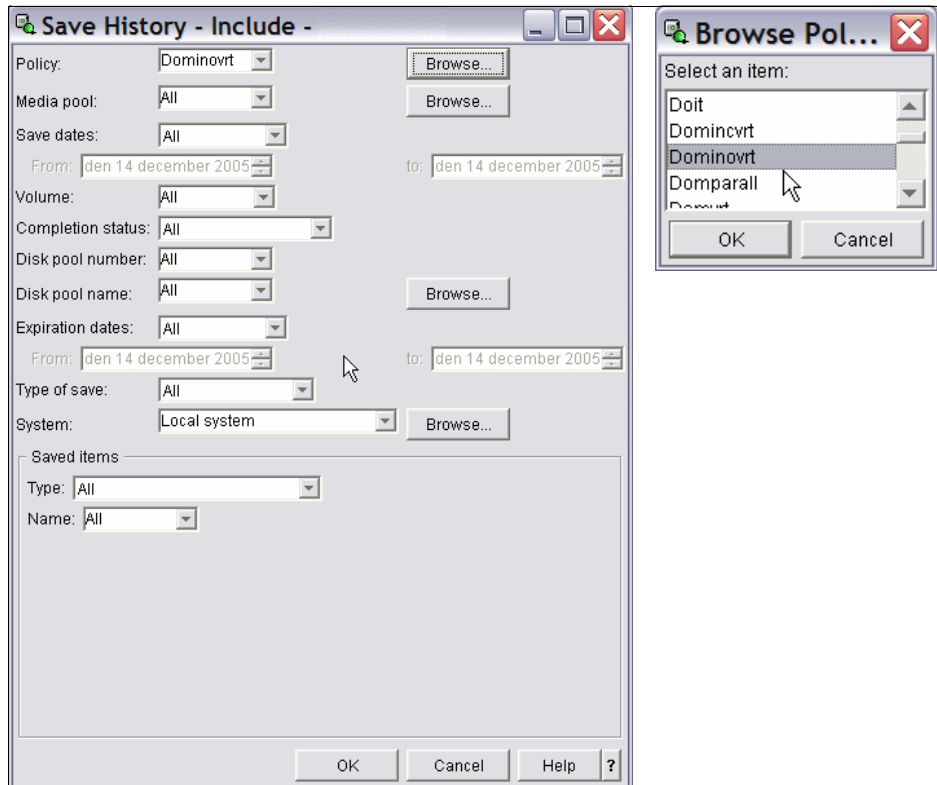

Figure 5-83 Restore Domino data with BRMS, Save History Include

- In the Save History window shown in Figure 5-84 on page 265, right-click the relevant joblog and select **Open**.  
As an alternative, you can use the **Open** icon in the navigation bar.

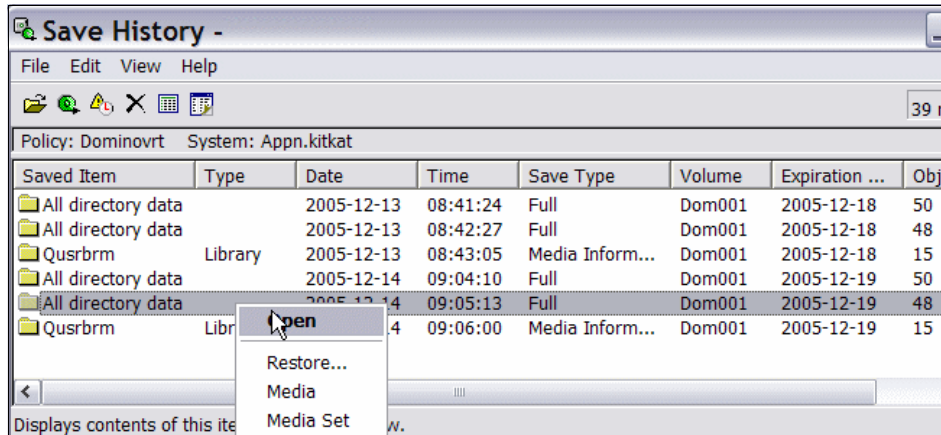

Figure 5-84 Restore Domino data with BRMS, Save History - select

5. Right-click the relevant saved record item and select **Open**, as shown in Figure 5-85.

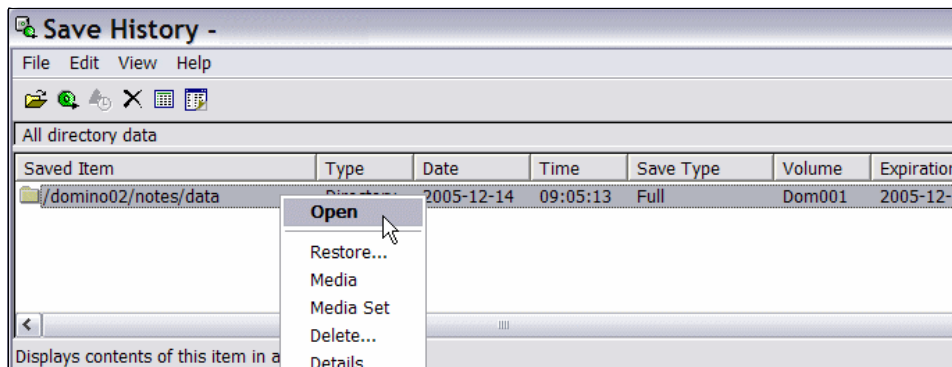

Figure 5-85 Restore Domino data with BRMS, Save History - open file for restore

6. This brings up all 48 objects that were saved in that portion of the save, as shown in Figure 5-86 on page 266.

Right-click the save record presented and select **Restore....**

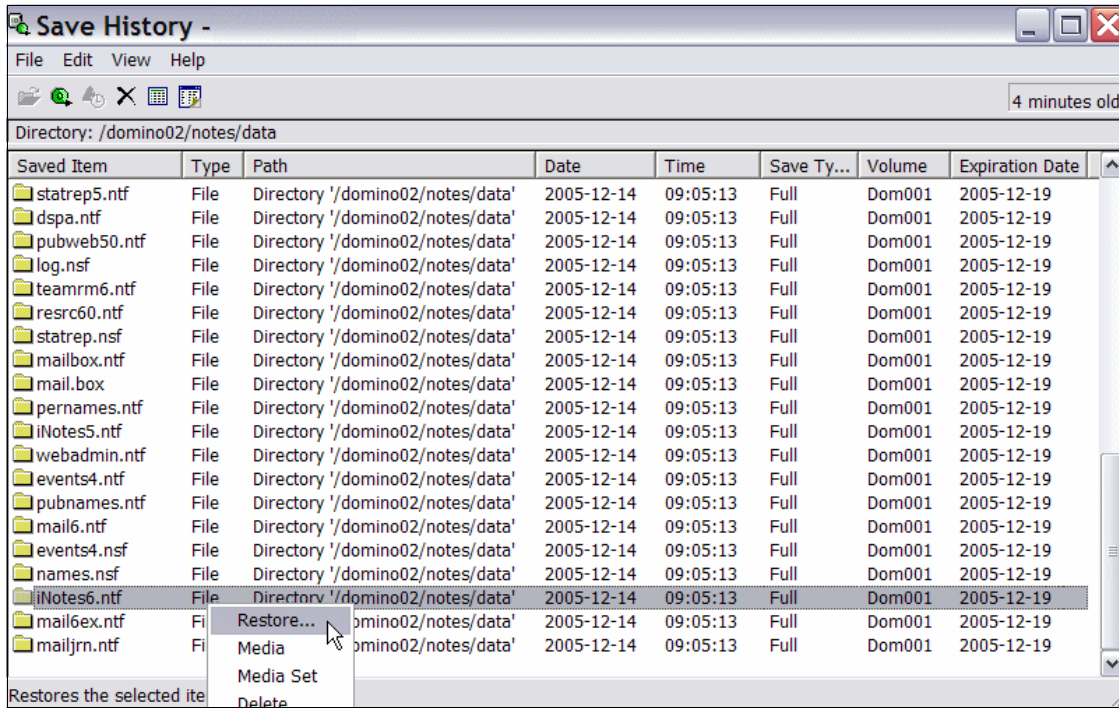

Figure 5-86 Restore Domino data with BRMS, Save History - select object to restore

**Note:** The number of Domino objects that are saved in each sub-save is defined in Domino. In this example system, it is 50. Contact your Notes administrator if this value does not suit your needs.

The parameter is found in the notes.ini file. If not specified, the default value is 50.

7. Read through the Restore window shown in Figure 5-87 on page 267, and click **Next**.

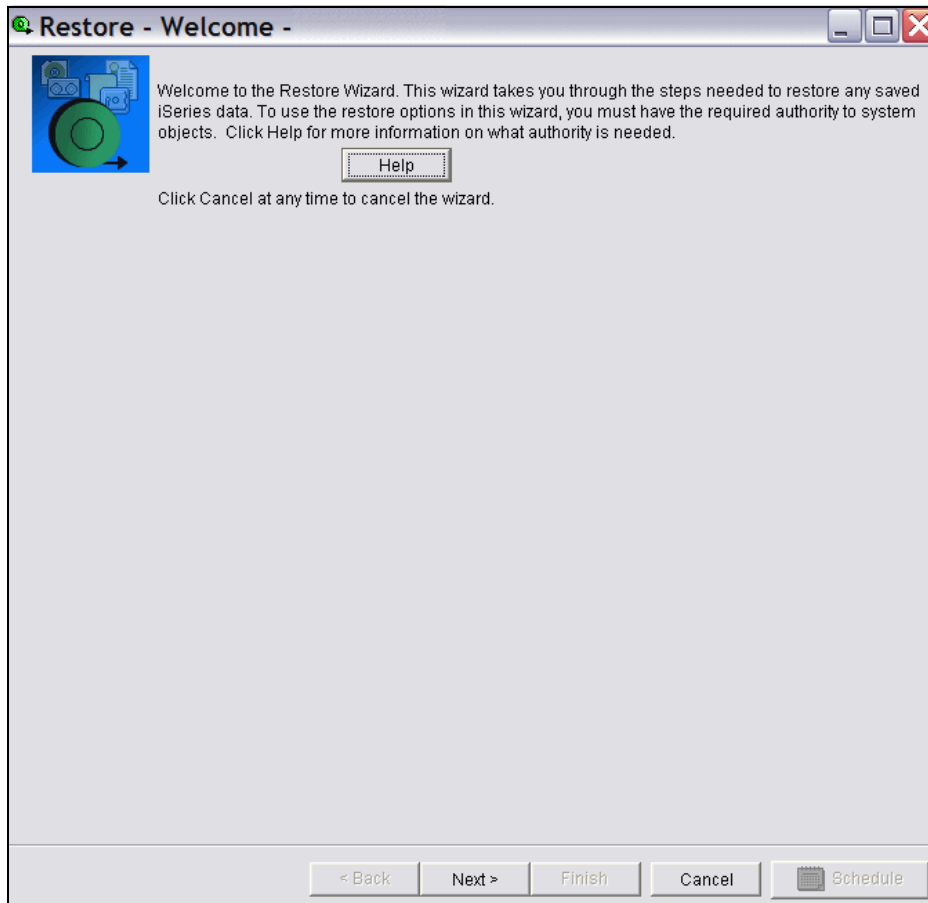

Figure 5-87 Restore Domino data with BRMS, Welcome panel

8. In the window shown in Figure 5-88 on page 268, select **Yes, use same name**, and click **Next**.

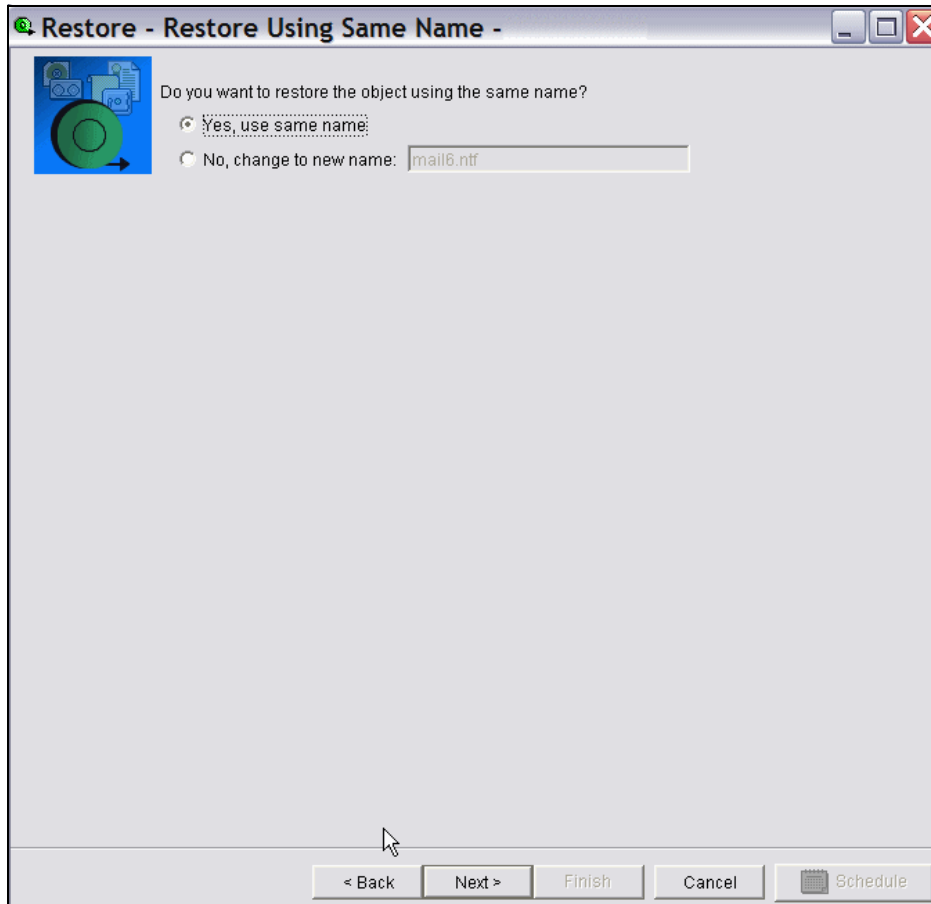

Figure 5-88 Restore Domino data with BRMS, Restore - same name

9. In the window shown in Figure 5-89 on page 269, select **Yes, restore to the same location**, and click **Next**.

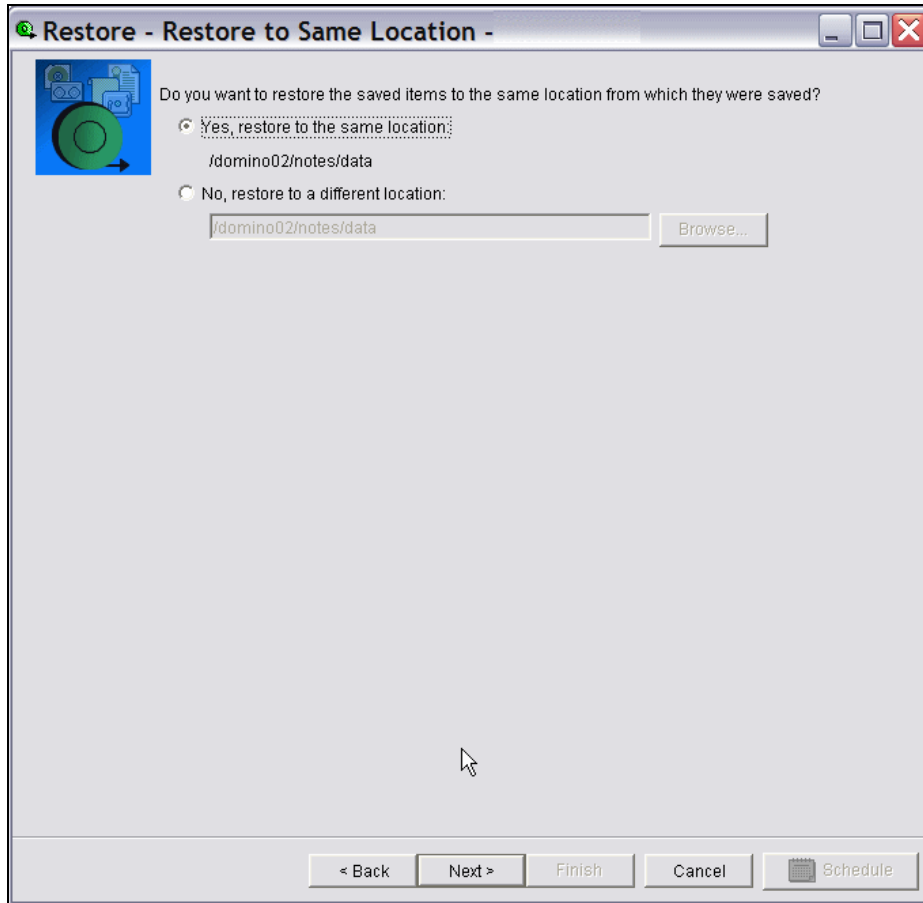

Figure 5-89 Restore Domino data with BRMS, Restore - same location

10. Before deciding on the tape device to use, ensure that the volumes containing the backup to restore are loaded.

Select the relevant tape drive, and click **Add Before** or **Add After**, as shown in Figure 5-90 on page 270.

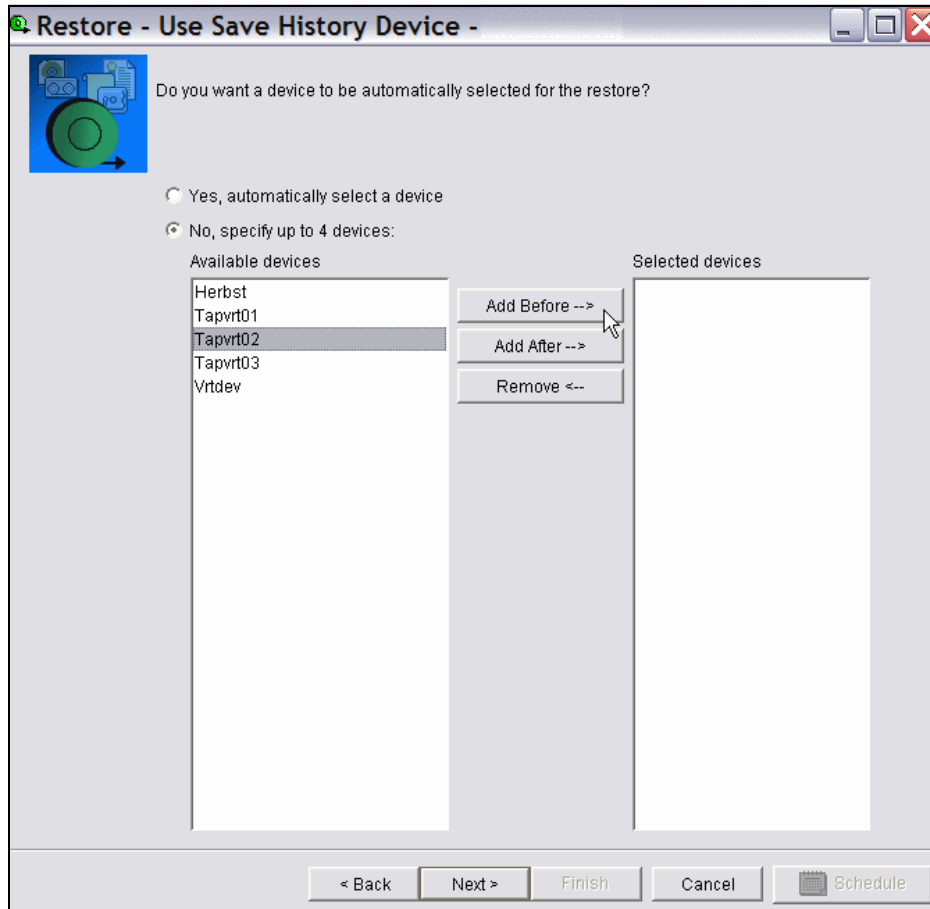

Figure 5-90 Restore Domino data with BRMS, Restore - select tape device

11. The tape drive is selected. Click **Next** as shown in Figure 5-91 on page 271.

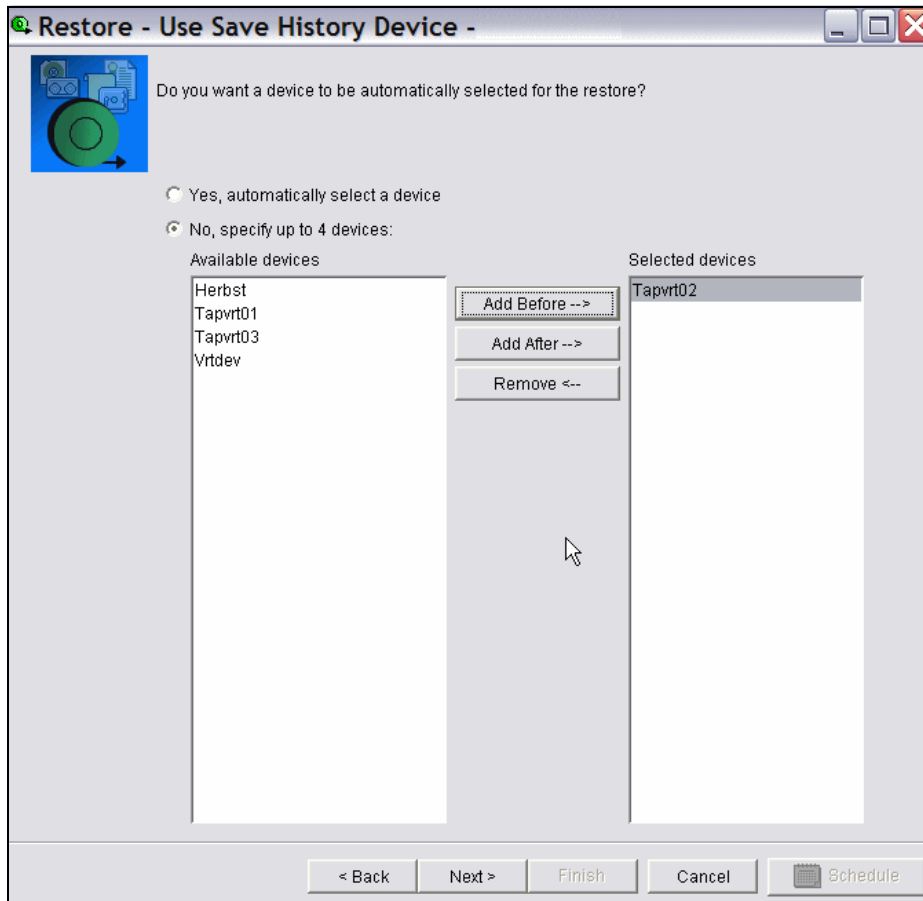

Figure 5-91 Restore Domino data with BRMS, Restore - tape device selected

12. In the Restore Summary window shown in Figure 5-92 on page 272, click **Advanced Options...** and the selection panel shown in Figure 5-93 on page 273 will open.

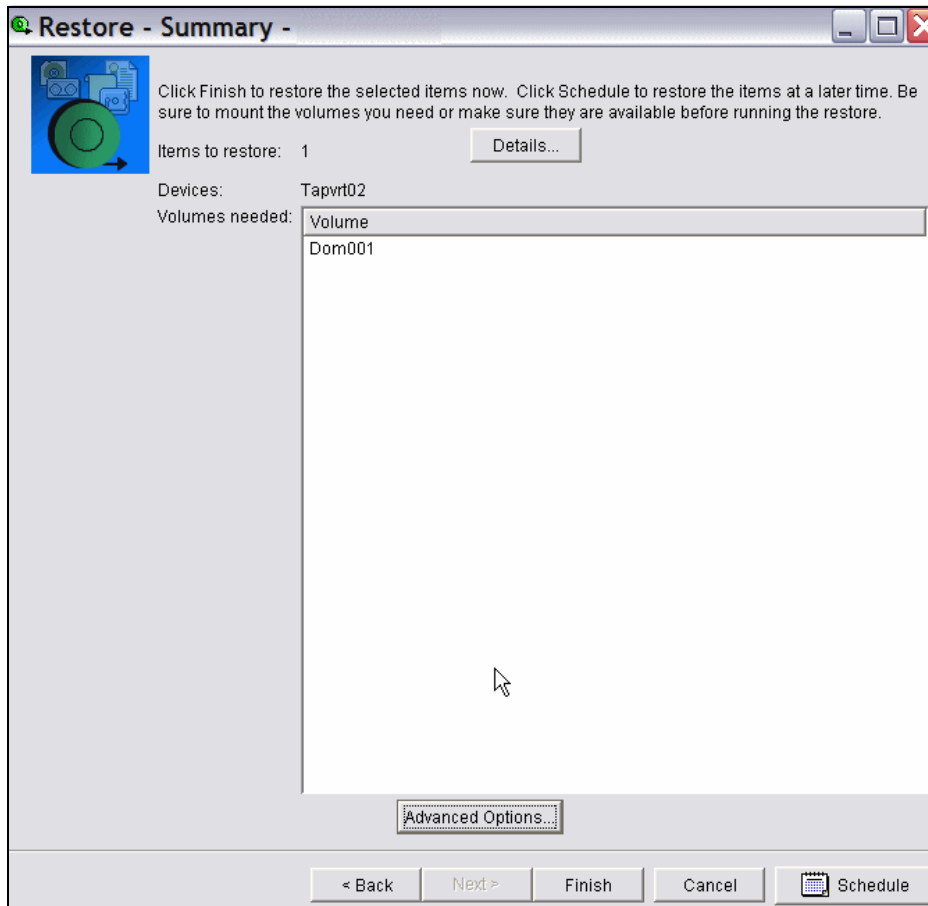

Figure 5-92 Restore Domino data with BRMS, Restore summary

13. This offers additional printing, selection, and tape actions. If you want to allow differences, create parent directories, or change the end of tape option (the default is rewind), click the radio button or pull-down menu as appropriate. Then click **Finish** if you make changes. Otherwise, click **Cancel**.

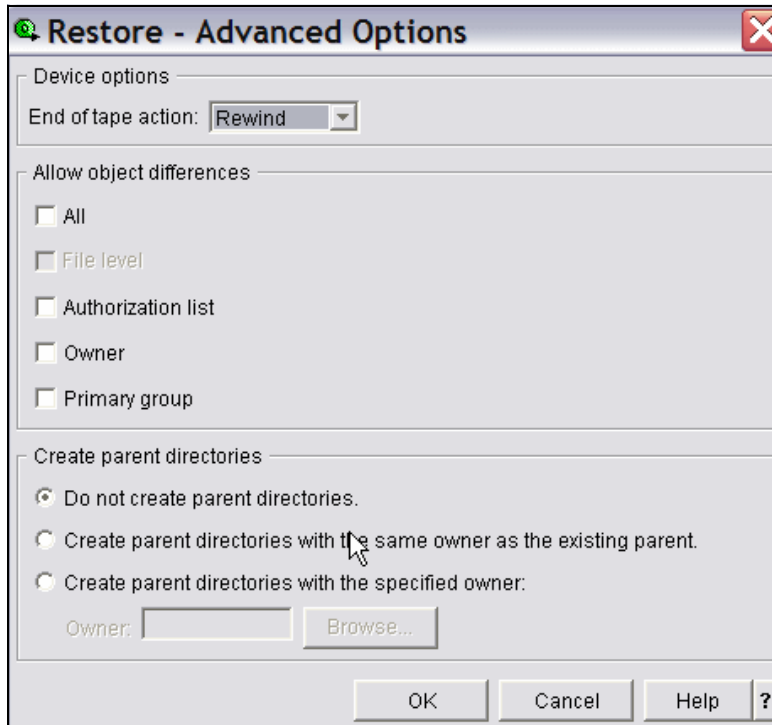

Figure 5-93 Restore Domino data with BRMS, Restore summary - advanced

14. In the Restore Summary panel shown in Figure 5-94 on page 274, click **Finish**.

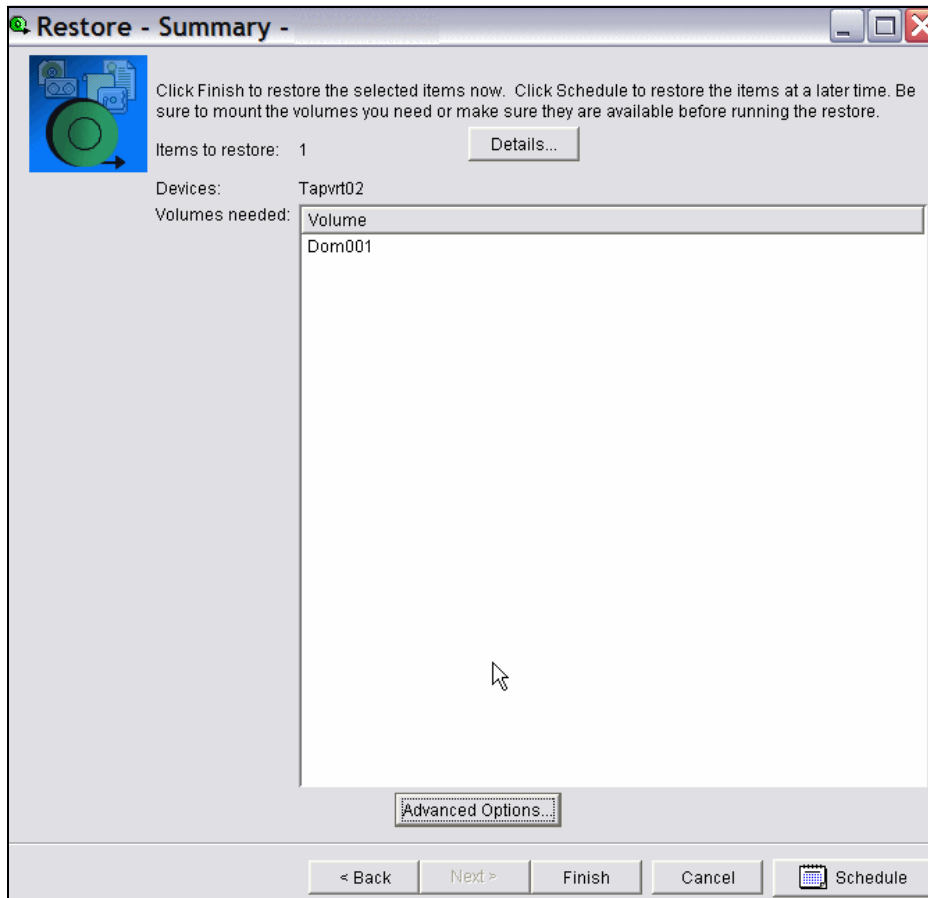

Figure 5-94 Restore Domino data with BRMS, Restore summary - Finish

15. If you want the joblog to be saved, select **Save task output...** and click **OK**, as shown in Figure 5-95 on page 275.

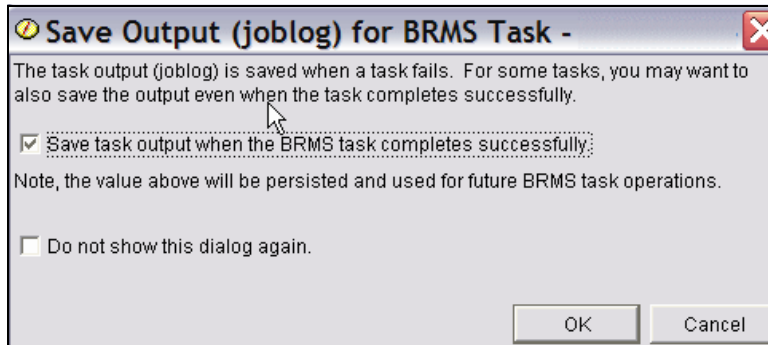

Figure 5-95 Restore Domino data with BRMS, Restore - save joblog

16. Figure 5-96 shows that the Restore Items task is started. Click **OK**.

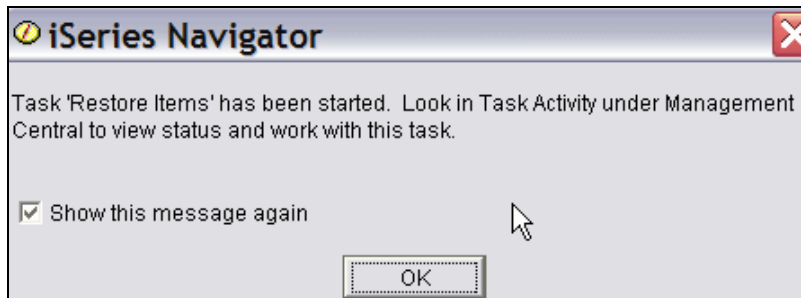

Figure 5-96 Restore Domino data with BRMS, Restore started

Figure 5-97 shows that the restore job is completed.

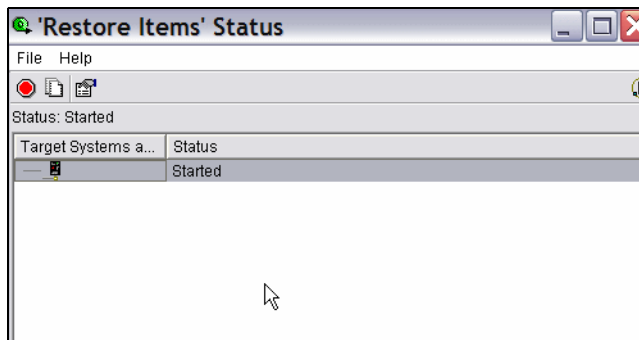

Figure 5-97 Restore Domino data with BRMS, Restore completed

## 5.6.1 Checking the results

To check the results, perform the following tasks:

1. Open the joblog by clicking the **Task Output** icon, as shown in Figure 5-98.

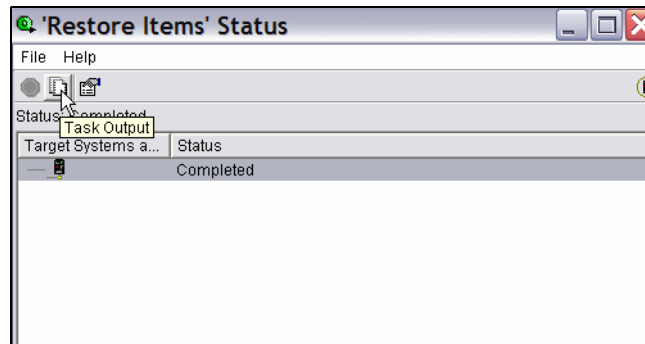

Figure 5-98 Restore Domino data with BRMS, restore - Task Output

2. Double-click the joblog shown in Figure 5-99, or select the joblog and click the **Open** icon.

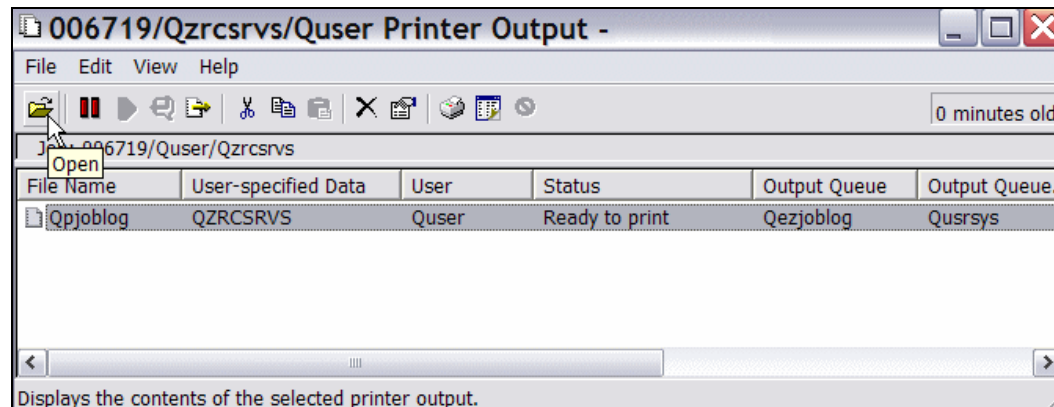

Figure 5-99 Restore Domino data with BRMS, Restore - open joblog

3. Figure 5-100 on page 277 shows the joblog. Scroll down until you find a LNT0962 message stating Recovery of following Domino database completed successfully: /domino02/notes/data/mail6.ntf.

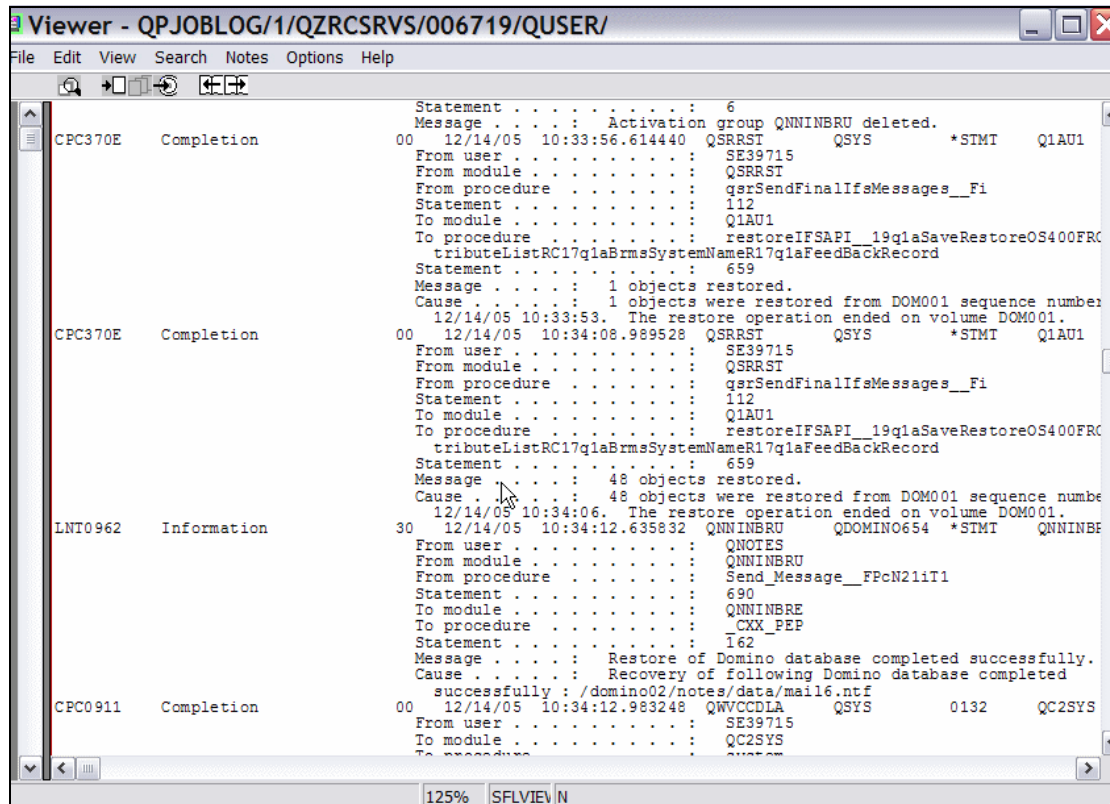

Figure 5-100 Restore Domino data with BRMS, Restore - joblog

To understand the message better, refer to the following Web site:

<http://www-03.ibm.com/servers/eserver/series/service/brms/domsingledb.html>

Its opening page is shown in Figure 5-101 on page 278.

Country/region [select] Terms of use

Home Products Services & solutions Support & downloads My account

Servers > Midrange servers > BRMS >

## How to recover a single Lotus database

Use the RSTBRM command to recover a specific Lotus Server database. For example, to restore a Domino database called 'catalog' from the device TAP01, you would simply enter the following command:

```
RSTBRM DEV(TAP01) OBJ('/notes/data/catalog.nsf')
```

**NOTE:** You do not need to specify the media identifier on RSTBRM because BRMS knows what media contains the most current version of the data and will ask a system operator if the media is not currently loaded in TAP01.

After the recovery completes, review the job log to ensure that the recovery was successful. To display the job log, enter the following command:

```
DSPJOBLOG
```

On the display, press F10 and page up to see the details of any messages that were logged during recovery processing.

**NOTE:** Multiple objects are associated with a notes database when it is backed up while online; therefore, multiple messages will appear during recovery. For example, if you had the databases set to groups of 5, you would see the following messages:

```
1 objects restored.
5 objects restored.
Restore of Domino database completed successfully.
```

**NOTE:** If this saved item was saved using an incremental backup, BRMS will restore the transactional logs and the database all in this one command.

**NOTE:** By default, the Domino API to recover a database will delete any database with the same name in the same location as the database being restored. To avoid any problems that could be caused by this deletion, restore the database to a different server or to a different subdirectory under the same server. Then, after verifying that the restored database is correct, use the Domino interfaces to move the recovered documents back to the original database or use the Domino interfaces to delete the original database and replace it with the recovered database.

**Related links**

- iSeries Storage
- Hierarchical Storage Management (HSM)
- Tivoli Storage Manager
- Lotus Domino
- iSeries Navigator

Figure 5-101 Restore Domino data with BRMS, Restore - recover single Lotus database

In the joblog you can also see two CPC370E messages. The first message states 1 object restored and the second message states 48 objects restored, although only one object is restored. This is because of the way the data is laid out.

This is *not* what you will see for ordinary i5 data. These files are specially adopted for Domino. Some are even hidden. You will not see them in the inventory. You only notice that some sequence numbers are missing.

4. Close the joblog and other opened windows related to this task.

This concludes the restore of the mail file mail6.ntf.



## BRMS and virtual tape

In this chapter we describe how to use virtual tape within BRMS. We assume that virtual tape is already set up as described in Chapter 3, “Implementing virtual tape storage” on page 33.

The virtual tape devices, image catalog, and virtual volumes must be created before implementing virtual tape with BRMS.

This chapter distinguishes between IBM @server iSeries Navigator and 5250 emulation, since the approach for BRMS is totally different and it may be confusing when combining them. Here we cover only BRMS using 5250 emulation. BRMS and virtual tape using IBM @server iSeries Navigator is covered separately in Chapter 7, “BRMS and virtual tape working from the Navigator” on page 329.

The topics covered in this chapter include how to implement BRMS using 5250 emulation, how to set up virtual tape, installing and maintaining BRMS, and setting up locations in BRMS for virtual tape.

## 6.1 Implementing BRMS using 5250 emulation

Before you implement BRMS, set up the environment for virtual tape.

**Note:** In this chapter we describe only the basic steps for setting up virtual tape as required for BRMS. For a complete explanation covering all the options for setting up virtual tape, refer to Chapter 3, “Implementing virtual tape storage” on page 33.

## 6.2 Setting up virtual tape

If you have already created the virtual tape devices, image catalog, and virtual volumes, skip the following steps and proceed with the 6.3, “Installing BRMS” on page 281.

Perform the following actions to set up a virtual tape:

1. Create a virtual tape device or devices.

To create a virtual tape device, enter the following command:

```
CRTDEVTAP DEVD(TAPVRT01) RSRNAME(*VRT)
```

You can also create an additional tape device, which will be used later for parallel backup:

```
CRTDEVTAP DEVD(TAPVRT02) RSRNAME(*VRT)
```

2. Vary on the tape device or devices.

After creating the devices, enter the following commands to vary them on:

```
VRYCFG CFGOBJ(TAPVRT01) CFGTYPE(*DEV) STATUS(*ON)  
VRYCFG CFGOBJ(TAPVRT02) CFGTYPE(*DEV) STATUS(*ON)
```

3. Create tape image catalog or catalogs.

To create the image catalog, enter the following command:

```
CRTIMGCLG IMGCLG(CATALOG01) DIR('/MyCatalogDirectory01') TYPE(*TAP)
```

To create an additional catalog for later use for parallel backup, enter the following command:

```
CRTIMGCLG IMGCLG(CATALOG02) DIR('/MyCatalogDirectory02') TYPE(*TAP)
```

4. Create virtual tape volumes.

In this chapter, \*VRT256K density is used. This uses an optimum blocksize compatible with 35xx devices and the newer type QIC devices. If you have an older type physical device, use another density.

Refer to Chapter 3, “Implementing virtual tape storage” on page 33, for more information about densities and compatibility with physical tape devices.

- a. Create a virtual tape volume with the following command:

```
ADDIMGCLGE IMGCLG(CATALOG01) FROMFILE(*NEW) TOFILE(VRT001)
VOLNAM(VRT001) DENSITY(*VRT256K)
```

One virtual tape volume is created. For additional volumes, create them one at a time. If you have multiple volumes to add, use the sample CL program as described in Appendix B, “Sample command language” on page 461.

- b. Create virtual tape volumes in the second image catalog by entering the following command:

```
ADDIMGCLGE IMGCLG(CATALOG01) FROMFILE(*NEW) TOFILE(PAR001)
VOLNAM(PAR001) DENSITY(*VRT256K)
```

**Note:** BRMS requires unique volumes even though it is allowed to use the same volume names in different catalogs. Therefore, a different volume name is used in the second catalog.

The volumes in BRMS should be unique in the entire BRMS network.

You can now create additional volumes for the second catalog.

## 6.3 Installing BRMS

In this case we assume that you have set up BRMS, as described in “Installing BRMS” on page 28.

When BRMS is installed and PTFs applied, run the following command before using BRMS:

```
INZBRM OPTION(*RUNPRDINZ)
```

If you try to use BRMS after installation without running this command, you will receive the following message, as shown in Figure 6-1 on page 282 on the i5/OS Main Menu:

```
BRMS product initialization required.
```

```
MAIN                                i5/OS Main Menu                                System:  RCHAS08
Select one of the following:
    1. User tasks
    2. Office tasks
    3. General system tasks
    4. Files, libraries, and folders
    5. Programming
    6. Communications
    7. Define or change the system
    8. Problem handling
    9. Display a menu
   10. Information Assistant options
   11. iSeries Access tasks

   90. Sign off

Selection or command
===> WRKDEVBRM

F3=Exit  F4=Prompt  F9=Retrieve  F12=Cancel  F13=Information Assistant
F23=Set initial menu
BRMS product initialization required.
```

*Figure 6-1 INZBRM \*RUNPRDINZ required after installation of BRMS*

Figure 6-2 on page 283 shows the Additional Message Information screen, which explains why this message was sent.

```
Additional Message Information

Message ID . . . . . : BRM40A2      Severity . . . . . : 40
Message type . . . . . : Information
Date sent . . . . . : 12/04/05     Time sent . . . . . : 12:10:48

Message . . . . . : BRMS product initialization required.
Cause . . . . . : The Backup, Recovery and Media Services (BRMS) program
                  product has not been successfully initialized. BRMS operations cannot be
                  performed until this initialization process has completed successfully.
Recovery . . . . . : Run the following command to complete BRMS product
                  initialization.
                  INZBRM OPTION(*RUNPRDINZ)
                  BRMS product initialization can be a long running process. Use the following command to
                  retrieve an estimate of the time needed to complete the
                  initialization process.
                  INZBRM OPTION(*ESTPRDINZ)
                  The estimated time will be returned in message BRM402B.

Bottom
```

Figure 6-2 Show BRMS message BRM40A2

## INZBRM

Before you use the virtual devices, image catalog, and virtual volumes that have been set up in BRMS, enter the following command:

```
INZBRM OPTION(*DEVICE)
```

This brings up the devices in BRMS. Four virtual media classes are also created by BRMS with this command. This will be the case each time you run this command. Therefore, if you create additional virtual tape devices, you should run this command.

## 6.4 Setting up locations in BRMS for virtual tape

After virtual tape is set up and BRMS is installed, then set up BRMS for virtual tape, as explained here.

A *location* in BRMS represents the place where the volumes and the tape devices or libraries reside. And the first thing to consider is whether you want to use the default locations within BRMS, rather than create your own locations. The default locations that BRMS creates are VAULT and \*HOME.

In the case of physical devices and locations, these defaults may be acceptable to use. This chapter discusses the use of VAULT to store physical volumes.

For virtual tape, however, certain considerations should be kept in mind when determining whether to create your own locations or use the defaults.

### 6.4.1 Location considerations in BRMS

Consider the following points when planning BRMS locations:

- ▶ Because you are using virtual volumes, it may be better to create a location to reflect the virtual location for new volumes. You can use \*HOME, but it may be confusing when there are also physical volumes on this location.
- ▶ After backup, the data that is backed up is still on the system, since the virtual volumes are actually images on the disks. The way you should proceed now depends on your backup strategy:
  - After backup, copy the virtual volumes to physical tape volumes using DUPMEDBRM and remove the images after they are duplicated.
  - After backup, copy the virtual volumes to physical tape volumes using DUPMEDBRM and keep the images on the system for later use. This option may be an alternative for keeping the volumes in the physical media library for restore purposes.
  - After backup, the images have to be transferred or copied to other systems for restore or safety purposes.

In this chapter, we use location VIRTUAL for the virtual volumes. This will also be the home location for virtual volumes. When the virtual volumes are used for backup and are not duplicated, they will still be on location VIRTUAL. For volumes that are used for backup and duplicated to physical media, use location COPIED.

## Adding locations

To add locations in BRMS, do the following:

1. In the command line, enter the following command:

```
WRKLOCBRM
```

2. In the first line below Opt, type 1. Below Location, type VIRTUAL. The screen will now appear as shown in Figure 6-3.

```
Work with Storage Locations                                RCHAS08

Position to . . . . . Starting characters

Type options, press Enter.
 1=Add  2=Change  3=Copy  4=Remove  5=Display  6=Work with media
 7=Work with containers

Opt  Location      Volumes  Containers  Text
 1   VIRTUAL
     *HOME          11         0  Entry created by BRM configuration
     VAULT          5         0  Entry created by BRM configuration
```

Figure 6-3 Specify 1 to add location VIRTUAL in WRKLOCBRM

Press Enter and type your text on the Add storage Location screen. Notice that we kept the default Allow volumes to expire as \*N0, as shown in Figure 6-4 on page 286.

```

                                Add Storage Location

Type choices, press Enter.

Storage location . . . . . VIRTUAL      Name
Address line 1 . . . . . Image catalog on DASD
Address line 2 . . . . .
Address line 3 . . . . .
Address line 4 . . . . .
Address line 5 . . . . .
Contact name . . . . .
Contact telephone number. . . . .
Retrieval time . . . . . .0      Hours
Allow volumes to expire . . . . . *NO      *YES, *NO
Media slotting . . . . . *NO      *YES, *NO
Text . . . . . Location for virtual volumes

```

Figure 6-4 Add storage location VIRTUAL

3. Press Enter to add the location and to go back to the WRKLOCBRM screen.
4. To add another location, type 1 again on the first line below Opt. Type COPIED below Location. The screen will now appear as shown in Figure 6-5.

```

                                Work with Storage Locations                                RCHAS08

Position to . . . . . Starting characters

Type options, press Enter.
 1=Add  2=Change  3=Copy  4=Remove  5=Display  6=Work with media
 7=Work with containers

Opt  Location    Volumes  Containers  Text
 1   COPIED
     *HOME        11        0    Entry created by BRM configuration
     VAULT        5         0    Entry created by BRM configuration
     VIRTUAL      0         0

```

Figure 6-5 Specify 1 to add location COPIED in WRKLOCBRM

Press Enter and type your text in the Add storage Location screen as shown in Figure 6-6. Notice that Allow volumes to expire is changed to \*YES.

```

                                Add Storage Location

Type choices, press Enter.

Storage location . . . . . COPIED   Name
Address line 1 . . . . . Virtual volumes on DASD
Address line 2 . . . . .
Address line 3 . . . . .
Address line 4 . . . . .
Address line 5 . . . . .
Contact name . . . . .
Contact telephone number. . . . .
Retrieval time . . . . . .0      Hours
Allow volumes to expire . . . . . *YES      *YES, *NO
Media slotting . . . . . *NO        *YES, *NO
Text . . . . . Virtual volumes that have been duplicated

```

Figure 6-6 Add storage location VIRTUAL

The process of adding locations is now complete.

**Note:** Ensure that virtual volumes containing data and eligible for backup are actually duplicated to physical media.

If they are not duplicated before they expire, the data will be lost when they are reused.

## 6.4.2 Setting up virtual devices in BRMS

Devices in BRMS do not have to be set up manually, because INZBRM \*DEVICE creates the BRMS devices based on the devices in the native i5/OS. However, the devices are created with defaults. Since virtual devices are being discussed, you should change the parameters to suit your requirements.

To change the BRMS devices you want to use, do the following:

1. Type the following in the command line:

```
WRKDEVBRM
```

Then press Enter.

2. Type 2 in front of the device you want to change, as shown in Figure 6-7 on page 288, and press Enter.

```

                                Work with Devices                                RCHAS08

Position to . . . . .           Starting characters

Type options, press Enter.
1=Add 2=Change 4=Remove 5=Display
8=Work with status

Opt  Device      Category  Type/Model  Text
-----
      LANTAP      *TAP      6380/001   Entry created by BRM configuration
      MERVRT      *VRTTAP   63B0/001   Entry created by BRM configuration
      NEWVRT01     *VRTTAP   63B0/001   Entry created by BRM configuration
      NEWVRT05     *VRTTAP   63B0/001   Entry created by BRM configuration
      TAPVRTBB     *VRTTAP   63B0/001   Entry created by BRM configuration
      TAPVRTBB1    *VRTTAP   63B0/001   Entry created by BRM configuration
      TAPVRTBB2    *VRTTAP   63B0/001   Entry created by BRM configuration
2    TAPVRT01      *VRTTAP   63B0/001   Entry created by BRM configuration
      TAPVRT02      *VRTTAP   63B0/001   Entry created by BRM configuration
      TAPVRT06      *VRTTAP   63B0/001   Entry created by BRM configuration

```

Figure 6-7 Work with devices in BRMS

3. Change the parameter Location, shown in Figure 6-8, from \*HOME to VIRTUAL. After a volume is processed in this virtual tape device, it will be in location VIRTUAL.

```

                                Change Virtual Tape Device

Virtual device . . . . . : TAPVRT01
Device type/model . . . . . : 63B0/001

Type changes, press Enter.

Text . . . . . Virtual tape drive TAPVRT01

Location . . . . . VIRTUAL      Name, F4 for list

Use optimum block size . . . . . *YES      *NO, *YES
Next volume message . . . . . *NO      *YES, *NO
Tape mount delay . . . . . *IMMED     *IMMED, 1-999
Auto enroll media . . . . . *NO      *SYSPCY, *NO, *YES

Shared device . . . . . *NO      *YES, *NO
  Shared device wait . . . . . 30      Seconds

```

Figure 6-8 Change virtual tape device TAPVRT01

**Note:** Physical tape devices in BRMS are created by default with the Next volume message parameter \*YES. However, in the case of virtual tape devices, the Next volume message parameter is set to \*N0 by default.

In the case of standalone physical devices, this parameter should be set to \*YES to give the operator the time to mount the next volume.

4. Change the parameter Location of the second virtual tape drive TAPVRT02, as well.

The setting up of BRMS devices is now complete.

### 6.4.3 Creating virtual media classes

To distinguish between densities or volumes, select or create a media class. For virtual volumes, there are four different densities as described in Chapter 3, “Implementing virtual tape storage” on page 33.

To work with media classes, use the following command:

```
WRKCLSBRM
```

This displays a screen similar to the one shown in Figure 6-9 on page 290.

```

Work with Media Classes                                RCHAS08

Position to . . . . .                               Starting characters

Type options, press Enter.
  1=Add  2=Change  3=Copy  4=Remove  5=Display  6=Work with media

Opt  Class      Density  Capacity  Text
-----
QIC1000  *QIC1000  *DENSITY  Entry created by BRM configuration
QIC120   *QIC120   *DENSITY  Entry created by BRM configuration
QIC150   *QIC150   *DENSITY  Entry created by BRM configuration
QIC2DC   *QIC2DC   *DENSITY  Entry created by BRM configuration
QIC2GB   *QIC2GB   *DENSITY  Entry created by BRM configuration
QIC4DC   *QIC4DC   *DENSITY  Entry created by BRM configuration
QIC4GB   *QIC4GB   *DENSITY  Entry created by BRM configuration
QIC525   *QIC525   *DENSITY  Entry created by BRM configuration
SAVSYS   *QIC4DC   *DENSITY  Entry created by BRM configuration
VRT240K  *VRT240K  *DENSITY  Entry created by BRM configuration
VRT256K  *VRT256K  *DENSITY  Entry created by BRM configuration
More...

```

Figure 6-9 Work with media classes

Press PgDn for the other media classes, as shown in Figure 6-10 on page 291.

```

Work with Media Classes                                RCHAS08

Position to . . . . .                               Starting characters

Type options, press Enter.
 1=Add  2=Change  3=Copy  4=Remove  5=Display  6=Work with media

Opt  Class      Density  Capacity  Text
-----
VRT32K  *VRT32K  5 GB    32K density suites all real tape dri
VRT64K  *VRT64K  *DENSITY  Entry created by BRM configuration

Bottom

```

Figure 6-10 Second page of work with media classes

You can create your own media class, for example, to create separate media classes with the same density. In this chapter, however, we used the VRT256K volume containing the properties shown in Figure 6-11.

```

Display Media Class

Media class . . . . . : VRT256K
Density . . . . . : *VRT256K
Media capacity . . . . . : *DENSITY
Mark for label print . . . . . : *NONE
Label size . . . . . : 6 LPI
Label output queue . . . . . : *SYSPCY
Library . . . . . :
Shared media . . . . . : *NO
Write once media . . . . . : *NO
Text . . . . . : Entry created by BRM configuration

```

Figure 6-11 Display media class

To create a media class, follow these steps:

1. In the WRKCLSBRM screen, type 1. Below Class, specify the name you want to use for your own media class, as shown in Figure 6-12. Then press Enter.

Opt	Class	Density	Capacity	Text
1	MYCLASS			
	QIC1000	*QIC1000	*DENSITY	Entry created by BRM configuration
	QIC120	*QIC120	*DENSITY	Entry created by BRM configuration
	QIC150	*QIC150	*DENSITY	Entry created by BRM configuration
	QIC2DC	*QIC2DC	*DENSITY	Entry created by BRM configuration
	QIC2GB	*QIC2GB	*DENSITY	Entry created by BRM configuration
	QIC4DC	*QIC4DC	*DENSITY	Entry created by BRM configuration
	QIC4GB	*QIC4GB	*DENSITY	Entry created by BRM configuration
	QIC525	*QIC525	*DENSITY	Entry created by BRM configuration
	SAVSYS	*QIC4DC	*DENSITY	Entry created by BRM configuration
	VRT240K	*VRT240K	*DENSITY	Entry created by BRM configuration
	VRT256K	*VRT256K	*DENSITY	Entry created by BRM configuration

Figure 6-12 Create your own media class

2. In the following screen, specify a density (this example assumes that you want a media class of \*VRT240K). When you press Enter again, Figure 6-13 on page 293 is displayed.

```

Add Media Class

Type choices, press Enter.

Media class . . . . . MYCLASS      Name
Density . . . . . *VRT240K      F4 for list
Media capacity . . . . . *DENSITY    *DENSITY, Number nnnnn.nn
  Unit of measure . . . . .          1=KB, 2=MB, 3=GB
Mark for label print . . . . . *NONE    *NONE, *MOVE, *WRITE
Label size . . . . . 1          1=6 LPI, 2=8 LPI, 3=9 LPI
Label output queue . . . . . *SYSPCY    Name, *SYSPCY, *PRTF
  Library . . . . .          Name, *LIBL
Shared media . . . . . *YES          *YES, *NO
Write once media . . . . . *NO        *YES, *NO
Text . . . . .

More...

F3=Exit   F4=Prompt   F12=Cancel
Entry specified is not valid.

```

Figure 6-13 Shared media \*YES seems to be an invalid option

The Help text shown in Figure 6-14 identifies the problem.

```

.....:
:           Shared Media - Help           :
:                                           :
:   This media class cannot be shared by multiple systems. :
:   This is the only valid value when the media class uses :
:   a virtual density (*VRT32K *VRT64K *VRT240K *VRT256K). :
:                                           :
:                                           Bottom :
: F2=Extended help   F10=Move to top   F11=Search Index   :
: F12=Cancel         F20=Enlarge       F24=More keys       :
:                                           :
:.....:

```

Figure 6-14 Help text at shared media parameter

**Note:** Virtual media cannot be shared with other systems in a BRMS network; however these virtual volumes will be visible on other systems.

BRMS does not distinguish between physical and virtual media classes at creation time. We recommend the Shared media parameter in the media class for virtual volumes is changed to \*NO.

## 6.4.4 Creating move policies

A move policy in BRMS can be used to move volumes to a specific location. Physical volumes should be moved physically to the location according to the move policy. Virtual volumes are still on the system, and to reflect the function of those volumes, location VIRTUAL and location COPIED were created in paragraph locations.

Set up a move policy in which the volume will be moved from VIRTUAL to COPIED after the volumes are duplicated and eligible for expiring.

To work with move policies in BRMS, type the following command:

```
WRKPCYBRM *MOV
```

1. To add a new location, type 1 in the Opt column. In the Policy column, type the name of the policy you want to add (in this case, it is TO\_COPIED). Press Enter. The screen looks as shown in Figure 6-15.

```
Work with Move Policies                                RCHAS08
Position to . . . . . Starting characters
Type options, press Enter.
  1=Create  2=Change  3=Copy  4=Delete  5=Display
Opt  Policy      Text
  1   TO_COPIED
      OFFSITE     Entry created by BRM configuration
```

Figure 6-15 Work with move policies

2. The Create Move Policy screen is shown. Specify the options and parameters as shown in Figure 6-16 on page 295.

```

                                Create Move Policy                                RCHAS08
Move policy . . . . . TO_COPIED
Home location . . . . . VIRTUAL      Name, *SYSPCY, *ORIGIN, F4 list
Use container . . . . . *NO          *YES, *NO
Verify moves . . . . . *NO          *YES, *NO
Calendar for working days . . . *ALLDAYS      Name, *ALLDAYS, F4 for list
Calendar for move days . . . . *ALLDAYS      Name, *ALLDAYS, F4 for list
Text . . . . .

Type choices, press Enter.

Seq   Location   Duration
 10   COPIED     *EXP

```

Figure 6-16 Create a move policy TO\_COPIED

3. The volumes using this move policy will be moved to location COPIED, and they will be there until they expire. Use the following command to move volumes:

```
MOVMEDBRM
```

After they expire, the volumes will be moved back to the home location, which in this case is VIRTUAL.

4. Verify moves have been changed to \*NO, which means that the volumes are automatically moved when the MOVMEDBRM command is issued. No manual intervention is needed in this case. To verify the volumes manually, use the following command:

```
VFYMOVBRM
```

The intention of this command is to make the user or operator aware of the fact that the volume is moved. For physical volumes, this can be used to ensure that the physical locations match the locations in the BRMS database.

This chapter does not deal with manual intervention since the virtual volumes should be duplicated. BRMS does not move the volumes according the move policy when they are not duplicated yet.

If the volumes are used for backup and not duplicated yet, and you try to move them using MOVMEDBRM, message BRM1364 will be sent to the joblog as shown in Figure 6-17.

```

Additional Message Information

Message ID . . . . . : BRM1364      Severity . . . . . : 30
Message type . . . . . : Information
Date sent . . . . . : 12/07/05     Time sent . . . . . : 11:06:55

Message . . . . . : Media volume PAR003 not moved to location COPIED.
Cause . . . . . : The media volume PAR003 was not moved to location COPIED
                  because the volume is marked for duplication.

```

Figure 6-17 BRM1364 additional message information

At this point, the move policy for the virtual volumes has been created. The next stage is to create the move policy for the physical volumes.

1. Enter the following command:  
WRKPCYBRM \*MOV
2. Type 1 in the Opt column. In the Policy column, type the name of the policy you want to add (in this case, it is T0\_OUTD00R). The screen looks as shown in Figure 6-18. Press Enter.

```

Work with Move Policies                                RCHAS08

Position to . . . . . Starting characters

Type options, press Enter.
  1=Create  2=Change  3=Copy  4=Delete  5=Display

Opt  Policy      Text
  1   T0_OUTDOOR
      OFFSITE     Entry created by BRM configuration
      T0_COPIED

```

Figure 6-18 Work with move policies adding the move policy for physical volumes

3. In the Create Move Policy screen, specify the options and parameters as shown in Figure 6-19 on page 297.

```

                                Create Move Policy                                RCHAS08
Move policy . . . . . TO_OUTDOOR
Home location . . . . . *HOME      Name, *SYSPCY, *ORIGIN, F4 list
Use container . . . . . *NO        *YES, *NO
Verify moves . . . . . *NO        *YES, *NO
Calendar for working days . . . *ALLDAYS  Name, *ALLDAYS, F4 for list
Calendar for move days . . . . *ALLDAYS  Name, *ALLDAYS, F4 for list
Text . . . . .

Type choices, press Enter.

Seq   Location   Duration
 10   VAULT     *EXP

```

Figure 6-19 Create a move policy TO\_OUTDOOR

So far we have described how to set up locations and a move policy to prevent the volumes from being expired when they are not duplicated. The additional location COPIED is necessary to expire the volumes, because location VIRTUAL does not allow expiring volumes. A move policy for the physical volumes was also created.

### 6.4.5 Creating media policies

At this point the location, devices, move policies, and media classes to use have been determined. Next, you create a media policy.

1. Enter the following command to go to media policies:

```
WRKPCYBRM *MED
```

- In the Opt column, type 1. In the Policy column, type VIRTUAL. The screen looks as shown in Figure 6-20. Press Enter.

```
Work with Media Policies                                RCHAS08

Position to . . . . .                               Starting characters

Type options, press Enter
1=Create  2=Change  3=Copy  4=Delete  5=Display

Opt Policy      Text
1 VIRTUAL
  ARCHIVAL     Entry created by BRM configuration
  FULL         Entry created by BRM configuration
  INCR         Entry created by BRM configuration
  SAVF         Entry created by BRM configuration
  SAVSYS       Entry created by BRM configuration
  SYSTEM       Entry created by BRM configuration
  Z051124000   Full 35 days
  Z051124001   Entry created by BRM configuration
  Z051124002   Entry created by BRM configuration
  Z051127000   *NONE
```

Figure 6-20 Work with media policies

- Change the options in the Create Media Policy screen shown in the next two figures (Figure 6-21 and Figure 6-22 on page 299). After changing the options on the first screen, press PgDn and you will see the second screen.

```

                                Create Media Policy

Type choices, press Enter.

Media policy . . . . . VIRTUAL      Name
Retention type . . . . . 2           1=Date, 2=Days,
                                       3=Versions, 4=Permanent
Retain media . . . . . 4           Date, Number
Move policy . . . . . TO_COPIED     Name, *NONE, *ADSM, F4
Media class . . . . . VRT256K       Name, *SYSPCY, *ADSM, F4
Storage location . . . . . *ANY      Name, *ANY, F4 for list
Save to save file . . . . . *NO      *YES, *NO
ASP for save files . . . . . *SYSTEM Name, *SYSTEM, 1-32
Save file retention type . . . . . 4 1=Date, 2=Days,
                                       3=Permanent, 4=None
Retain save files . . . . . *NONE    Date, Number, *NONE
ASP storage limit . . . . . *SYS     *SYS, 1-99
Secure media . . . . . *NO          *YES, *NO, *ADSM
Text . . . . . Virtual volumes to be copied

More...

F3=Exit  F4=Prompt  F5=Refresh  F12=Cancel

```

Figure 6-21 Create media policy, first screen

```

                                Create Media Policy

Type choices, press Enter.

Required volumes . . . . . *NONE     *NONE, 1-9999
Mark volumes for duplication . . . *YES     *NO, *YES
Mark history for duplication . . . *NO     *NO, *YES

```

Figure 6-22 Create media policy next screen

The choices available are explained here:

- Retention type: Against this, you can choose to retain the volumes based on the number of days, date, versions, or permanently.
  - Date: This means they are based on a specific date.
  - Days: This indicates the number of days.
  - Versions: This means the number of versions of the same set of data that should be kept. Use caution when using this value, since it can result in volumes that never expire in cases of \*ALLUSR, \*IBM, and so on. The reason for this is because the datasets can differ due to a deleted or added library.
  - Permanent: This means that the volume never expires.

- Retain media: This represents the number of days or versions, depending on what is selected, for which the volumes should be retained.

In this chapter, we do not use savefiles. BRMS savefiles have a similar function as the virtual tape. However, they cannot be moved to other systems and only BRMS knows the contents of the savefile.

These savefiles are stored on the system. To move the data from the system, use the SAVSAVFBRM command.

- Secure Media: In this chapter, we do not use Secure Media. It determines whether or not you want to apply volume security to volumes in this media class. Volumes that are secured can only be read by users with the \*ALLOBJ or \*SECADM special authorities.
- Required volumes: This can be used if you want to ensure that there are enough volumes before the save. If this is not the case, the backup will not start. This is useful for physical volumes.

However, for virtual volumes, there is no reason to do this. You can create multiple virtual volumes as long as you have disk space, that is, until you reach the 256 maximum limit of volumes per image catalog.

- Mark volumes for duplication: This indicates that the volume has a flag and all the volumes with the flag turned on are eligible for duplication. After they are duplicated, the flag will be turned off. The command to duplicate BRMS volumes is DUPMEDBRM.

This option can be very useful, especially for virtual volumes, since the volumes have to be duplicated to physical media, unless you want to transfer the virtual volume images to another system.

- Mark history for duplication: This is a new option in V5R4 and can be used if you are duplicating parts or sequence numbers of a volume. BRMS then keeps tracking, whether the sequences are duplicated or not. To check

whether saved data items have turned this flag on, type WRKMEDIBRM, press Enter and press F11 twice.

- Marked for Duplication: This shows whether the flag is turned on or not.

## 6.4.6 Creating the link list

This section defines the backup items in the control group. One of the items used is a linklist.

1. To define a linklist, enter the following command:

```
WRKLBRM
```

Then press Enter.

2. In the next screen, type 1 in the Opt column, IFSUSRDTA in the List Name column, \*BKU in the Use column, and \*LNK in the Type column. The screen looks as shown in Figure 6-23. Press Enter.

Work with Lists					RCHAS08
Position to . . . . .			Starting characters		
Type options, press Enter.					
1=Add 2=Change 3=Copy 4=Remove 5=Display 6=Print					
Opt	List Name	Use	Type	Text	
1	IFSUSRDTA	*BKU	*LNK		
	ITSODBSAVE	*BKU	*LNK	Saves all ITS0 data bases	
	QALLSPLF	*BKU	*SPL	All printed output	
	QIBMLINK	*BKU	*LNK	All IBM directories	
	QLNKOMT	*BKU	*LNK	Associated user omit list for *LINK.	

Figure 6-23 Work with lists

3. In the next page, type your text and press Enter again.
4. This takes you back to the screen Work with lists. Change the list that has just been created, to add the IFS entries you want to back up. Type 2 in the Opt column in front of list IFSUSRDTA, and press Enter.
5. In the next page, type a plus sign (+) in the Objects field and press Enter. Now specify the \*INCLUDE options and \*OMIT options, as shown in Figure 6-24 on page 302.

```

Specify More Values for Parameter OBJ

Type choices, press Enter.

Objects:
Name . . . . . > '/'*

Include or omit . . . . . *INCLUDE      *INCLUDE, *OMIT

Name . . . . . > ''/QSYS.LIB'' ~'

Include or omit . . . . . > *OMIT      *INCLUDE, *OMIT

Name . . . . . > 'QDLS'

Include or omit . . . . . > *OMIT      *INCLUDE, *OMIT

Name . . . . . > 'QFileSvr.400'

Include or omit . . . . . > *OMIT      *INCLUDE, *OMIT

More...

```

Figure 6-24 First screen of change values in linklist

Scroll down the page to the next screen, which is shown in Figure 6-25 on page 303.

```

Specify More Values for Parameter OBJ

Type choices, press Enter.

Name . . . . . '/QOpensys'
Include or omit . . . . . *OMIT      *INCLUDE, *OMIT

Name . . . . . '/QNTC'
Include or omit . . . . . *OMIT      *INCLUDE, *OMIT

Name . . . . . '/QOPT'
Include or omit . . . . . *OMIT      *INCLUDE, *OMIT

Name . . . . .
Include or omit . . . . . *INCLUDE    *INCLUDE, *OMIT

More...

```

Figure 6-25 More values for parameter OBJ on change list on WRKLB RM

Press Enter twice, and the list will be changed.

This describes is an example of creating a linklist containing user data. You have the option of omitting directories.

**Note:** The virtual volumes also reside in an IFS directory, and you can omit the directory in the linklist. You can also change the ALWSAV attribute of the directory, which will prevent this directory from being saved. For more information about this topic, refer to 2.2.2, “The amount of space needed” on page 11.

## 6.4.7 Creating control groups for daily backup of user data

A control group is used to specify the items to be saved, the tape device to be used, the media policy to be used, and so on.

This section describes how to create control groups, with backup items for daily save operations, containing user data in IFS and libraries.

1. Type the following command to go to the control groups:

```
WRKCTLGBRM
```

This displays the screen shown in Figure 6-26.

Work with Backup Control Groups		RCHAS08	
Position to . . . . .	Starting characters		
Type options, press Enter			
1=Create	2=Edit entries	3=Copy	4>Delete 5=Display
6=Add to schedule	8=Change attributes	9=Subsystems to process ...	
	Full	Incr	Weekly
Control	Media	Media	Activity
Opt Group	Policy	Policy	SMTWTFS Text
*BKUGRP	Z051124000	FULL	*BKUPCY Backs up all user data
*SYSGRP	Z051124001	SAVSYS	*BKUPCY Backs up all system data
*SYSTEM	Z051124002	SYSTEM	*BKUPCY Backs up the entire system
ITSODBSAVE	Z051127000	Z051127001	Saves all ITS0 data bases

Figure 6-26 Work with backup control groups

You can now add your own control group for daily backup of user data.

2. Type 1 in the Opt column. Type DAILY in the Control Group column, and press Enter.
3. In the next screen (see Figure 6-27 on page 305), create your control group entries, press Enter, and then press F3 to exit the control group.

In the Exit control group screen, type: 1, which indicates save and exit session.

```

                                Create Backup Control Group Entries                                RCHAS08
Group . . . . . : DAILY
Default activity . . . . . FFFFFFFF
Text . . . . . Control group for daily backups

Type information, press Enter.

      Backup      Auxiliary  Weekly  Retain  Save  SWA
Seq  Items       List Storage  Activity Object While Message
      Type Pool Device SMTWTFS Detail Active Queue

10 *EXIT                *DFTACT
20 *SAVSECDTA          *DFTACT *NO
30 *SAVCFG             *DFTACT *NO
40 *ALLUSR             *SYSBAS *DFTACT *YES *NO
50 *ALLDLO             *DFTACT *YES *NO
60 IFSUSRDTA *LNK *ALLAVL *DFTACT *YES *NO
70 *EXIT                *DFTACT

```

Figure 6-27 Create backup control group entries

4. To change the attributes of the control group, go to the screen Work with control groups, type 8 in the Opt column in front of the control group DAILY, and press Enter.
5. In the next screen, change the options as shown in Figure 6-28 on page 306.

```

Change Backup Control Group Attributes

Group . . . . . : DAILY

Type information, press Enter.

Media policy for:
  Full backups . . . . . VIRTUAL      Name, F4 for list
  Incremental backups . . . . . VIRTUAL  Name, F4 for list
  Backup devices . . . . . TAPVRT01     Name, F4 for list

Parallel device resources:
  Minimum resources . . . . . 1         1-32, *NONE, *AVAIL
  Maximum resources . . . . . 1         1-32, *AVAIL, *MIN
  Sign off interactive users . . . . . *NO      *YES, *NO, *BKUPCY
  Sign off limit . . . . . *BKUPCY        0-999 minutes, *BKUPCY
  Default weekly activity . . . . . FFFFFFFF   SMTWTFS(F/I), *BKUPCY
  Incremental type . . . . . *BKUPCY        *CUMUL, *INCR, *BKUPCY
  Force full backup days . . . . . *BKUPCY    0-365, *NOMAX, *BKUPCY
                                          More...

F3=Exit  F4=Prompt  F12=Cancel

```

Figure 6-28 First page of change backup control group attributes

For most parameters, refer to the backup policy. However, this section specifies the actual values that should appear in the fields.

- Media policy: Use VIRTUAL as the media policy, as discussed in 6.4.5, “Creating media policies” on page 297.
- Backup device: Use TAPVRT01 as the backup device. It is connected to image catalog01 in this scenario, with volumes VRT001, VRT002, and so on.
- Parallel device resources: Use this parameter for parallel operations, to specify how many devices should be used.
- Sign off interactive users: Set this to \*NO, since it is assumed in this chapter that there is minimal system activity. However, if you want your users to be signed off, set this to \*YES.
- Default weekly activity: This is FFFFFFFF in this case, since the plan is to perform a full backup of the backup, regardless of the day the backup runs on.
- Incremental type: Select a cumulative backup or an incremental backup. This scenario, however, does not use incremental backup.

- Force full backup days: This is a new parameter in V5R4, which can be used to force a full backup to ensure that a full backup is done after a specified number of days. Since this option is not used in this scenario, this parameter was left at \*BKUPCY.

Scroll down the page to go to the second page of the Change Backup Control Group Attributes screen as, shown in Figure 6-29.

```

Change Backup Control Group Attributes

Group . . . . . : DAILY

Type information, press Enter.

Automatically backup
  media information . . . . . *NONE      *LIB, *OBJ, *NONE, *BKUPCY
Save access paths . . . . . *BKUPCY    *YES, *NO, *BKUPCY ...
Save contents of save files . . . . . *BKUPCY    *YES, *NO, *BKUPCY
Save spooled file data . . . . . *BKUPCY    *NONE, *ALL, *BKUPCY
Data compression . . . . . *BKUPCY    *DEV, *YES, *NO, *BKUPCY
Data compaction . . . . . *BKUPCY    *DEV, *NO, *BKUPCY
Target release . . . . . *BKUPCY    *CURRENT, *PRV, *BKUPCY
Clear . . . . . *BKUPCY    *NONE, *ALL...
Object pre-check . . . . . *BKUPCY    *YES, *NO, *BKUPCY
Append to media . . . . . *NO        *YES, *NO, *BKUPCY
End of tape option . . . . . *BKUPCY    *UNLOAD, *REWIND...
Journalled objects . . . . . *BKUPCY    *YES, *NO, *BKUPCY
Use optimum block size . . . . . *BKUPCY    *BKUPCY, *DEV, *YES, *NO

More...

F3=Exit  F12=Cancel

```

Figure 6-29 Second screen of change backup control group attributes

The parameters to be set here are as follows:

- Automatically backup media information: Use this to specify whether media information should be saved at the end of this control group. \*OBJ is for the most detailed level and \*NONE means no media information should be saved, which implies that QUSRBRM is *not* saved in the BRMS control group, post-processing.

In this scenario, you are saving on virtual media first, and then the media is duplicated to physical media. Therefore, do not save the media now, since it will reflect the virtual volumes on which the data is contained after the backup.

What is required is the media information with the physical volumes in it. Therefore, media information should be saved later at duplication time. Media information is required for recovery. If you do not have it, you will not be able to recover the backups from the BRMS database.

Another good reason to set this value to \*NONE is if you plan to run two or more control groups at the same time, which may lead to lock conflicts. If you have both control groups set to \*NONE for saving the media information, use the SAVMEDIBRM command separately after the saves are completed.

**Note:** Since most of the options in this screen are common backup parameters, you can refer to the backup policy since they apply for all backups.

- Append to media: Use this to add data to existing volumes that are active. This can be a useful parameter for physical volumes, especially if you want to use your volumes more efficiently. You can use it for virtual volumes too. However, if you have specified \*MIN for the image catalog size, there is no need to use \*APPEND, since the allocated space is minimum.

Now scroll down the page to the third screen of Change Backup Control Group Attributes, which is shown in Figure 6-30 on page 309.

```

Change Backup Control Group Attributes

Group . . . . . : DAILY

Type information, press Enter.

IPL after backup . . . . . *NO          *YES, *NO, *BKUPCY
  How to end . . . . . *BKUPCY        *CNTRLD, *IMMED, *BKUPCY
  Delay time, if *CNTRLD . . . . . *BKUPCY    Seconds, *NOLIMIT
  Restart after power down . . . . . *BKUPCY    *YES, *NO, *BKUPCY
  IPL source . . . . . *BKUPCY        *PANEL, A, B, *BKUPCY
  IPL restart type . . . . . *BKUPCY    *FULL, *IPLA, *SYS ...

Save active wait time:
  Object locks . . . . . 120          0-99999, *NOMAX
  Pending record changes . . . . . 120    0-99999, *NOCMTBDY, *NOMAX
  Other pending changes . . . . . 120    0-99999, *NOMAX
  Backup item exit program . . . . . *BKUPCY  Name, *NONE, *BKUPCY
  Exit program library . . . . .          Name
  Exit program format . . . . .          BKUI0100
  Missed object policy . . . . . *BKUPCY    Name, *NONE, *BKUPCY
  Clear missed objects . . . . . *NO      *NO, *YES

More...

```

Figure 6-30 Third screen of change backup control group attributes

The parameters to be set here are as follows:

- IPL after backup: In this scenario, set it to \*NO, since in this scenario, you have to IPL the system after backup.
- Save active wait time: This points to the Save While Active option in the Backup item list in the control group. Since you do not have to use Save While Active in this scenario, this value does not apply.
- Backup item exit program: This is a new parameter in V5R4. With this option, you can control each backup item entry in the backup control group. The layout and options of the Exit program are provided in Appendix C, “Quick start guide” on page 471.
- Missed object policy: This, too, is a new parameter in V5R4, and it can be set to \*YES in order to track the missed objects. These objects will then be added to the control group or the list specified in this parameter. When this control group runs, the missed objects will be saved.

Scroll down the page to go to the final screen of Change Backup Control Group Attributes, which is shown in Figure 6-31 on page 310.

```

Additional Backup Policy Properties

Client backup policy . . . . . : DAILY

Type information, press Enter.

Allow activity overrides . . . . . *YES      *NO, *YES
Allow retention overrides . . . . . *YES      *NO, *YES
Additional management:
  TCP/IP servers . . . . . *NO          *NO, *END, *RESTART, *BOTH
  Lotus servers . . . . . *NO          *NO, *END, *RESTART, *BOTH
  Integrated screens servers . . . . . *NO      *NO, *VARYOFF, *VARYON ...
  Guest partitions . . . . . *NO        *NO, *VARYOFF, *VARYON ...
  Unmount user-defined file systems . . . *NO      *NO, *YES
  Run maintenance after backup . . . . . *NO      *NO, *YES

```

Figure 6-31 Final screen of change backup control group attributes

These settings cannot be changed from a 5250 screen. You can change these options only with IBM @server iSeries Navigator. These options are discussed in 7.9, “Parameters available only from Navigator” on page 422.

Press Enter to confirm all the options that have been set, and press F3 and type option 1 to exit and save the control group attributes.

## 6.4.8 Running the daily backup

Now that the setup for daily backup is complete, you can run the daily backup or schedule the daily nightly backup.

In this scenario, the backup is run interactively from the console. However, in order to understand how to schedule a job from the Work with Backup Control Groups screen, perform the following steps:

1. Enter the following command:

```
WRKCTLGBRM
```

Then press Enter.

2. Type option 6 in front of the DAILY backup control group and press Enter. The screen shown in Figure 6-32 on page 311 is displayed.

```

Add Job Schedule Entry (ADDJOBSCDE)

Type choices, press Enter.

Job name . . . . . > QBRMBKUP      Name, *JOBID
Command to run . . . . . > STRBKUBRM CTLGRP(DAILY) SBMJOB(*NO)

Frequency . . . . . > *WEEKLY      *ONCE, *WEEKLY, *MONTHLY
Schedule date . . . . . > *NONE     Date, *CURRENT, *MONTHSTR...
Schedule day . . . . . > *ALL       *NONE, *ALL, *MON, *TUE...
      + for more values
Schedule time . . . . . > '23:00'   Time, *CURRENT
Save . . . . . *YES                *NO, *YES

More...

```

Figure 6-32 Adding the backup job to the job scheduler

You can change the values here according to your own backup strategy. If you want to run the backup now without scheduling, use the following command:

```
STRBKUBRM CTLGRP(DAILY) SBMJOB(*YES)
```

To run the backup interactively, use the following command:

```
STRBKUBRM CTLGRP(DAILY) SBMJOB(*NO)
```

After the backup is completed, message BRM1049 is issued, indicating that the backup is completed successfully as shown in Figure 6-33.

```

Selection or command
====>

F3=Exit  F4=Prompt  F9=Retrieve  F10=Commands  F12=Cancel  F13=Functions
Control group DAILY type *BKU processing is complete.

```

Figure 6-33 Backup finished successfully

You can check the virtual volumes on the Work with Media screen shown in Figure 6-34 on page 312.

Work With Media								
						System: RCHAS08		
Position to . . . . .			Starting characters					
Type options, press Enter.								
1=Add 2=Change 4=Remove 5=Display 6=Work with serial set 7=Expire								
8=Move 10=Reinitialize ...								
Opt	Volume Serial	Expired	Creation Date	Expiration Date	Location	Move Date	Media Class	Dup Sts
	VRT001 +		12/06/05	12/10/05	VIRTUAL	12/05/05	VRT256K	1
	VRT002 +		12/06/05	12/10/05	VIRTUAL	12/05/05	VRT256K	1
	VRT003 +		12/06/05	12/10/05	VIRTUAL	12/05/05	VRT256K	1
	VRT004	*YES	12/05/05	12/06/05	VIRTUAL	12/05/05	VRT256K	
	VRT005	*YES	12/05/05	12/06/05	VIRTUAL	12/05/05	VRT256K	
	VRT006 +		12/06/05	12/10/05	VIRTUAL	12/05/05	VRT256K	1
	VRT007 +		12/06/05	12/10/05	VIRTUAL	12/06/05	VRT256K	1

Figure 6-34 Work with media showing the volumes with the DupSts mark

The 1 in the DupSts column indicates that the volumes are marked for duplication, but are not duplicated yet. The volumes display a plus sign (+) after the volume name, which indicates that the volumes are a member of a serial set, a parallel set, or both. This is shown in Figure 6-35 on page 313.

```

Work With Media
System: RCHAS08
Position to . . . . . Starting characters
Type options, press Enter.
 1=Add  2=Change  4=Remove  5=Display  6=Work with serial set  7=Expire
 8=Move 10=Reinitialize ...

  Volume
Opt  Serial  System      Move      Serial  Parallel
      Serial  System      Policy    Set      Set

VRT001 + APPN.RCHAS08 TO_COPIED *YES *NO
VRT002 + APPN.RCHAS08 TO_COPIED *YES *NO
VRT003 + APPN.RCHAS08 TO_COPIED *YES *NO
VRT004 APPN.RCHAS08 *NONE *NO *NO
VRT005 APPN.RCHAS08 *NONE *NO *NO
VRT006 + APPN.RCHAS08 TO_COPIED *YES *NO
VRT007 + APPN.RCHAS08 TO_COPIED *YES *NO

More...

```

Figure 6-35 Work with media showing the volumes that are part of the backup set

For this backup, BRMS used five virtual volumes.

### 6.4.9 Duplicating media

Virtual volumes are still on the disk and have to be duplicated to physical media. If you decide to transfer them to another system in order to restore the data on that system, you may decide against duplicating the volumes. However, transferring volumes to other systems is not possible using BRMS, since virtual volumes cannot be shared between systems in a BRMS network today.

1. To duplicate volumes with BRMS, use the following command:

```
DUPMEDBRM
```

Then press F4 and F10.

Figure 6-36 on page 314 will be displayed.

```

Duplicate Media using BRM (DUPMEDBRM)

Type choices, press Enter.

From volume identifier . . . . . Character value, *LIST...
Resume key . . . . . 1-999999, *ALL
File group . . . . . *ALL *ALL, *SYSTEM, *BKUGRP, *SY...
File group type . . . . . *ALL *ALL, *BKU, *ARC
From media class . . . . . *ALL *ALL, QIC1000, QIC120, QIC1...
From device . . . . . LANTAP, NEWVRT01, NEWVRT05...
To device . . . . . LANTAP, NEWVRT01, NEWVRT05...
From sequence number:
  Starting file sequence number *FIRST 1-16777215, *ALL, *FIRST
  Ending file sequence number . *LAST 1-16777215, *LAST, *ONLY
To sequence number . . . . . 1 1, *END
To media policy . . . . . *SYSPCY *SYSPCY, *NONE, ARCHIVAL, F...
Input volume list . . . . . *VOL Character value, *VOL, *SET
      + for more values
From device end option . . . . . *REWIND *REWIND, *LEAVE, *UNLOAD
To device end option . . . . . *UNLOAD *UNLOAD, *LEAVE, *REWIND
                                          More...

```

Figure 6-36 Duplicate media using BRMS

The following parameters can be set in this screen.

- From volume identifier - the following options can be specified:
  - \*LIST: This can be used to specify a list of volumes. The names of the volumes have to be specified in the Input volume list parameter.
  - \*RESUME: This is new in V5R4 and can be used in case a previous duplication failed. The Resume key, which can be found in the Display Media Information screen, must be specified in such a situation.
  - \*SCHHST: This is new in V5R4 and can be used to copy data from volumes that was not duplicated when the volume was duplicated. This value only works for volumes with the Mark history for duplication flag turned on, as described on page 300.
  - \*SEARCH: The most common and easiest option to use is \*SEARCH, since it duplicates all the volumes with the Mark for Duplication flag on. After they are copied, the flag is turned off.

However, if there are many volumes to copy and you have more than one physical drive to copy to, you can decide to run two or more DUPMEDBRM jobs at the same time. However, you cannot use \*SEARCH in that case, because this will result in jobs stealing volumes from the other.

- Volume identifier
  - From device: This is the virtual device in this scenario.
  - To device: This is the physical device to write the physical volumes. In this scenario, an Ultrium2 type media library called SR3582RMU1 is used.
  - To media policy: Specify the media policy you want to use for physical volumes (in this scenario, it is DAILY).
  - Input volume list: This has two possible options:
    - \*VOL: Use this when you want to copy a single volume as specified in the VOL parameter From volume identifier.
    - \*SET: Use this if you want to copy a set of volumes in a batch job. For interactive, using \*SET is not necessary for duplicating sets, since the prompt shows the volumes in the set.

Press PgDn to go to the next screen of DUPMEDBRM, as shown in Figure 6-37, and change the options accordingly.

```

Duplicate Media using BRM (DUPMEDBRM)

Type choices, press Enter.

                                Additional Parameters

To volume identifier . . . . . *MOUNTED      Character value, *MOUNTED
      + for more values
Retain object detail . . . . . *NO           *NO, *YES
Expiration date . . . . . *MEDPCY          Date, *MEDPCY, *PERM
Move policy . . . . . *MEDPCY             *MEDPCY, *NONE, OFFSITE, TO...
Media class . . . . . *MEDPCY            *MEDPCY, *SYSPCY, QIC1000, ...
Location . . . . . *MEDPCY              *MEDPCY, *ANY, *HOME, COPIE...
Secure volume . . . . . *MEDPCY          *MEDPCY, *NO, *YES
Required volumes . . . . . *MEDPCY        1-9999, *MEDPCY, *NONE
Mark volumes for duplication . . *MEDPCY   *MEDPCY, *NO, *YES
Mark history for duplication . . *MEDPCY   *MEDPCY, *NO, *YES
Save media information . . . . . *OBJ       *NONE, *BKUPCY, *LIB, *OBJ

                                                Bottom
  
```

Figure 6-37 Next screen of duplicate media using BRM

The following parameters can be set in this screen.

- Volume identifier: You can specify a specific output volume you want to use (in this case, it is \*MOUNTED).

- Retain object detail: This has no specific function, since the object detail information will be retained for the output volume if it is available for the input volume on which the backup was performed.
- Expiration date
- Move Policy
- Media class
- Location
- Secure volume
- Required volumes
- Mark volumes for duplication
- Mark history for duplication)

These eight parameters can be kept at \*MEDPCY, since there is no need to override them in this case.

- Save media information: This is new in V5R4 and is a recommended option for use in duplicating virtual volumes. The files in QUSRBRM are added to the volume when using this option, which are required when you want to recover the data on this volume using this BRMS media information.

Automatically, backup media information has already been detailed in the control group in Figure 6-30 on page 309. If you use the media information saved at the end of the control group, the files contain the wrong information, since that version contains the virtual volumes and at that time, BRMS does not know which volume will be the output volume.

**Note:** The default value of the Save media information option of the DUPMEDBRM command is set to \*NONE. However, the recommended value is \*OBJ or at least \*LIB when duplicating a volume with BRMS.

You can also use \*BKUPCY if you have specified it in your backup policy. With this option, the current version of QUSRBRM files is added to the volumes or volume set.

- ▶ If you want to duplicate the volumes in a batch, use the following command:

```
SBMJOB CMD(DUPMEDBRM VOL(VRT001) FROMDEV(TAPVRT01) TODEV(SR3582RMU1) MEDPC
Y(DAILY) FROMVOL(*SET)) LOG(4 00 *SECLVL) LOGCLPGM(*YES)
```

After the volumes are duplicated, type the following command:

WRKMEDBRM

This will display a screen similar to Figure 6-38 on page 317.

```
Work With Media
System: RCHAS08
Position to . . . . . Starting characters
Type options, press Enter.
 1=Add  2=Change  4=Remove  5=Display  6=Work with serial set  7=Expire
 8=Move 10=Reinitialize ...
```

Opt	Volume Serial	Expired	Creation Date	Expiration Date	Location	Move Date	Media Class	Dup Sts
	VRT001 +		12/06/05	12/10/05	COPIED	12/05/05	VRT256K	*
	VRT002 +		12/06/05	12/10/05	COPIED	12/05/05	VRT256K	*
	VRT003 +		12/06/05	12/10/05	COPIED	12/05/05	VRT256K	*
	VRT004	*YES	12/05/05	12/06/05	VIRTUAL	12/05/05	VRT256K	
	VRT005	*YES	12/05/05	12/06/05	VIRTUAL	12/05/05	VRT256K	
	VRT006 +		12/06/05	12/10/05	COPIED	12/05/05	VRT256K	*
	VRT007 +		12/06/05	12/10/05	COPIED	12/06/05	VRT256K	*

More...

Figure 6-38 Work with media after duplication

Notice the asterisk (\*) in the DupSts column in the row of the volumes in the set. Figure 6-34 on page 312 shows that the DupSts column contained a 1 before they were duplicated.

Now press F23. The screen shown in Figure 6-39 on page 318 is displayed.

```

Work With Media
System: RCHAS08
Position to . . . . . Starting characters
Type options, press Enter.
 11=Mark for label print  13=Display contents  14=Duplicate data
 15=Display duplicates ...

  Volume      Creation Expiration      Move      Media      Dup
Opt Serial    Expired   Date      Date      Location  Date      Class     Sts
-----
VRT001 +      12/06/05 12/10/05 COPIED    12/05/05 VRT256K   *
VRT002 +      12/06/05 12/10/05 COPIED    12/05/05 VRT256K   *
VRT003 +      12/06/05 12/10/05 COPIED    12/05/05 VRT256K   *
VRT004 *YES    12/05/05 12/06/05 VIRTUAL   12/05/05 VRT256K
VRT005 *YES    12/05/05 12/06/05 VIRTUAL   12/05/05 VRT256K
VRT006 +      12/06/05 12/10/05 COPIED    12/05/05 VRT256K   *
VRT007 +      12/06/05 12/10/05 COPIED    12/06/05 VRT256K   *
More...

```

Figure 6-39 Work with media showing the volumes and more options

Type 15 in front of one of the volumes in the set and press Enter. This shows the volumes in the set, together with the physical volume to which the virtual volumes are copied (output volume) as shown in Figure 6-40.

```

Display Duplication Cross Reference RCHAS08

  Volume  Volume  Expiration  --- Duplication ---  --- Last entry ---
Type Serial Seq    Date      Date      Time      Date      Time
*INP VRT006   1  12/10/05  12/06/05  13:30:51  12/06/05  9:27:27
*INP VRT007   2  12/10/05  12/06/05  13:30:51  12/06/05  9:27:27
*INP VRT001   3  12/10/05  12/06/05  13:30:51  12/06/05  9:27:27
*INP VRT002   4  12/10/05  12/06/05  13:30:51  12/06/05  9:27:27
*INP VRT003   5  12/10/05  12/06/05  13:30:51  12/06/05  9:27:27
*OUT 759AGK   1  12/16/05  12/06/05  13:30:51  12/06/05  9:34:16

```

Figure 6-40 Display duplicate volumes

Figure 6-41 on page 319 shows physical volume 759AGK with media class ULTRIUM2 used as output volume.

```

Work With Media
System: RCHAS08
Position to . . . . . Starting characters
Type options, press Enter.
 1=Add  2=Change  4=Remove  5=Display  6=Work with serial set  7=Expire
 8=Move 10=Reinitialize ...

Volume          Creation Expiration          Move      Media      Dup
Opt Serial      Expired  Date      Date      Location  Date      Class     Sts
759AGK          12/06/05 12/16/05 SR3582RMU1 *NONE     ULTRIUM2  *

```

Figure 6-41 Work with media showing the physical output volume

Figure 6-42 shows duplicate volumes again, but for volume 759AGK.

```

Display Duplication Cross Reference RCHAS08

Type  Volume  Volume  Expiration  --- Duplication ---  --- Last entry ---
      Serial  Seq     Date       Date       Time         Date       Time
*INP  VRT006   1      12/10/05   12/06/05   13:30:51   12/06/05   9:27:27
*INP  VRT007   2      12/10/05   12/06/05   13:30:51   12/06/05   9:27:27
*INP  VRT001   3      12/10/05   12/06/05   13:30:51   12/06/05   9:27:27
*INP  VRT002   4      12/10/05   12/06/05   13:30:51   12/06/05   9:27:27
*INP  VRT003   5      12/10/05   12/06/05   13:30:51   12/06/05   9:27:27
*OUT  759AGK   1      12/16/05   12/06/05   13:30:51   12/06/05   9:34:16

```

Figure 6-42 Display duplicate volumes again, but now for volume 759AGK

### 6.4.10 Running media movement

The data has been copied to physical media, but now the volumes should be moved to the appropriate location. There are two ways of doing this, as described here:

- ▶ One method is to run BRMS maintenance and specify that you want to run media movement.
- ▶ The other method is to move them using the MOVMEDBRM command separately.

The physical volume must be moved offsite using the move policy TO\_OUTDOOR, and the virtual volumes must be moved using the TO\_COPIED move policy created in 6.4.4, “Creating move policies” on page 294.

The volumes can be moved with just one command:

```
MOVMEDBRM
```

However, if you want to move them separately, run the following commands:

```
MOVMEDBRM MOVPCY(TO_OUTDOOR)
MOVMEDBRM MOVPCY(TO_COPIED)
```

The virtual volumes are now in the COPIED location and the physical volume in location OUTDOOR.

## 6.5 BRMS maintenance

BRMS maintenance should be performed on a daily basis. This section discusses the possible options when running BRMS maintenance.

**Note:** Before running BRMS maintenance, make sure there is no BRMS activity, since BRMS maintenance should be run when no other BRMS jobs are running.

Follow these steps:

1. Type the following command:

```
STRMNTBRM
```

Then press F4 to prompt for the options.

Figure 6-43 on page 321 will be displayed.

```

Start Maintenance for BRM (STRMNTBRM)

Type choices, press Enter.

Expire media . . . . . *YES          *YES, *NO
Expire media set volumes . . . . *NO          *NO, *YES
Remove media information:
  Media contents . . . . . *EXP          *EXP, *NONE, *REUSE
  Object level detail . . . . . *MEDCON    1-9999, *MEDCON
Remove migration information . . 180          1-9999, *NONE
Run media movement . . . . . *NO          *NO, *YES
Remove log entries:
  Type . . . . . *ALL          *ALL, *NONE, *ARC, *BKU, *M...
  From date . . . . . *BEGIN        Date, *BEGIN, *CURRENT, nnnnn
  To date . . . . . 90            Date, *END, *CURRENT, nnnnn
Run cleanup operations . . . . . *YES          *YES, *NO
Retrieve volume statistics . . . *YES          *YES, *NO
Audit system media . . . . . *NONE
      + for more values
Change BRM journal receivers . . *YES          *YES, *NO

```

More...

Figure 6-43 Start maintenance for BRM

The following parameters are displayed in this screen:

- Expire media: Use this for expiring the media. If you want to expire media separately rather than using the STRMNTBRM command, use the command STREXPBRM.
- Expire media set volumes applies to volumes: If one or more volumes in a set is eligible for expiration and there is active data on one volume, \*NO will keep the entire set active until all the data is expired. In case of \*YES, only the volume with the active data will be kept active.
- Remove media information: If you want to keep the media information in the BRMS database until the volume is reused, use \*REUSE. If you want to keep it anyway, use \*NONE. If the information can be removed when the volume expires, use \*EXP.
- Remove migration information: Use this for removing media information regarding migration. This option applies only to the BRMS-Advanced Functions feature.
- Run media movement: \*YES performs MOVMEDBRM for you with the default options. If you do not want this or if you want to run this command separately, use the command as described in 6.4.10, “Running media movement” on page 319.

- Remove log entries: Use this to clean up the BRMS history entries.  
Run clean up operations for general BRMS cleanup: This option includes various BRMS general routines such as creation of location analysis report, analysis of deleted libraries, and so on.
- Retrieve volume statistics: Use this to retrieve the volume statistics. If necessary, you can print a report with PRTMEDBRM TYPE(\*STATISTICS).
- Audit system media: Use this to specify media information as contained by one or more systems in the network group to be audited and differences in media information resolved. If you expect media information inconsistency, use this option. However, as of now, this option only generates a report. The default is \*NONE.
- Change journal receivers: This specifies whether to change the receivers for the BRMS journals when the STRMNTBRM command processes. When the BRMS journal receivers are changed, the old BRMS journal receiver is deleted.

Press PgDn to view the next screen of STRMNTBRM command, as shown in Figure 6-44.

```

                                Start Maintenance for BRM (STRMNTBRM)

Type choices, press Enter.

Print expired media report . . . *YES          *YES, *NO
Print version report . . . . . *EXPMED       *EXPMED, *NO, *YES
Print media information . . . . *YES          *YES, *NO
Print recovery reports . . . . . *ALL         *ALL, *NONE, *RCYACT...
      + for more values
Recovery locations . . . . . *ALL           Name, *ALL, *HOME
      + for more values
Print system information . . . . *NO          *NO, *YES
Reorganize BRMS database . . . . *NO          *NO, *YES
Auto-retrieved objects:
  Refree . . . . . *NO          *NO, *YES

```

Figure 6-44 Next screen of Start Maintenance for BRM

The print options on this screen can be used to print expired media reports, version reports, media information reports, recovery reports, recovery location reports, and system information. Following are the parameters:

Reorganize BRMS database: Use this to reorganize the physical files in QUSRBRM. When \*YES is specified, RGZPFM is performed against the files in QUSRBRM and the occupied space of the deleted records will be

freed. If you used this option a long time ago or used the RGZPFM command for the QUSRBRM files, it can take a long time, especially if you have retained all object details as specified in the backup control group.

- Auto-retrieved objects: This applies only to the BRMS-Advanced Functions feature.

Until now, we have been working interactively and the options of STRMNTBRM were discussed. Typically, however, it is more common and efficient to use a scheduling function and to run this command on a daily basis.

## **Create recovery report**

During maintenance, you can create recovery reports. One of the commands that is actually used to generate recovery reports is STRRCYBRM.

A recovery report shows which media is required to recover your system or recover items. A recovery report is also required, along with physical tapes, to perform recovery.

1. To view the options, type the following command:

```
STRRCYBRM
```

Then press F4 and F10.

Figure 6-45 on page 324 will be displayed.

```

Start Recovery using BRM (STRRCYBRM)

Type choices, press Enter.

Option . . . . . > *CTLGRP      *SYSTEM, *ALLDLO, *ALLUSR...
Action . . . . . > *REPORT      *REPORT, *RESTORE
Time period for recovery:
  Start time and date:
    Beginning time . . . . . *AVAIL      Time, *AVAIL
    Beginning date . . . . . *BEGIN      Date, *CURRENT, *BEGIN
  End time and date:
    Ending time . . . . . *AVAIL      Time, *AVAIL
    Ending date . . . . . *END        Date, *CURRENT, *END
Use save files . . . . . *YES        *YES, *NO
Use TSM . . . . . *YES            *YES, *NO
Control group selection:
  Control group . . . . . *SELECT      Name, *SELECT, *NONE...
  Sequence number . . . . .          1-99
      + for more values

More...

```

Figure 6-45 Start recovery using BRMS

The following parameters are shown:

- Option: In the Option parameter, press F4 to show the complete list of options. The option you specify here determines how to recover.
  - If you use \*SYSTEM, the recovery will be for the entire system.
  - If you specify \*ALLUSR, the recovery is based on just recovering \*ALLUSR libraries.
- In this scenario, the focus is on \*CTLGRP, which means that you want to recover one or more items as specified in control group DAILY. Depending on the option you choose, other options will show up (for example, an option to specify the control group, and so on).
- Action: With this option, you can decide whether you want to recover one or more items immediately from a list shown on the screen, or if you want to create just a report.
- The report option generates two spoolfiles, one for the complete list of recovery steps and one for the summary of volumes to be used.
- Time period for recovery: With this option, you can select a period which you want to recover. Using this option, it is possible to not restore your last saved items, but instead restore a saved item in an earlier period.

- Use save files: If the most recent data is in BRMS savefiles and not yet on physical volumes, use \*YES for this option.
  - Use TSM: Use this when you have saved your data to a TSM server.
2. Press PgDn to view the next screen of Start Recovery using BRM as shown in Figure 6-46.

```

Start Recovery using BRM (STRRCYBRM)

Type choices, press Enter.

Libraries to omit . . . . . *DELETE      Name, generic*, *DELETE...
      + for more values
Allow duplicate entries . . . . *NO        *NO, *YES

                        Additional Parameters

Volume location . . . . . *ALL          *ALL, $, *HOME, #, @, AA#$...
      + for more values
From system . . . . . *LCL
Print system information . . . . *NO        *NO, *YES
Use duplicate media . . . . . *NO        *NO, *YES
User recovery information . . . *NONE      *NONE, *ADD

```

Figure 6-46 Second screen of start recovery using BRM

Following are the parameters in this screen:

- Libraries to omit: Use this to omit libraries. The default value is \*DELETE.
- Allow duplicate entries: Use this if you have selected more than one control group to recover and there are multiple entries due to overlap in save items.
- Volume location: Use this to specify volumes from a specific location, for example, if you have both copies offsite on different locations and want to use the volumes of one of the locations.
- From system: Use this for using volumes from a specific system.
- Print system information: This prints system information that should be maintained for disaster recovery and system verification purposes.
- Use duplicate media: Specify \*YES if you want to show the duplicate volumes in the list, instead of the original volumes. The default value is \*NO, which means that the original volumes are shown. However, in the case of virtual volumes that are successfully duplicated, the list shows the physical volumes with \*NO. Virtual volumes are supposed to be expired once they are duplicated, unless you want to keep a copy on your system.

– User recovery information: Use this to add specific user information. Read the help text for more information.

3. To create a recovery report, use this command:

```
STRRCYBRM OPTION(*CTLGRP) ACTION(*REPORT) CTLGRP((DAILY))
```

This will generate two reports, one describing a complete list of steps required to recover the data you requested (spooled file name QP1ARCY) and the other showing the list of volumes required for recovery (spooled file name QP1A2RCY). The list of volumes is shown in Figure 6-47.

```
File . . . . . : QP1A2RCY
Control . . . . .
Find . . . . .
*...+...1...+...2...+...3...+...4...+...5...+...6...+...7...+...8...+...
5722BR1 V5R4M0 060210          Recovery Volume Summary Report          RCHAS08
Volume      Media      Creation  Expiration  Location  Storage  Volume
Serial  Expired  Class    Date        Date        Date      Location  Slot
VRT001          VRT256K  12/06/05  12/10/05   12/05/05   VIRTUAL  83
Duplicate volume(s) . . . . . : 759AGK
VRT002          VRT256K  12/06/05  12/10/05   12/05/05   VIRTUAL  1
VRT003          VRT256K  12/06/05  12/10/05   12/05/05   VIRTUAL  85
VRT006          VRT256K  12/06/05  12/10/05   12/05/05   VIRTUAL  89
VRT007          VRT256K  12/06/05  12/10/05   12/06/05   VIRTUAL  2
759AGK          ULTRIUM2 12/06/05  12/16/05   *NONE      SR3582RMU1
Duplicate volume(s) . . . . . : VRT001
Total volumes needed for recovery . . . . . : 8
* * * * * E N D   O F   L I S T I N G   * * * * *
```

Figure 6-47 Volumes needed for recovery

4. If you want to recover the control group, rather than create a recovery report, use the following command:

```
STRRCYBRM OPTION(*CTLGRP) ACTION(*RESTORE) CTLGRP((DAILY))
```

Figure 6-48 on page 327 shows a part of the list that will be displayed.

Select Recovery Items				RCHAS08				
				Select action	. . . . . : *ALL			
				Select volume	. . . . . :			
Type options, press Enter.								
1=Select 4=Remove 5=Display 7=Specify object								
Opt	Item	Save Date	Save Time	Save Type	Parallel Devices	Volume Serial	File Sequence	Expire Date
	QDSNX	12/06/05	9:27:27	*FULL		759AGK	59	12/16/05
	QGPL	12/06/05	9:27:27	*FULL		759AGK	79	12/16/05
	QMGTC	12/06/05	9:27:27	*FULL		759AGK	60	12/16/05
	QMGTC2	12/06/05	9:27:27	*FULL		759AGK	61	12/16/05
	QPFRDATA	12/06/05	9:27:27	*FULL		759AGK	62	12/16/05
	QRCL	12/06/05	9:27:27	*FULL		759AGK	63	12/16/05
	QSRVAGT	12/06/05	9:27:27	*FULL		759AGK	64	12/16/05
	QS36F	12/06/05	9:27:27	*FULL		759AGK	65	12/16/05
	QUSRDIRDB	12/06/05	9:27:27	*FULL		759AGK	66	12/16/05
	QUSRIJS	12/06/05	9:27:27	*FULL		759AGK	67	12/16/05
	QUSRNOTES	12/06/05	9:27:27	*FULL		759AGK	68	12/16/05
								More...

Figure 6-48 Select recovery Items

Notice that the physical volumes are shown. This is because you used the default value USEDUPMED(\*NO).

If the USEDUPMED(\*YES) option had been used, the screen will appear as shown in Figure 6-49 on page 328.

```

Select Recovery Items                                RCHAS08

Select action . . . . . : *ALL
Select volume . . . . . :

Type options, press Enter.
1=Select  4=Remove  5=Display  7=Specify object

  Saved      Save      Save      Save      Parallel Volume      File      Expire
pt Item      Date      Time      Type      Devices  Serial      Sequence  Date
QDSNX      12/06/05  9:27:27  *FULL                    VRT001      21      12/10/05
QGGL      12/06/05  9:27:27  *FULL                    VRT006      3       12/10/05
QMGTC      12/06/05  9:27:27  *FULL                    VRT001      22      12/10/05
QMGTC2     12/06/05  9:27:27  *FULL                    VRT001      23      12/10/05
QPFRDATA   12/06/05  9:27:27  *FULL                    VRT001      24      12/10/05
QRCL       12/06/05  9:27:27  *FULL                    VRT001      25      12/10/05
QSRVAGT    12/06/05  9:27:27  *FULL                    VRT001      26      12/10/05
QS36F      12/06/05  9:27:27  *FULL                    VRT001      27      12/10/05
QUSRDIRDB  12/06/05  9:27:27  *FULL                    VRT001      28      12/10/05
QUSRIJS    12/06/05  9:27:27  *FULL                    VRT001      29      12/10/05
QUSRNOTES  12/06/05  9:27:27  *FULL                    VRT001      30      12/10/05
More...

```

Figure 6-49 Select Recovery Items using USEDUPMED(\*YES)

5. The virtual volumes will be shown when using this command:

```
STRRCYBRM OPTION(*CTLGRP) ACTION(*RESTORE) CTLGRP((DAILY))USEDUPMED(*YES)
```



## BRMS and virtual tape working from the Navigator

In this chapter we explain how to set up a simple backup using the i5 Navigator, and then run the backup. We also restore a single object from a backup taken with this setup.

We describe a setup for a virtual environment. Seen from the backup application perspective, there is almost no difference between the virtual tapes and the real tapes, in that both should have tape drives, tape volumes, the tape drive must be attached to the system, and so on. Backing up to a virtual environment is no different in that respect. The role of BRMS is to specify what to back up, how much to back up, where to write it, and then keep track of the result. We also explain how to retrieve the data, if needed.

Note that the setup instructions for BRMS that we provide in this chapter do not contain information about how to attach tape drives to your system. We also assume here that the required virtual image catalogs, virtual tape volumes, virtual devices and so on already exist.

The resulting BRMS set up in this chapter can be used for any tape environment, virtual or real. Only the policies used should be replaced.

## 7.1 BRMS and a brief introduction to virtual tape

The best way to understand how BRMS sees the concept of virtual tape is to disregard the term *virtual*. Think of it as though you are saving to ordinary tape volumes. The only difference is that virtual tape volumes reside in image catalogs and are not real physical objects. But the logic remains the same:

1. Take your backup.
2. Move the volumes to a secure place.
3. Bring them back for reuse when they are expired.

With virtual tapes, however, there is an intermediate step: copy the virtual volumes to real tapes.

In this chapter we show you how to create a simple backup for an application using the i5 Navigator. You can do the same thing in a 5250 environment.

A backup job normally writes data to tape volumes. Because the mission of BRMS is to keep track of those volumes, it has to know where all the tape volumes are, whether they are real or virtual.

Every volume must be in a *location*. If you do not place a volume in a specific location, BRMS stores them in a location called \*HOME, which is an undefined, catch-all repository. Real tape volumes are physical objects and must always be somewhere. Having them in meaningful locations is a much better alternative.

This chapter provides information about setting up BRMS for a virtual environment. Virtual objects exist, but you cannot move them around in the same way as physical objects. Yet, you have to set up your environment as though you can move virtual objects. BRMS sees a volume as a volume, whether real or virtual. The same rules apply to both real and virtual volumes.

A virtual tape is identical to a physical tape. The layout is exactly the same. When virtual tape volumes are duplicated to real media, there is a one-to-one match. This means that the type of virtual image you select must match what the hardware can accept. You cannot put an LTO cartridge in a QIC drive. It is the same with virtual media. If you have selected your virtual tape volume as an image of a LTO cartridge, you cannot copy that logical image to a physical QIC drive, because their layouts are different.

As always, the general rule is to keep everything as simple as possible. The process of recovering data should be kept simple and straightforward.

We strongly encourage you to familiarize yourself with the BRMS application, preferably by signing up for formal education. Before you attend a class, it is useful to refer to the appropriate IBM publications for self-study.

You may also wish to start up BRMS and try setting up and running a few example backups. Also, try to restore some of it. Recovery is the most important task of all; if you are unable to restore, there is little point to taking backups. If you combine BRMS classes on with some hands-on experience, you can immediately start asking questions and find it easier to follow the lectures.

Listed here are links to IBM services and training sites:

- ▶ IBM Rochester AS/400 Solution Center

<http://www-1.ibm.com/services/us/index.wss/offering/its/a1001549>

Also visit the IBM Services site for your geography to determine whether there are local services available.

- ▶ IBM Training Finder

<http://www.ibm.com/products/finder/us/finders?pg=trfinder>

## 7.1.1 Setting up locations

Follow the same setup sequence in the Navigator as you would in the 5250 emulation. Using the Navigator, you can do most of the setup in one shot, but it is easy to lose the overall picture. Therefore, in this chapter we show one function at a time, starting with setting up locations.

Why use locations? Locations are important because you need a clear picture about what to do with your backups after they are complete. BRMS must know where every volume is, and they have to be at a location, whether real or virtual.

Even volumes you have lost track of must have a home. You should, in fact, create a location called LOST (or other appropriate name). Tapes considered lost may show up again and if they contained vital data, you would not want to delete the information in the tapes just because you do not know where they are today.

At this point we assume that you know between which locations your volumes should rotate. For more information about that topic, refer to Chapter 2, “Planning for virtual tape” on page 9.

### Creating a location

To create locations as a sub-function under move policies, perform the following tasks.

Right-click **Move policies** and select **Manage Locations**, as shown in Figure 7-1 on page 332.

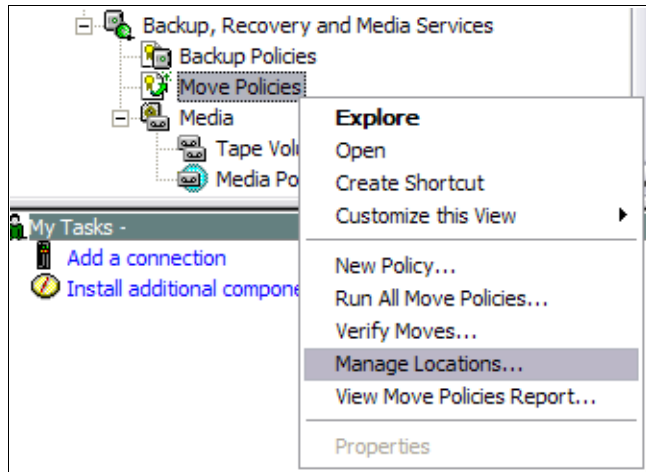

Figure 7-1 BRMS manage locations

This brings up the New Storage Locations panel, where you should fill in the following:

- ▶ Location name.
- ▶ A short description.
- ▶ The Address field is not really relevant for a virtual location. However, you can use it to tell, for instance, the purpose of this location, which ASP it refers to, and if there are any specific terms and conditions that apply to the location.
- ▶ Contact name, phone number, e-mail address do not really apply, but you can fill them in if desired.
- ▶ Specify whether to allow expiration or not.

You will require two locations:

- ▶ One for scratches and duplicated volumes that are not yet duplicated.
- ▶ One where the copied volumes await expiration before going back as scratches.

In this scenario, the names VIRTUAL and COPIED were picked. As their names indicate, they are used for virtual volumes. Being non-physical, virtual tapes are much more vulnerable to destruction than real tapes. Therefore, special precautions should be taken to shield them for being overwritten. They must stay intact until they are copied to real media. Therefore, in this scenario, they should stay in location VIRTUAL until copied. Do not allow anything to expire in this location.

This requires an explanation since in location VIRTUAL, all are scratch volumes. It sounds risky to have scratches and those that are not copied in the same place. However, this is not a problem because BRMS has to set an expiration flag

for each volume before reusing it, and location VIRTUAL does not allow expiration.

To achieve expiration, the volumes have to be moved to another location that allows expiration, for example, COPIED. Its sole purpose is to store all copied volumes until their expiration date is up. Allow expiration here. Once their time is up, the maintenance job in BRMS detects that they are overdue and sets the expiration flag. They can now be reused.

However, do not point any tape device to this location. In this scenario, the tape drives are all pointing to the scratch repository = VIRTUAL. The way the expired volumes find their way back to the scratch pool is decided by a Move policy. The following sections create two locations, VIRTUAL and COPIED.

## Location VIRTUAL

To create a location named VIRTUAL, perform the following tasks:

1. Fill in the Location name as VIRTUAL.
2. Give it an appropriate description.
3. The other text fields do not really apply to virtual volumes.
4. Deselect **Allow volumes to expire at this location**.
5. Click **OK**, as shown in Figure 7-2.

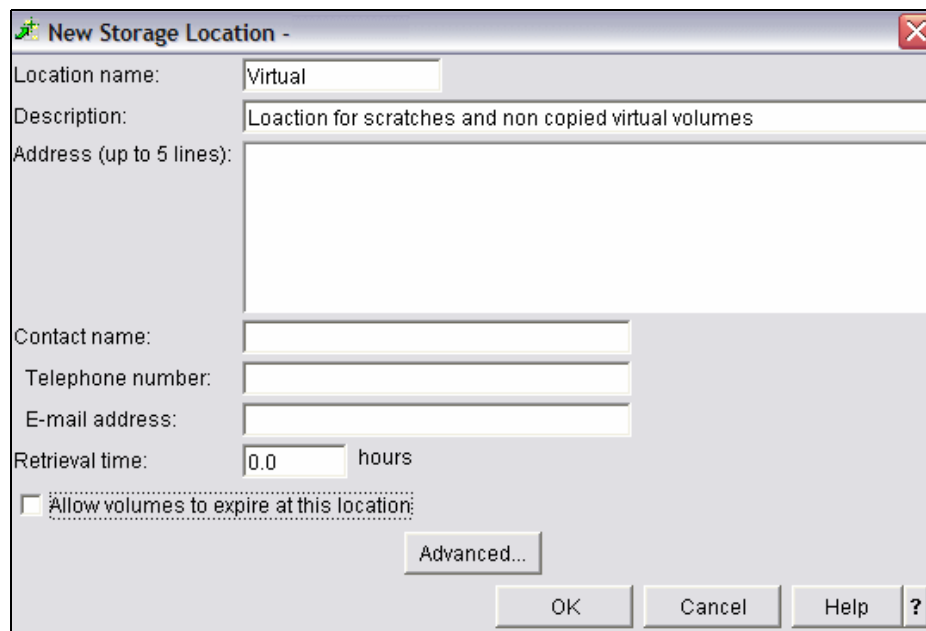

The screenshot shows a dialog box titled "New Storage Location -". It contains the following fields and controls:

- Location name: Virtual
- Description: Loaction for scratches and non copied virtual volumes
- Address (up to 5 lines):
- Contact name:
- Telephone number:
- E-mail address:
- Retrieval time: 0.0 hours
- Allow volumes to expire at this location:
- Advanced...
- OK
- Cancel
- Help
- ?

Figure 7-2 BRMS create location VIRTUAL

## Location COPIED

After creating location VIRTUAL, create another location where the virtual volumes start and return to after they have been duplicated. This location must allow expiration. Performing the following tasks:

1. Fill in the Location name as COPIED.
2. Give it an appropriate description.
3. The other text fields do not really apply to virtual volumes.
4. Deselect **Allow volumes to expire at this location**.
5. Click **OK**, as shown in Figure 7-3.

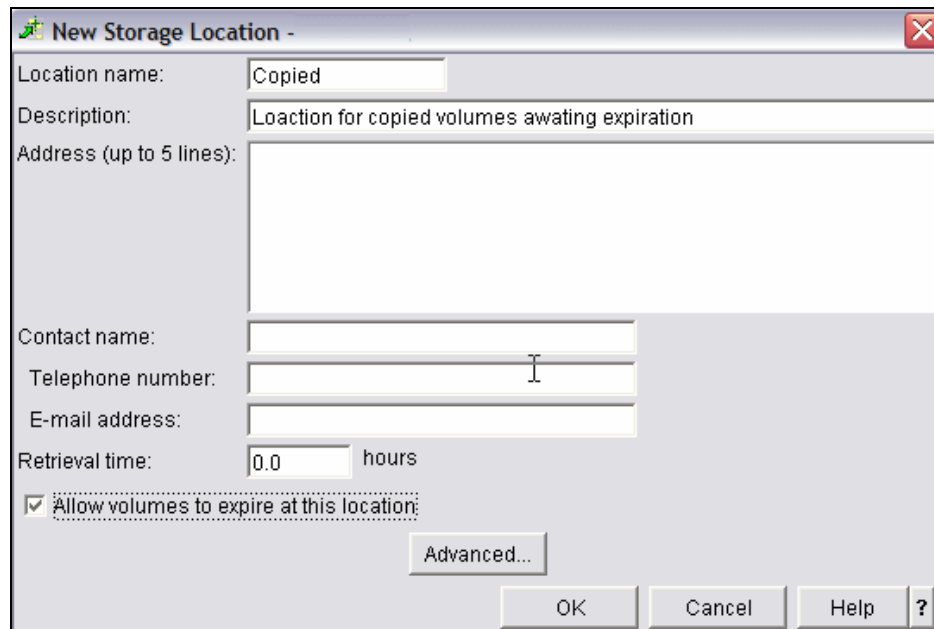

The screenshot shows a dialog box titled "New Storage Location". The "Location name" field contains "Copied". The "Description" field contains "Loaction for copied volumes awaiting expiration". The "Address (up to 5 lines)" field is empty. The "Contact name", "Telephone number", and "E-mail address" fields are empty. The "Retrieval time" is set to "0.0" hours. The checkbox "Allow volumes to expire at this location" is checked. At the bottom, there are buttons for "Advanced...", "OK", "Cancel", "Help", and a question mark icon.

Figure 7-3 BRMS create location COPIED

This concludes the processes involved in creating two locations, VIRTUAL and COPIED.

**Note:** A location exists only within BRMS. The actual image catalog with its virtual tape volumes is in an ASP somewhere. BRMS only points to where the tapes are, as for real tape volumes. The reason for having information about a location is for recovery purposes. When disaster strikes, there is no time for “hide and seek”. Everything has to go in a straight line without deviations, preferably in several parallel paths to reduce downtime. Therefore, ensure that the names you use are as self-explanatory as possible, and fill in the text and comment fields whenever possible.

**Important:** Your recovery procedure is not worth anything until it is tested and verified. Sign up for a recovery test with a BCRS provider.

## 7.2 Defining a move policy

What is the requirement for move policies? That's an interesting question, especially since these volumes are virtual and cannot move physically.

Although this is true, logically they can be moved. You may, for instance, want to move the backups you want duplicated to a specific location, say, `NOT_COPIED`. After they are duplicated, they move back, awaiting the end of their retention period. By doing so, you avoid having them overwritten until they are duplicated, although their retention period may be up. Although that seems logical, you have to do it the opposite way.

As explained in “Creating a location” on page 331, the volumes should be shielded until they are copied. This can be achieved by keeping them in the location `VIRTUAL`, which does not allow its volumes to expire. When they are duplicated, they can then go to the next location, awaiting the end of their expiration period. In reality, nothing moves. It is only a logical movement. The virtual volumes stay in their image catalogs.

After a volume is used for output, BRMS turns off its expiration flag. From then on, this volume can only be used for adding data to its end until the expiration flag is set again. Every volume has an expiration flag, as does every location. By using these flags, you can achieve what you want.

Once you set the location expiration flag to off, it means “no, it does not matter if the volumes in there have passed their retention period end”. Their expiration flags will never switch to on; that is, the volumes are considered available for reuse, as long as they are in this location. As long as they are there, they are safe unless you delete them manually, which is a safety exposure. With real tape volumes, some amount of physical activity is required to destroy a tape. With virtual volumes, they are gone within a click or two of the mouse.

You should reuse your tape volumes, but not until they are copied. Otherwise, your disk will fill up. As a result of duplication, they move to another location. That location allows expiration. If their retention period is already up, BRMS will, by using the move policy, move them back as scratches. If not, they will wait until that day comes. BRMS moves only those volumes that meet the moving criteria.

Typically, a virtual volume is used for quick restore. For example, you save them for three days, while the duplicated copy or the real tape can have a retention period of weeks, depending on the use.

**Note:** You can create locations as a sub-procedure when creating a move policy. For clarity, you can create them as separate tasks.

In this chapter we assume that all locations required for this example already exist; refer to 7.1.1, “Setting up locations” on page 331. If they do not, you can create them as you go along.

Two move policies are required to achieve your goal:

- ▶ One move policy should move the tapes to a location awaiting retention end after they are copied, and then back again.
- ▶ Another move policy should specify what to do with the results of the copying (that is, the real tapes).

Name the first move policy TO\_COPY. Although TO\_BE\_DUPLICATED would be a better name, since you can have only ten characters for a name, you can shorten the name to TO\_COPY.

**Note:** You could give your move policy the same name as the location. However, to avoid confusion, name them differently.

## 7.2.1 Creating a move policy

To create a new move policy, perform the following tasks:

1. Right-click Backup Policy and select **New Policy**, as shown in Figure 7-4.

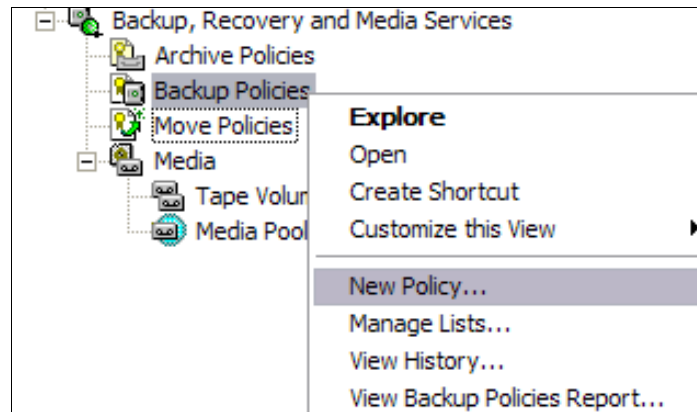

Figure 7-4 Create new move policy

2. In the window that appears, as shown in Figure 7-5, fill in the policy name as TO\_COPY.

3. In the Description field, describe what it is used for, then click **Next**.

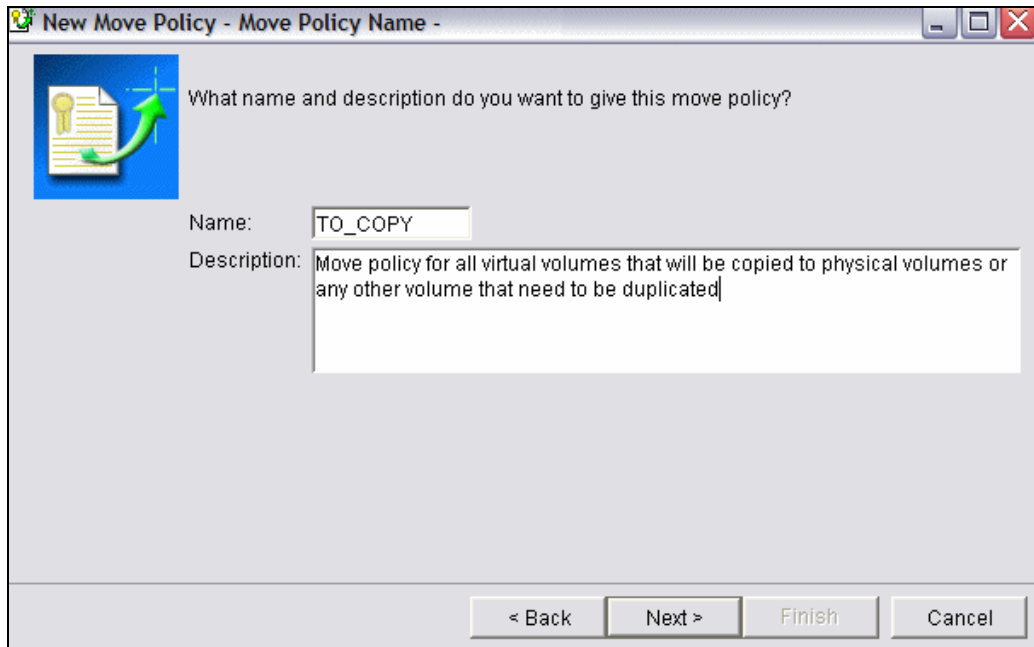

Figure 7-5 New move policy

The example backup in this scenario is simple. After the backup writes to a virtual volume, it should be copied to physical media. Once done, move the virtual volumes to a place where they stay until they get expired. That location is COPIED. When the expiration flag is set, they return to their starting place, which in this case is location VIRTUAL.

All this is controlled by the move policy you force to your written volumes by the media policy\* you use. Of course, you could do without a move policy. Everything can be moved manually if you prefer it that way. However, in this example, a move policy is used.

**Note:** When working from the Navigator, you will not see any media policy as you do in 5250 emulation. This function is taken over by the move policy.

From any location, a volume with this move policy will move in the following order:

- From where it started to location COPIED.
- When the expiration flag is set, they move back awaiting reuse (in) this example, location VIRTUAL.

4. Mark location **COPIED**.
  - a. Click **Add After** or **Add Before**.
  - b. Finish by clicking **Next**, as shown in Figure 7-6.

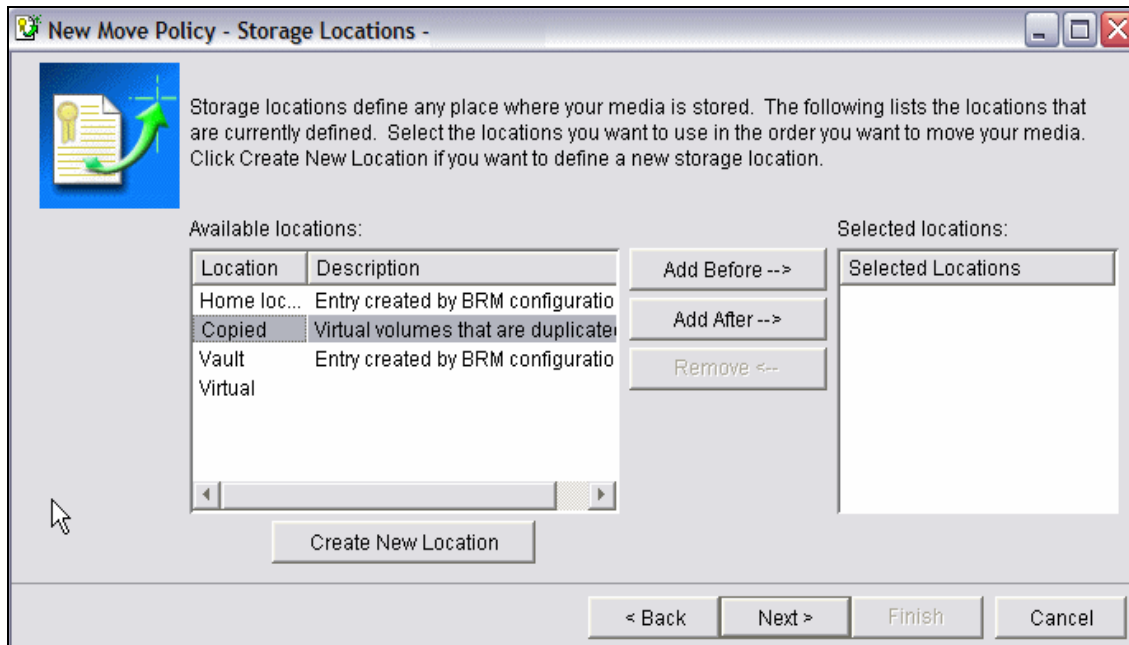

Figure 7-6 Select locations

For each location, set the duration for which the volumes will stay in each place. In this scenario, with virtual volumes, there is only one place to define as they stay at location **COPIED** until expiration time is up.

5. Ensure that Duration states **Until** media expiration date, and click **Next**, as shown in Figure 7-7 on page 339.

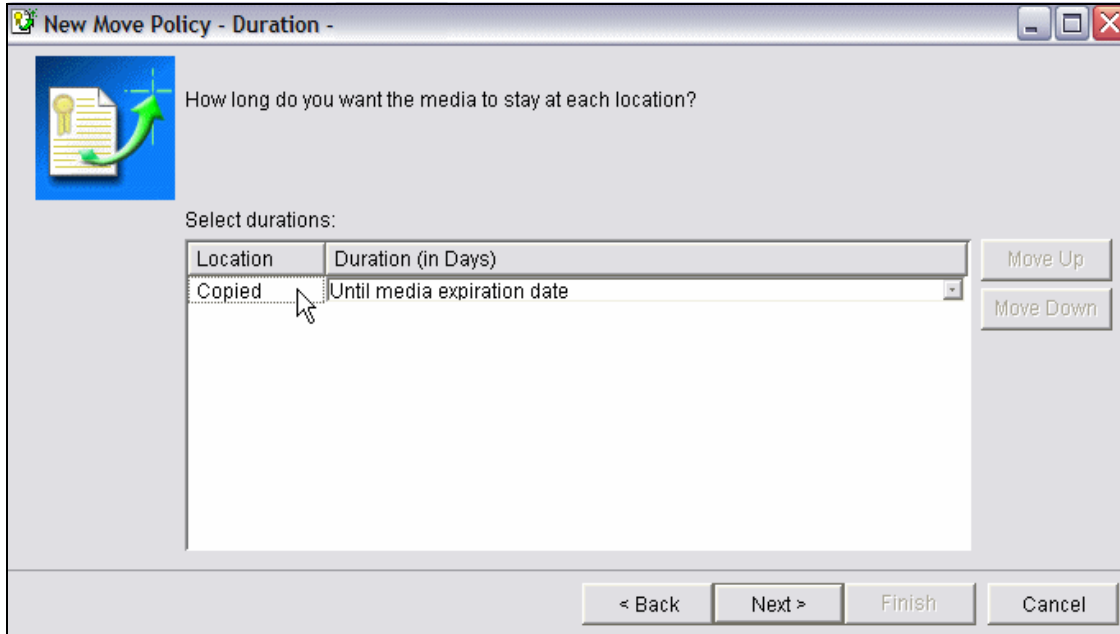

Figure 7-7 Specify days at each location

6. Before the move policy is complete, you also choose whether to verify all movements, or if the volumes will move without manual intervention.

As mentioned previously, when moving virtual volumes, there is little meaning in verifying movement as it is only a logical movement. Nothing moves physically, so the recommendation is to skip that.

However, you could choose Yes if you want to verify if everything is moved as expected. In this scenario, however, we will trust BRMS and say No, we do not verify, so select **No** and click **Next**, as shown in Figure 7-8 on page 340.

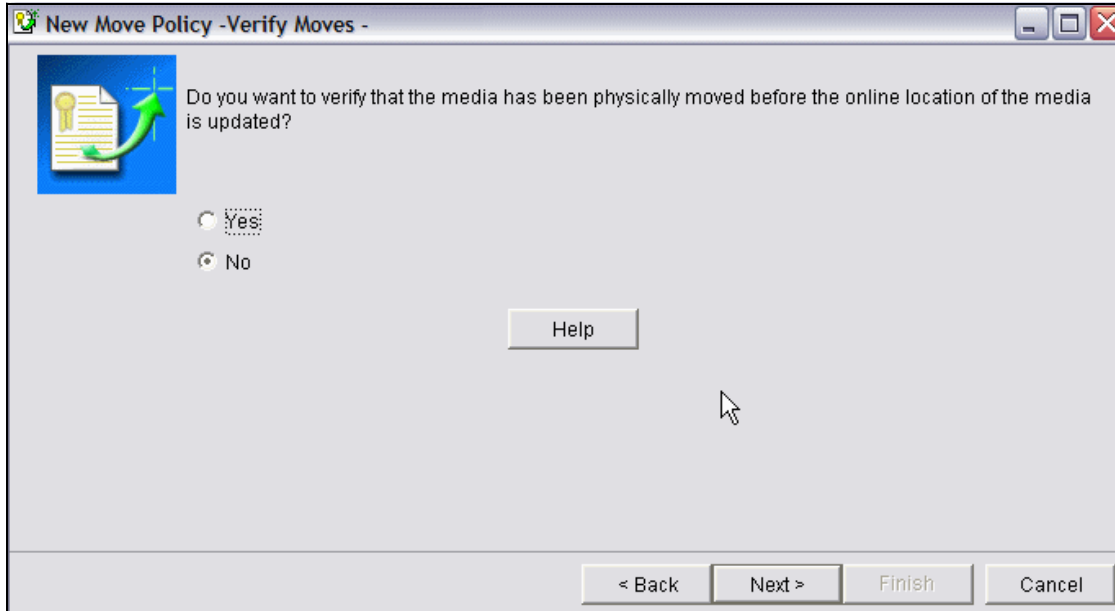

Figure 7-8 Verify movements

**Note:** BRMS release 5.4 expires a volume based on the expiration date only. There is no check on whether a volume marked for duplication really got copied or not. This may change in a future release.

7. In the window that appears, you can apply this new move policy to any existing backup and archive policy. However, at this point, you cannot do that because you have not yet created any backup policy.

Therefore, continue to the last window by clicking **Next**, as shown in Figure 7-9 on page 341.

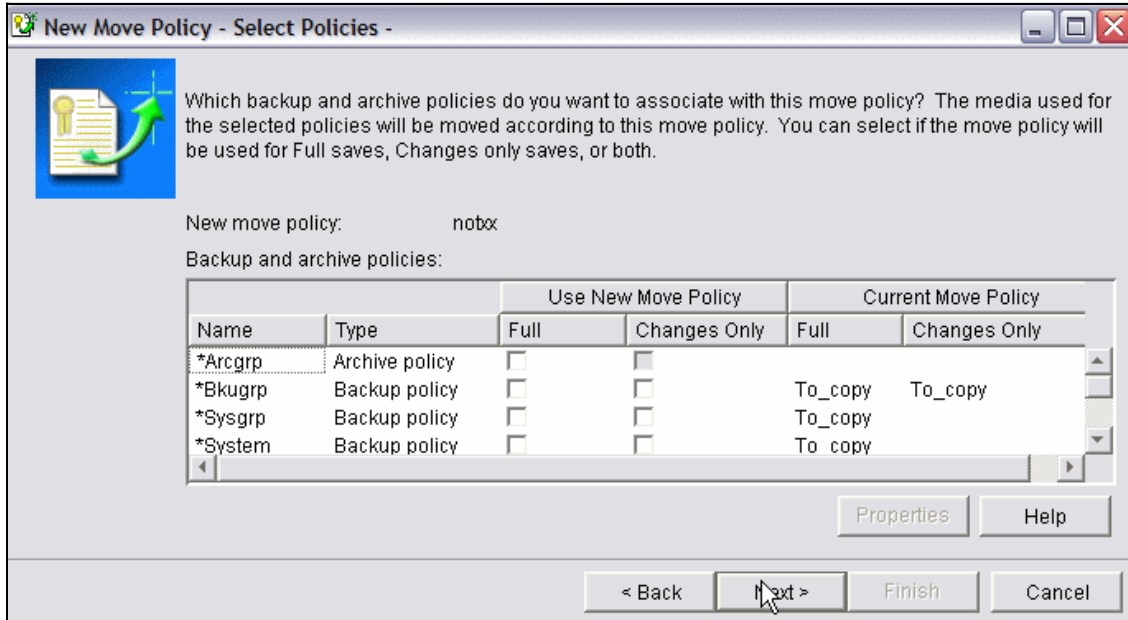

Figure 7-9 Select backup policy

- The final window shown in the create move policy setup is a summary of the settings, as shown in Figure 7-10 on page 342. Since all the actions are complete, click **Finish**.

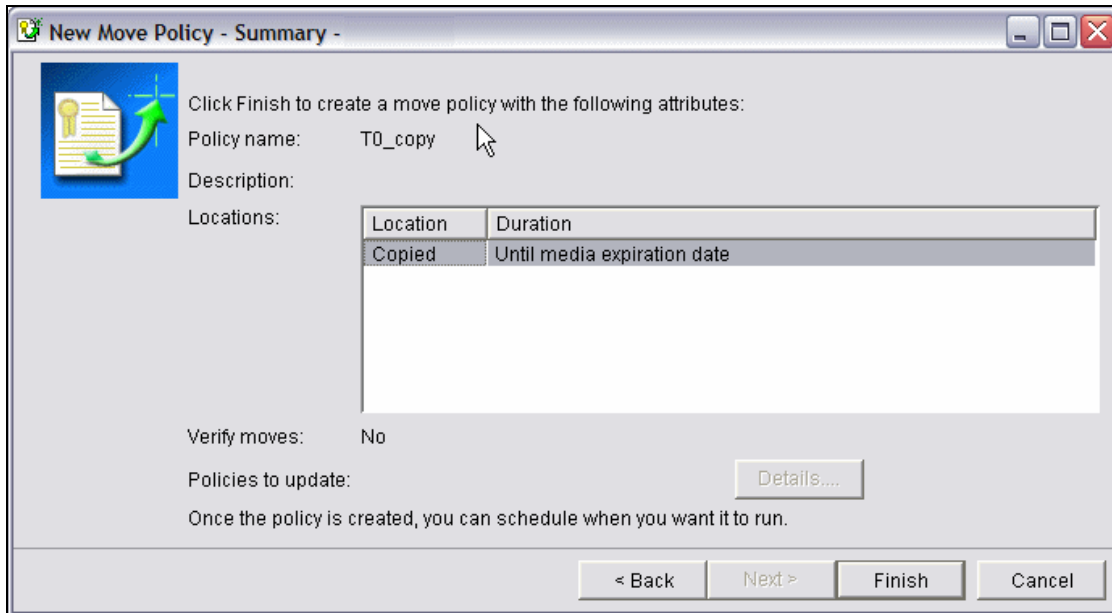

Figure 7-10 Summary

9. The new move policy is now created. Back at the Navigator, press F5 to refresh.

### Changing the created move policy

When creating the move policy, there was nowhere to specify what would happen after the end of the move chain, that is, from VIRTUAL to COPIED. However, after that, you require the virtual volumes to flow back to VIRTUAL so that they can be reused.

BRMS assumes that volumes return back from where they came. That is fine as long as the volumes start from location VIRTUAL. However, if they do not, you should ensure that they always find their way to VIRTUAL when they are free for reuse. For this, make a slight change to the move policy.

1. Right-click your move policy **TO\_COPY** and select **Properties** as shown in Figure 7-11 on page 343.

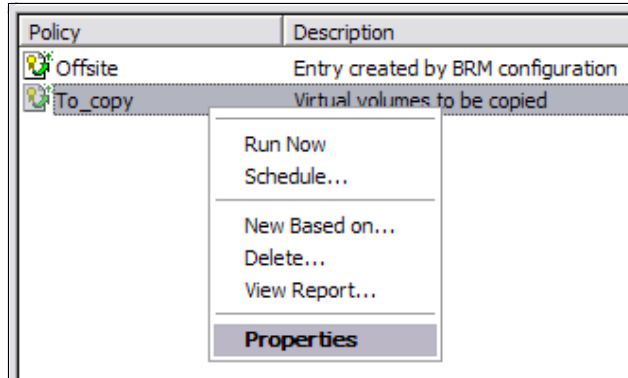

Figure 7-11 Properties

2. Figure 7-12 shows that the move policy has two tabs:

- General
- Locations

Click **Locations**. Click **Browse**, select location **VIRTUAL**, then click **OK**.

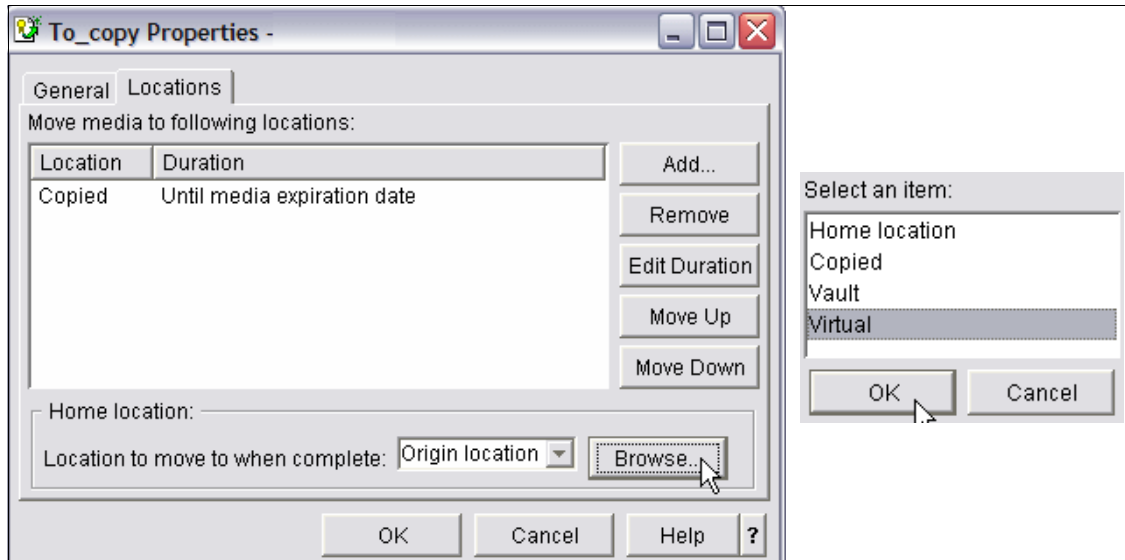

Figure 7-12 Change return location

Your move policy for virtual volumes is now complete and ready to use.

## 7.2.2 Move policy for physical tape volumes

Creating a production environment also requires a move policy that specifies what will happen to the data after it is copied to the physical volumes.

### Move policy OFFSITE

Fortunately, BRMS has already created such a location and a move policy pointing to that location.

- ▶ The location name is VAULT.
- ▶ The move policy is OFFSITE.

Tailor these to your needs, preferably copying them with your own naming convention to prevent future application updates from changing them back to their original state. In this scenario, OFFSITE was used without changes.

**Tip:** Keep everything as simple as possible.

Move policy OFFSITE will be used by the media duplication process DUPMEDBRM.

In this scenario, we used the move policy BRMS created during the installation process.

**Note:** While working with the BRMS graphical interface, you will see buttons that facilitate a number of combinations. In the midst of creating something, you can take a sidestep to create other things, and then get back to what you were doing initially. There are different ways of achieving a desired result. For simplicity, in this chapter we follow a straight line in order to make the concept more understandable.

## 7.3 Designing a tailored backup policy

In this section we explain how to create a simple backup for a specific application. Because this application stores its data in i5 libraries, you do not have to deal with data in the Internal File System (IFS), which of course is also possible to set up for backup.

This section covers the following topics:

- ▶ What to save
- ▶ Where to save it
- ▶ Setting a duration for the saves
- ▶ Physical media to store on

## What to save and where to save

1. Create a backup policy by right-clicking Backup Policy and selecting **New Policy**, as shown in Figure 7-13.

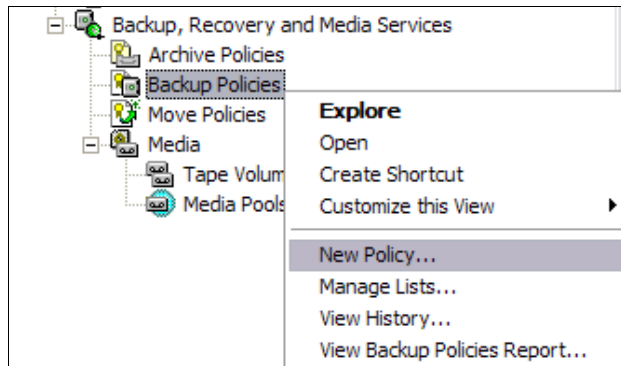

Figure 7-13 Create a new policy

1. Save all the ITSO libraries (their names start with DBITS0). Fill in the backup policy Name and Description, as shown in Figure 7-14 on page 346 (in this scenario, the policy is named ITS0DB).

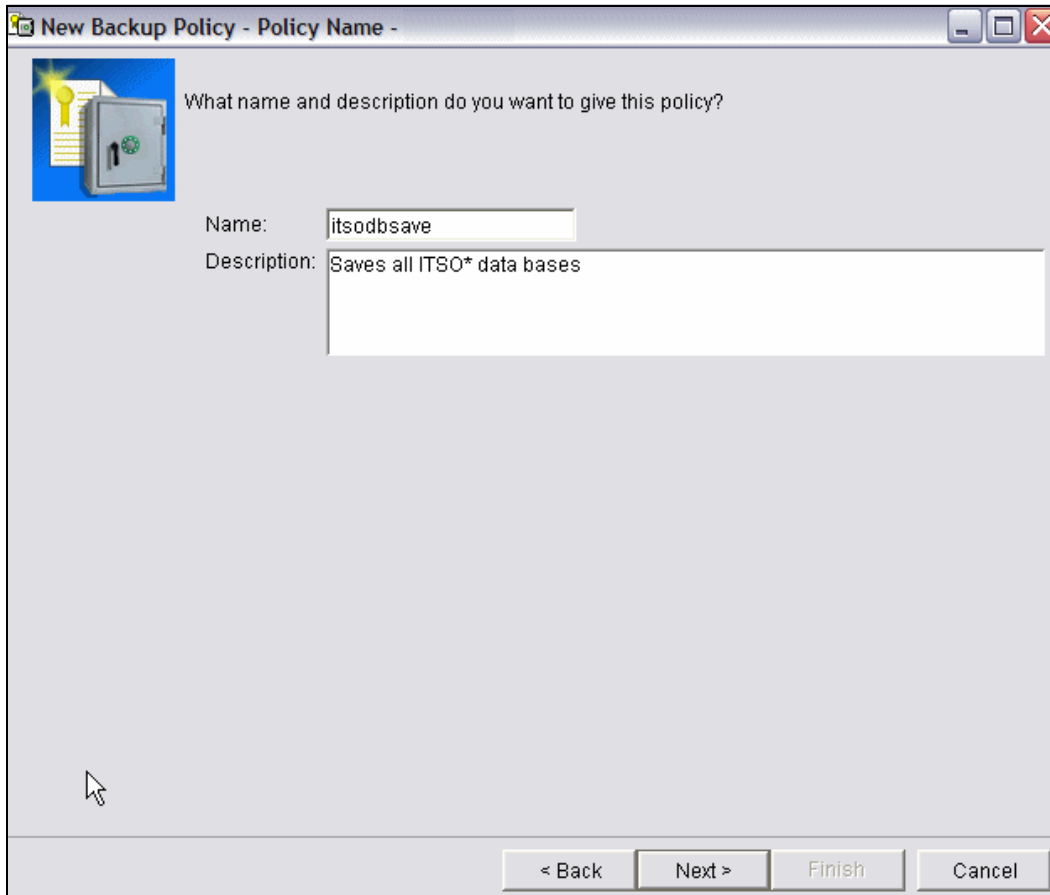

Figure 7-14 Create a policy name

2. In the Select a Save Strategy window shown in Figure 7-15 on page 347, there are three selections:
  - Save all system and user data equal to a so-called “21-backup”.
  - Save all user data is an \*ALLUSR backup.
  - Save Lotus server data or customize sets of objects.

You only have to save the selected libraries. Select **Save Lotus server data or a customized set of objects**, and then click **Next**.

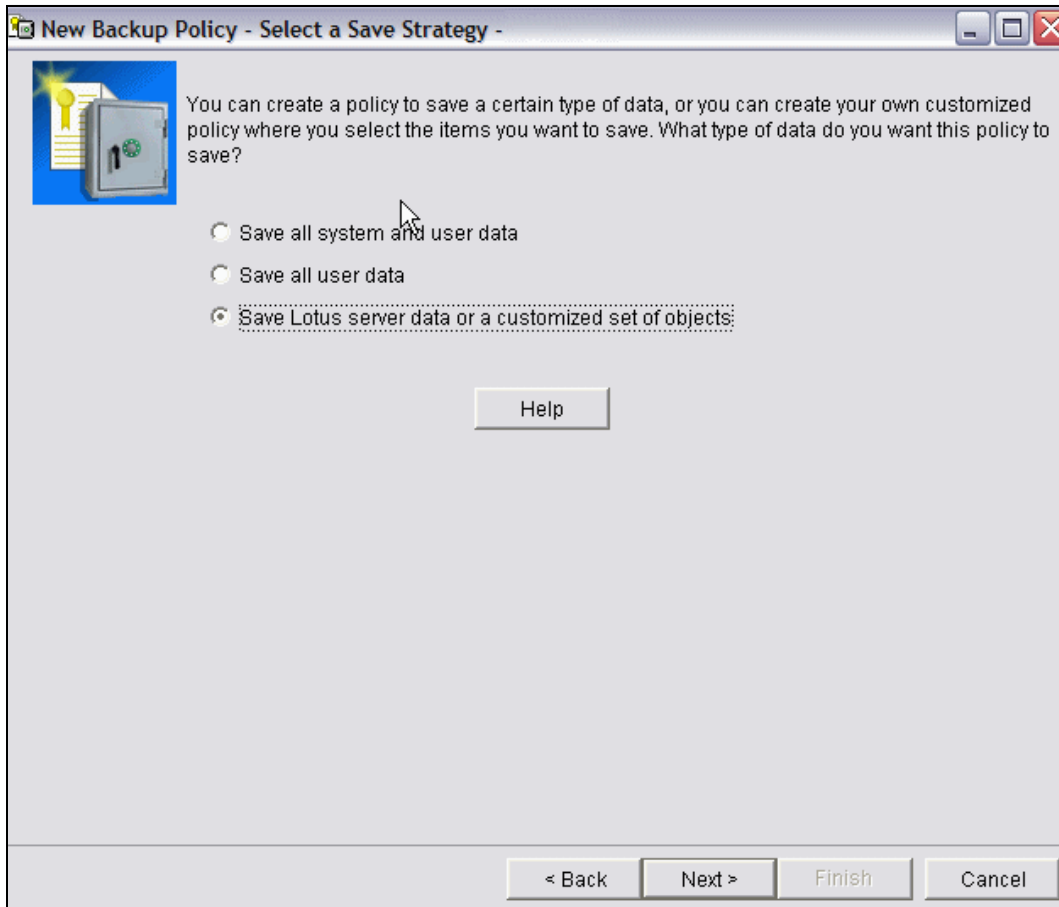

Figure 7-15 Select a save strategy

3. The window shown in Figure 7-16 on page 348 asks if you want to save IBM-supplied data or user data. Select **User data** and click **Next**.

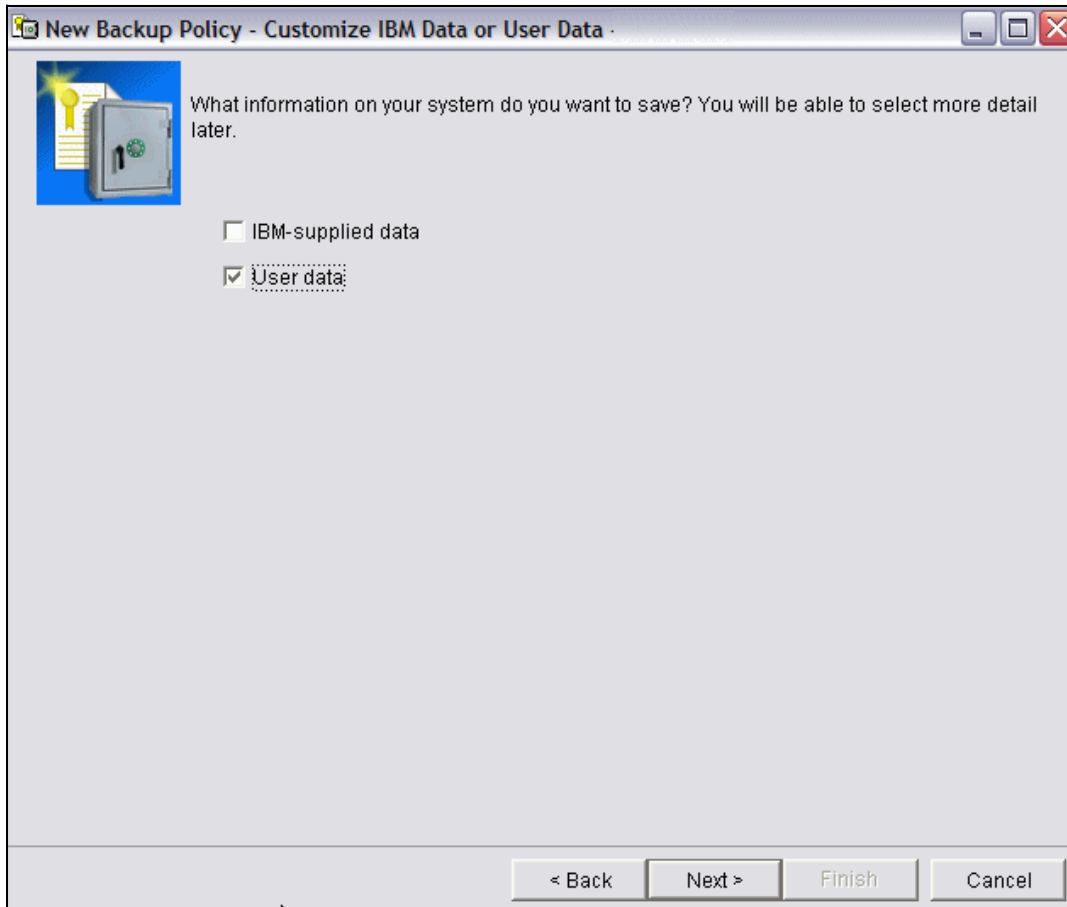

Figure 7-16 Customize IBM-supplied data or user data

4. The Customize user data window shown in Figure 7-17 on page 349 appears. This is a pick and choose concept. Choose **Select specific items to save**, and click **Next**.

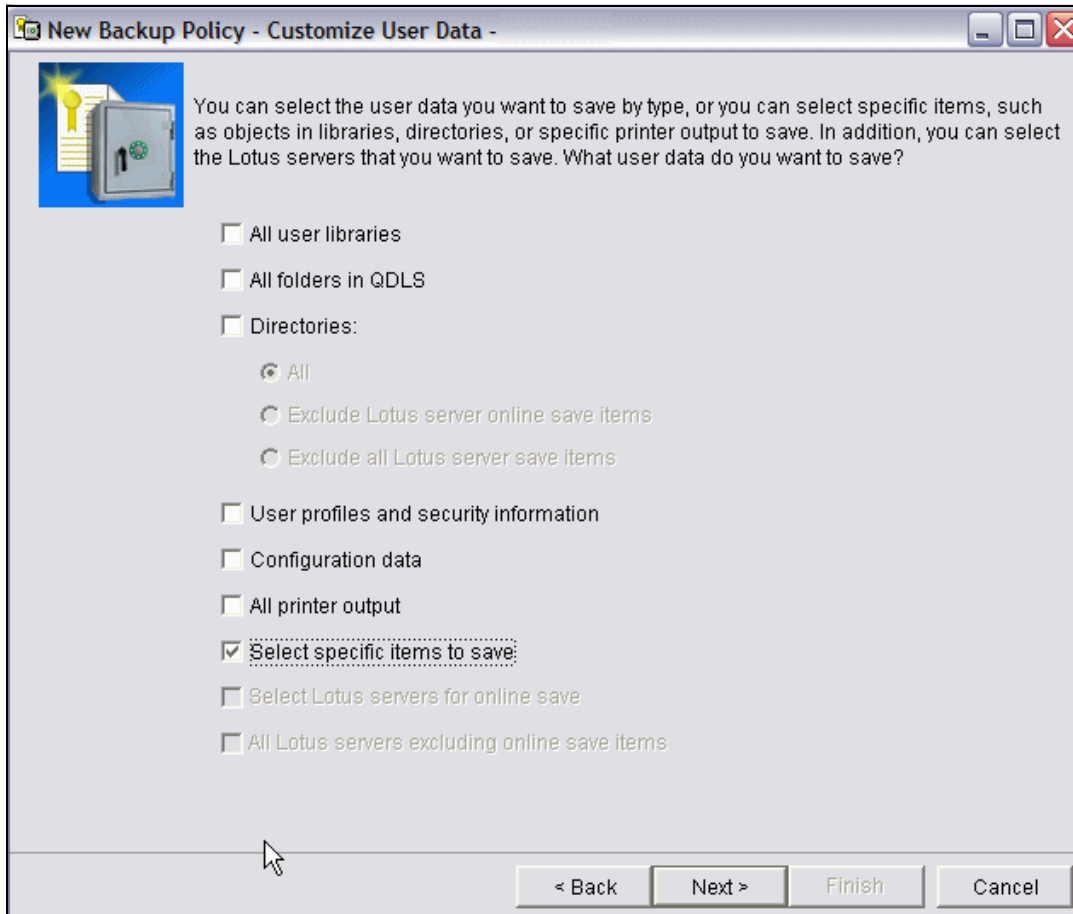

Figure 7-17 Customize user data

5. In the window shown in Figure 7-18 on page 350, you can select either of the options. In this scenario, select **Specify Generics...**, and then click **Next**.

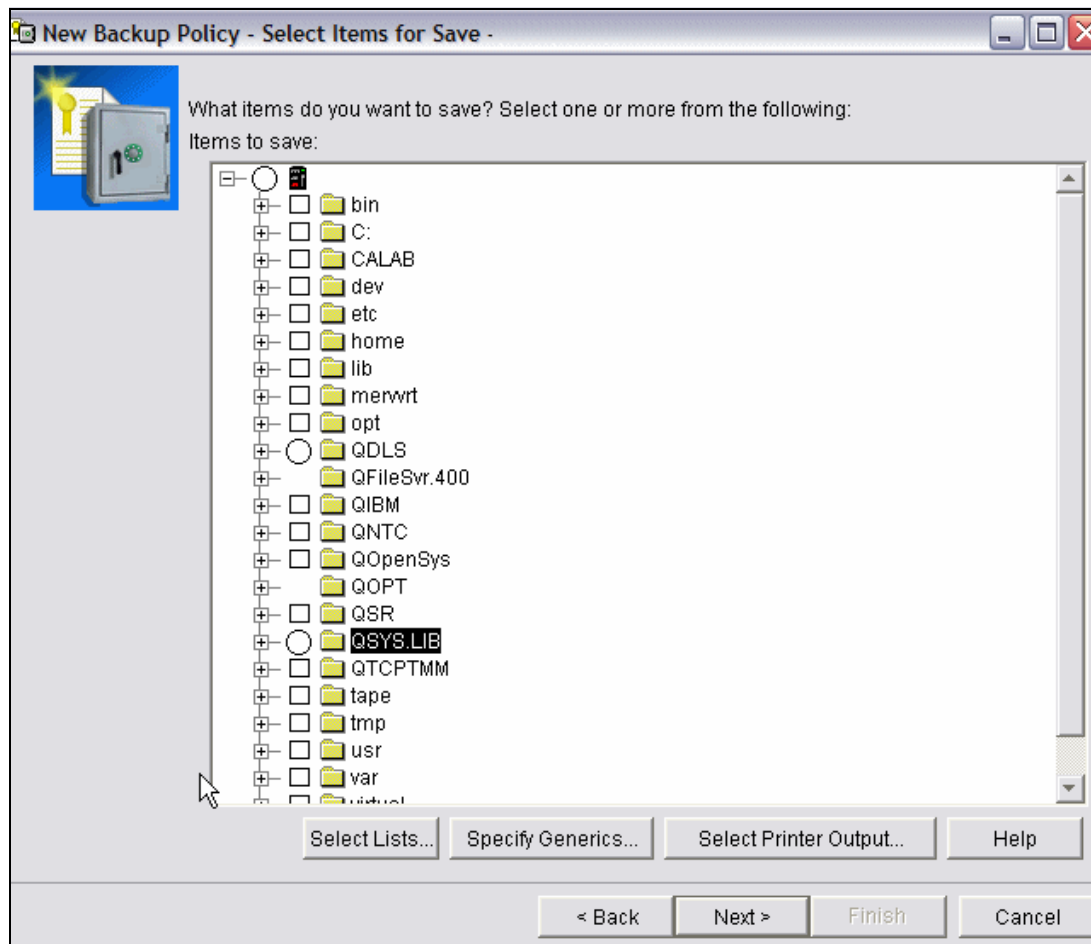

Figure 7-18 Select items for save

6. Under the generics shown in Figure 7-19 on page 351, select **Libraries** and click **OK**.

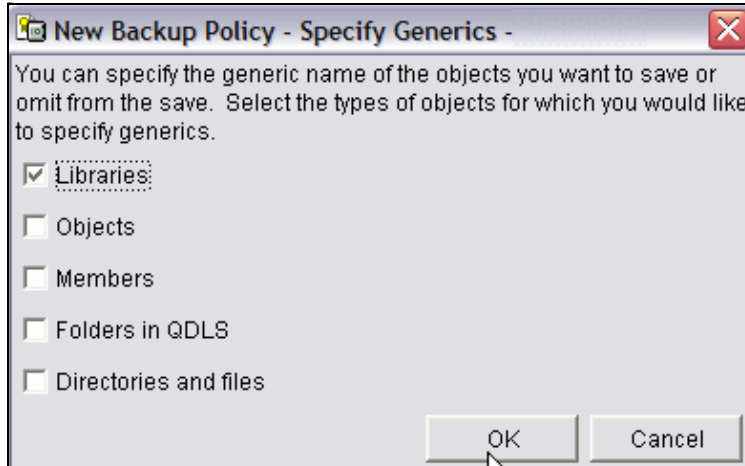

Figure 7-19 BRMS backup policy - specifying generics

7. Finally, in the window shown in Figure 7-20, add the libraries you want to back up. Click **Add** and input the value DBITS0\*, then click **OK**.

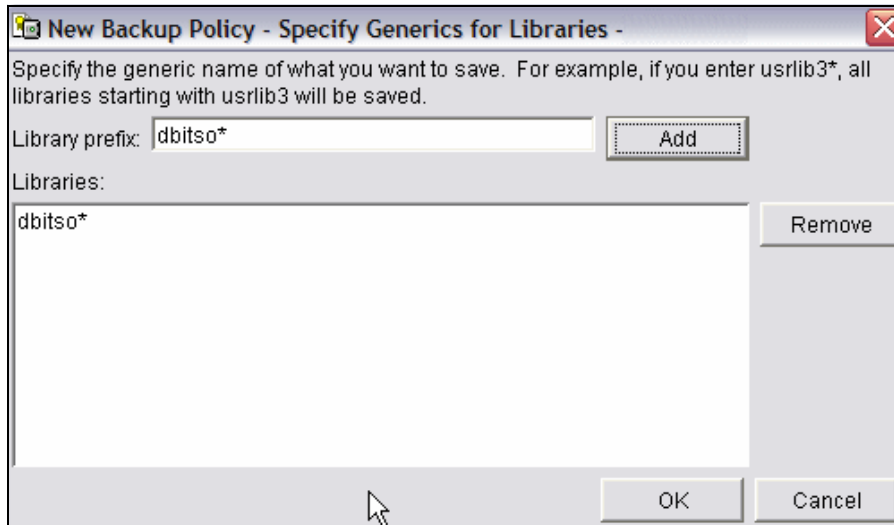

Figure 7-20 Customize user data

8. You are taken back to the first selection window, shown in Figure 7-21 on page 352, to add more objects to save. You are finished, so click **Next**.

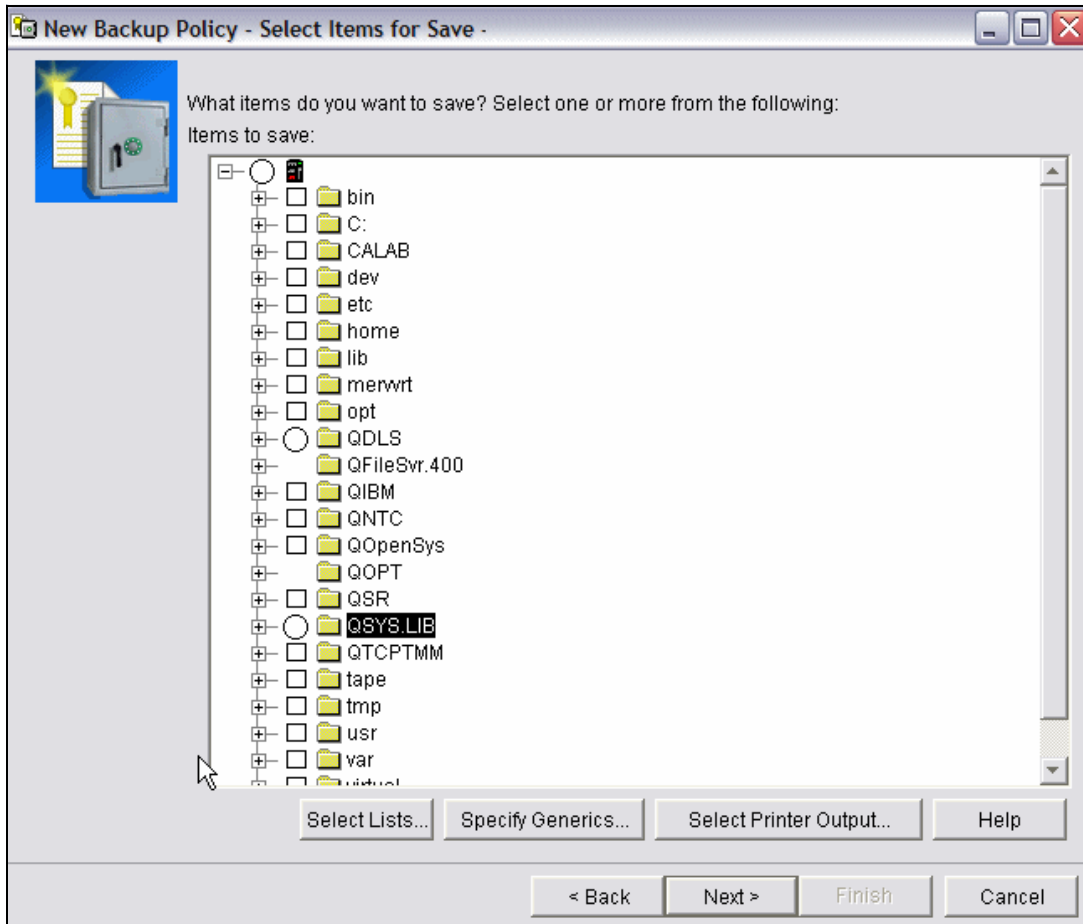

Figure 7-21 Select items for save

### How much should be saved

The example databases of this scenario are not updated frequently. Therefore, we decided to back up changes only. This gives a quick daily backup. To get an easy recovery, these changes were also selected to be a cumulative backup. By doing so, you will need only two volumes for recovery.

If you plan to let your data stay as virtual volumes only (which is possible, but not recommended), you could choose the changes since the last backup option. This means you will have one backup set for Monday, another for Tuesday, and so on.

We recommend this option only if you have a tape library or, as in this case, virtual volumes. Otherwise, a full recovery becomes difficult because of all the

tape mountings unless you are 100 % sure that it will be the same files that get updated every time.

To create a change backup, the operating system should have a starting point so that it understands what is changed. That is, the base is a full backup.

However, you do not have to first create a backup policy as a full backup and then go back and flip it to changes only. BRMS is smart enough to convert your request for changes only to a full backup if there are none.

To create a change backup, follow these steps:

1. In the window shown in Figure 7-22 on page 354, select **Changes only**, **Changes since last full save (cumulative)**, and **Allow overrides at run time** (this option allows you to make changes to whatever is saved without having to change the backup policy), and then click **Next**.

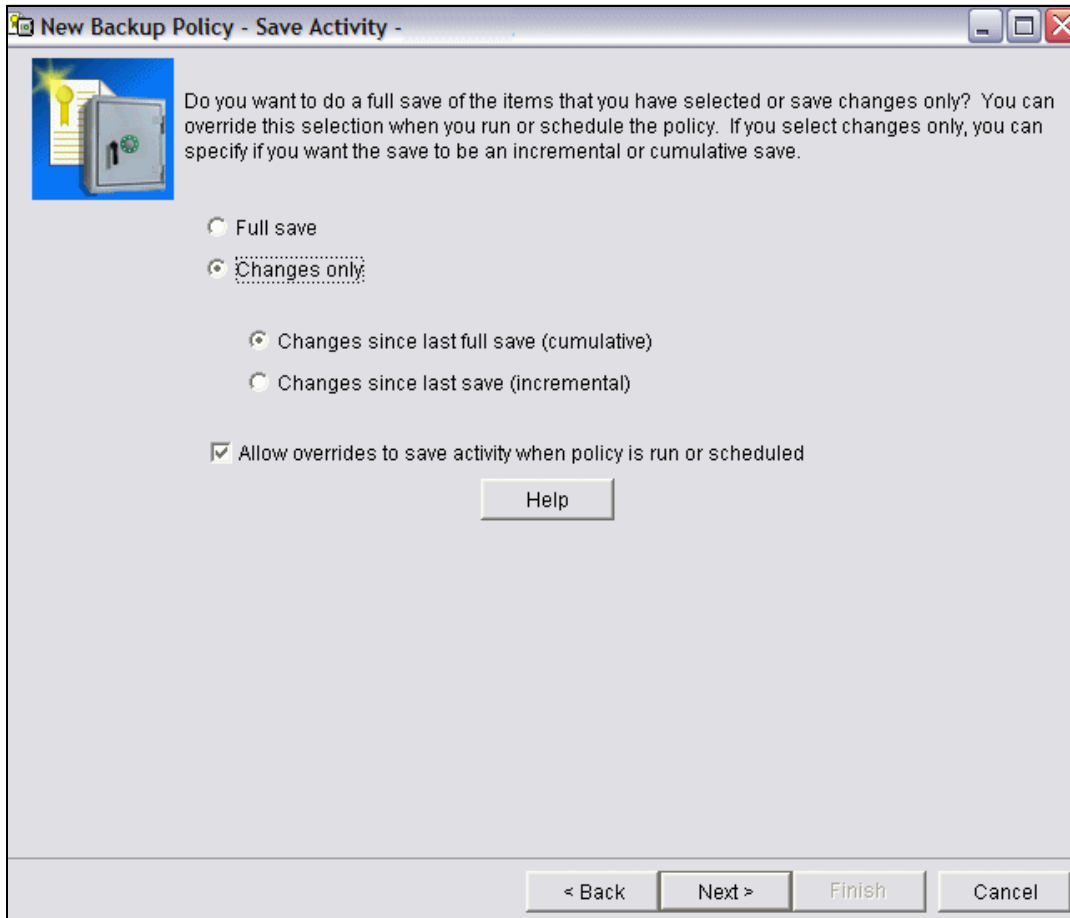

Figure 7-22 Save activity

2. Saving to virtual media emulates real physical tape volumes exactly. A tape image on disk must exist. Although you are backing up in a virtual environment, you are, in fact, saving to media.  
Select **Save to media** and click **Next**, as shown in Figure 7-23 on page 355.

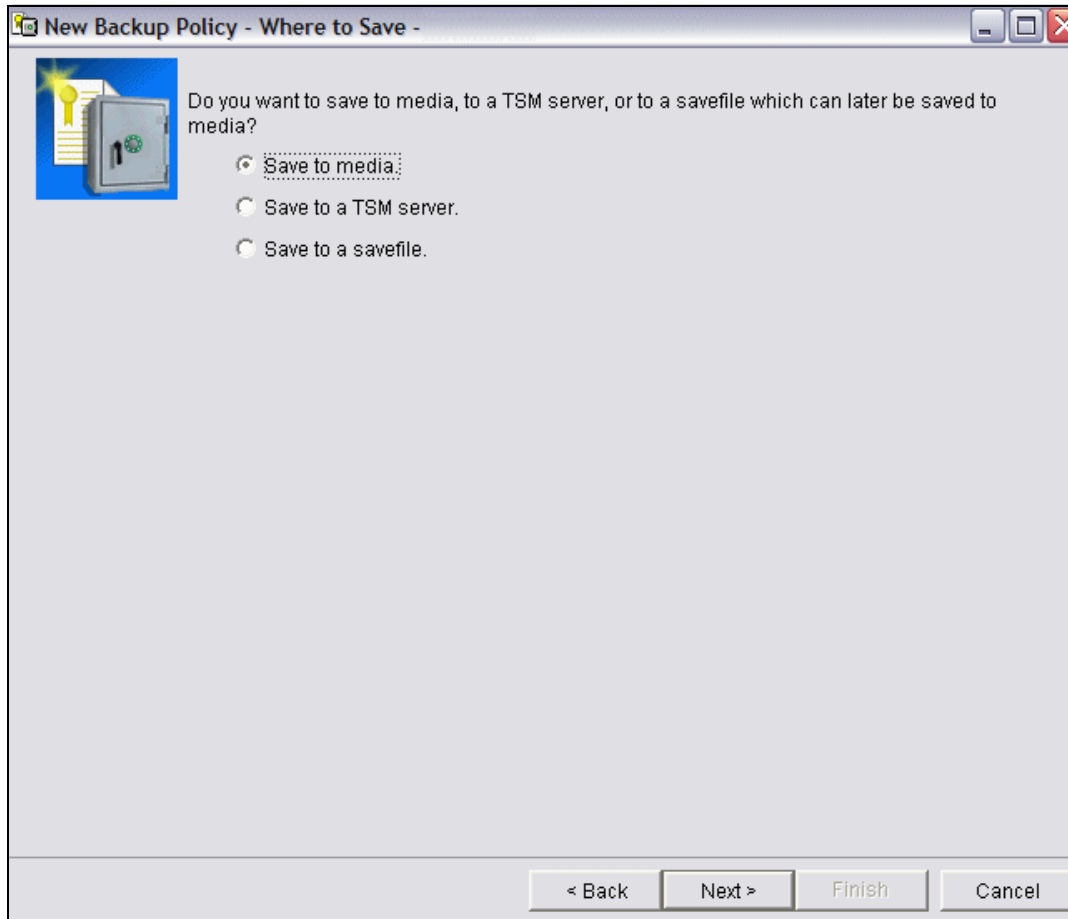

Figure 7-23 Where to save

### Setting a duration for the saves

To save data for least two weeks, set your retention period to, for example, 17 days, in order to cover the weekends. However, remember that you are backing up to virtual volumes. Therefore, after they have been copied to real tape volumes and are not needed for immediate recovery, you have to only shield them from being overwritten for a few days.

As a result, you can set the retention period to three days. If you want cover for long weekends and have enough disk space, you can set this value to be a little longer.

1. In the window shown in Figure 7-24 on page 356, select **Days**. Input the value 3 for the field Days. Select **Allow overrides...**, and then click **Next**.

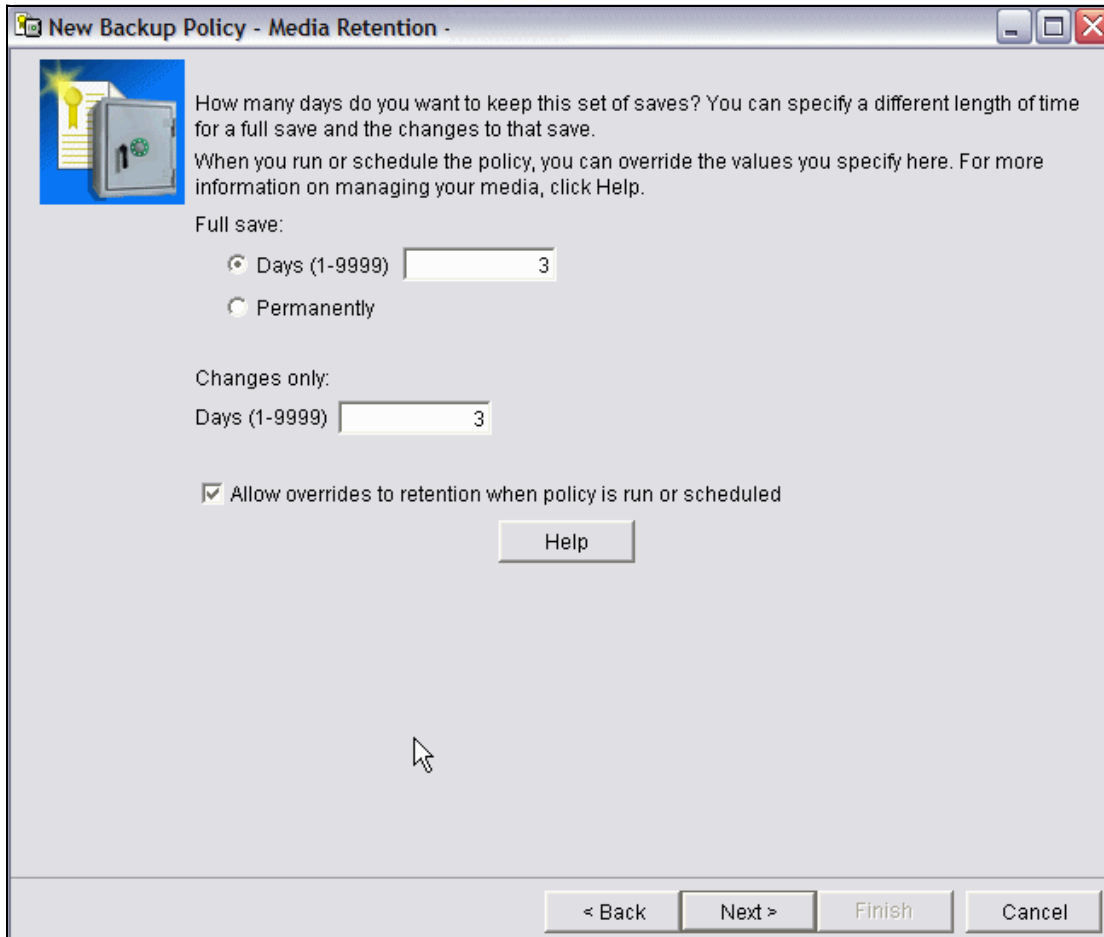

Figure 7-24 Media retention

### Physical media to store on

The example system in this scenario has no tape library, only two QIC tape drives. Since they are of different models, select the lowest possible density. While this is the worst choice from a performance perspective, it does give you the freedom to copy your virtual volumes to any of those two drives. Select what suits your needs best, performance versus flexibility.

1. Select the media pool you want to use in the window shown in Figure 7-25 on page 357. Select **Vrt32k** against Media pool.

When the Vrt32k media pool is chosen, BRMS automatically presents the virtual tape drives that can use this density. We select those we find reasonable. There can be up to 35 virtual drives active at the same time, tape

and optical. Depending on how many backups you plan to run simultaneously, you select whatever suits your needs. In this example we only need TAPVRT01.

Select **Tapvrt01**, and click **Add**.

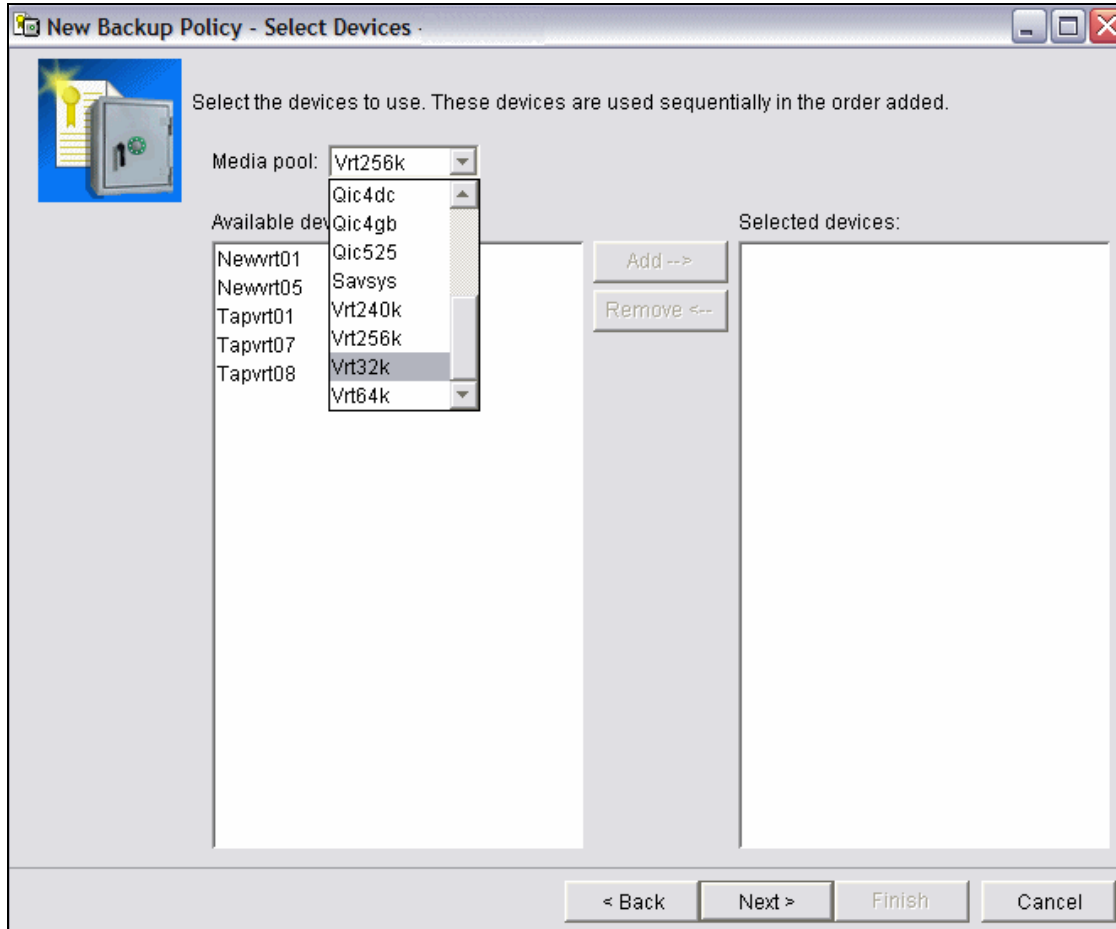

Figure 7-25 Select media class

**Note:** If your tape device is not listed but you can still see a device description from the i5 operating system, it means BRMS is not aware the device. Run `INZBRM *DEVICE`, which picks up all existing tape drives. For more information about this topic, refer to 7.10, "Adding a new tape drive to BRMS" on page 427.

2. Click **Next**, as shown in Figure 7-26.

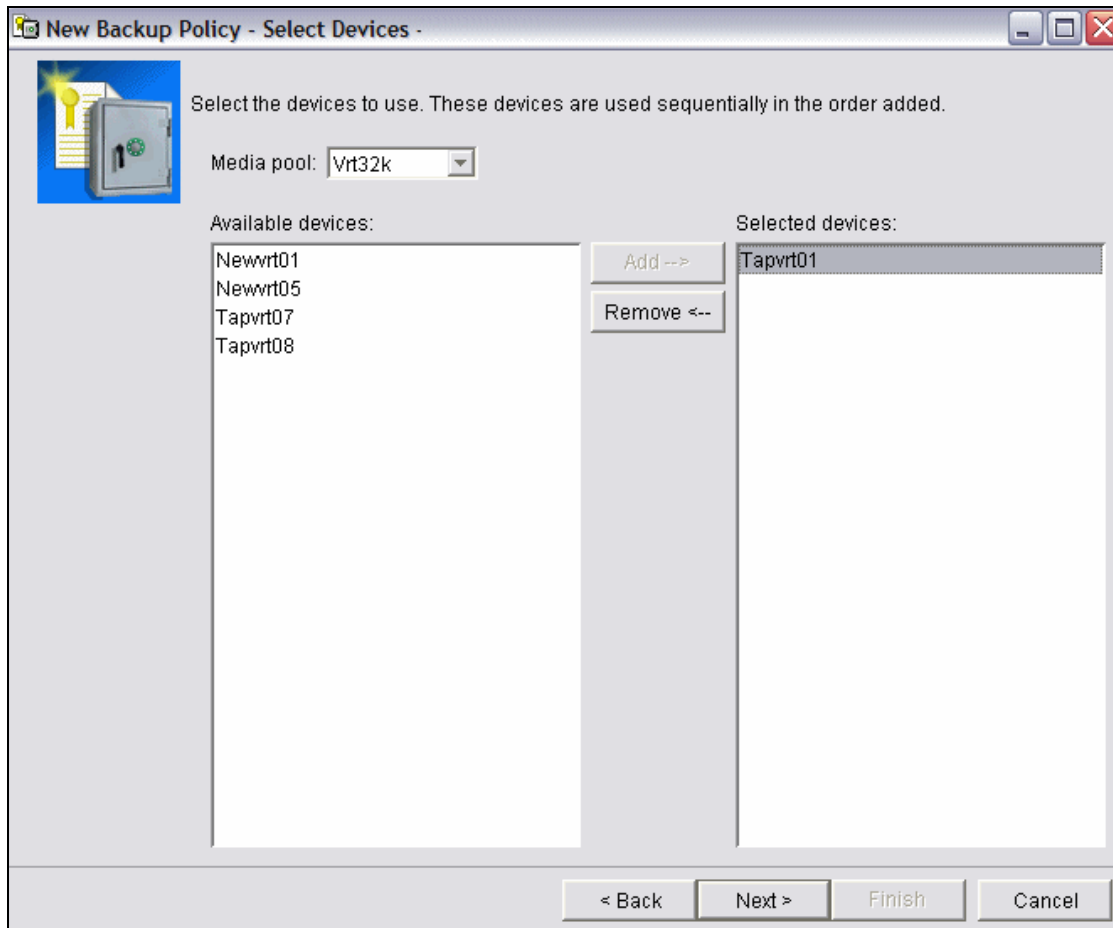

Figure 7-26 Select devices

3. Now decide whether to copy your volumes to physical media. In this scenario, since backups are written to virtual volumes, you should.

In the window shown in Figure 7-27 on page 359, select **Yes, mark the media for duplication**.

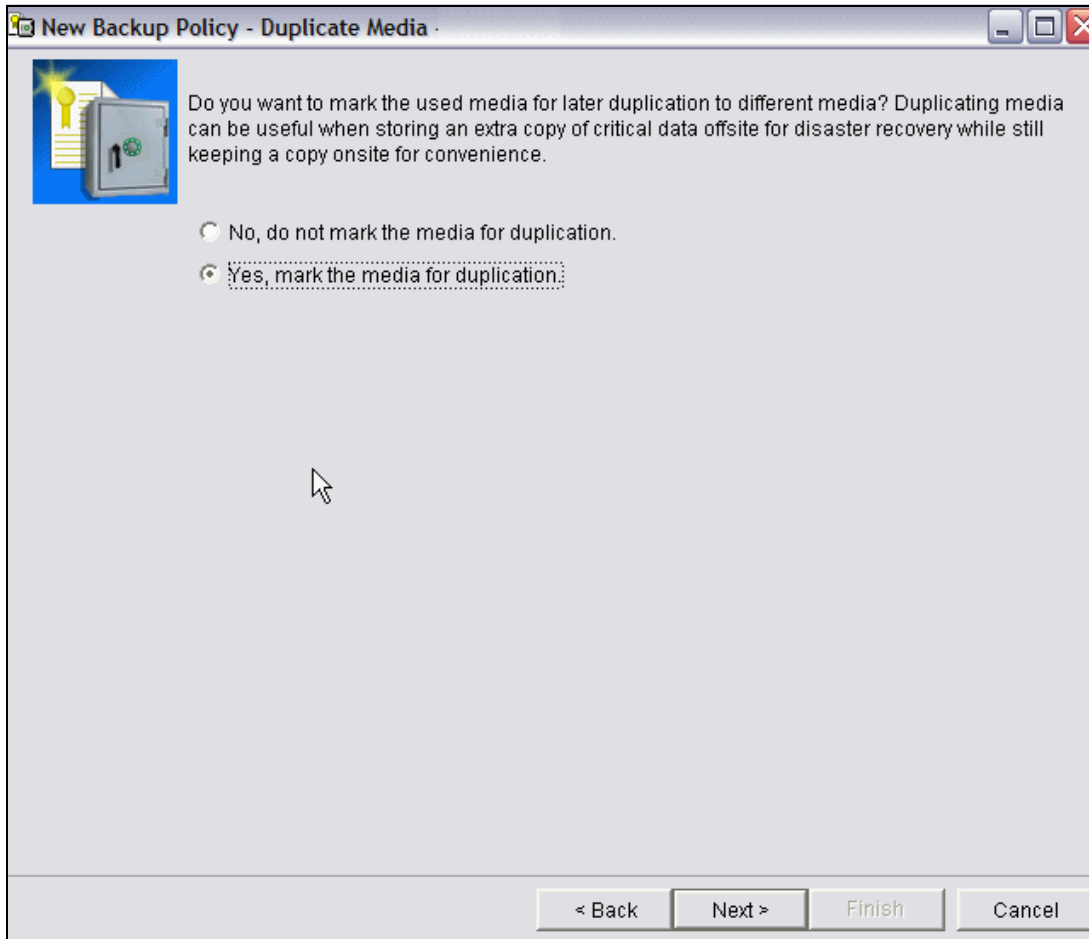

Figure 7-27 Duplicate media

4. When backup is done, since BRMS maintenance is not going to be run and will be a separate task in this scenario, select **No, do not run maintenance after save**, and click **Next**, as shown in Figure 7-28 on page 360.

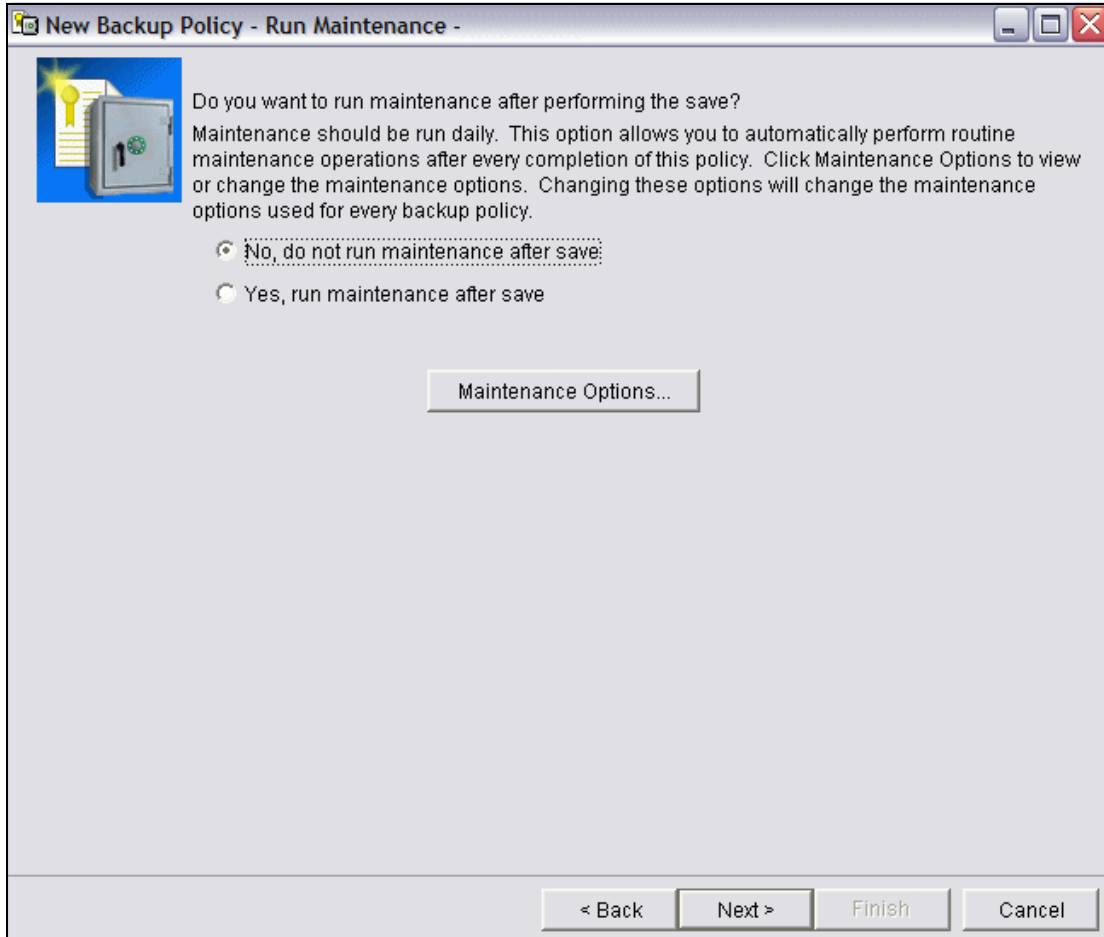

Figure 7-28 Run maintenance

5. The window shown in Figure 7-30 on page 362 allows you to add media. This can, alternatively, be done as a separate task.  
(To add media now, they should already exist. Otherwise you will receive the error message panel shown in Figure 7-29 on page 361.)

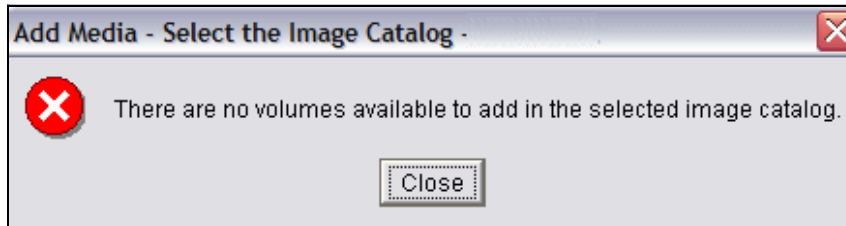

Figure 7-29 BRMS Add media, select image catalog error

**Important:** When backing out, be aware that if you cancel the whole task, all previous work will be lost.

6. At this point, since volumes are not being added, click **Next**, as shown in Figure 7-30 on page 362.

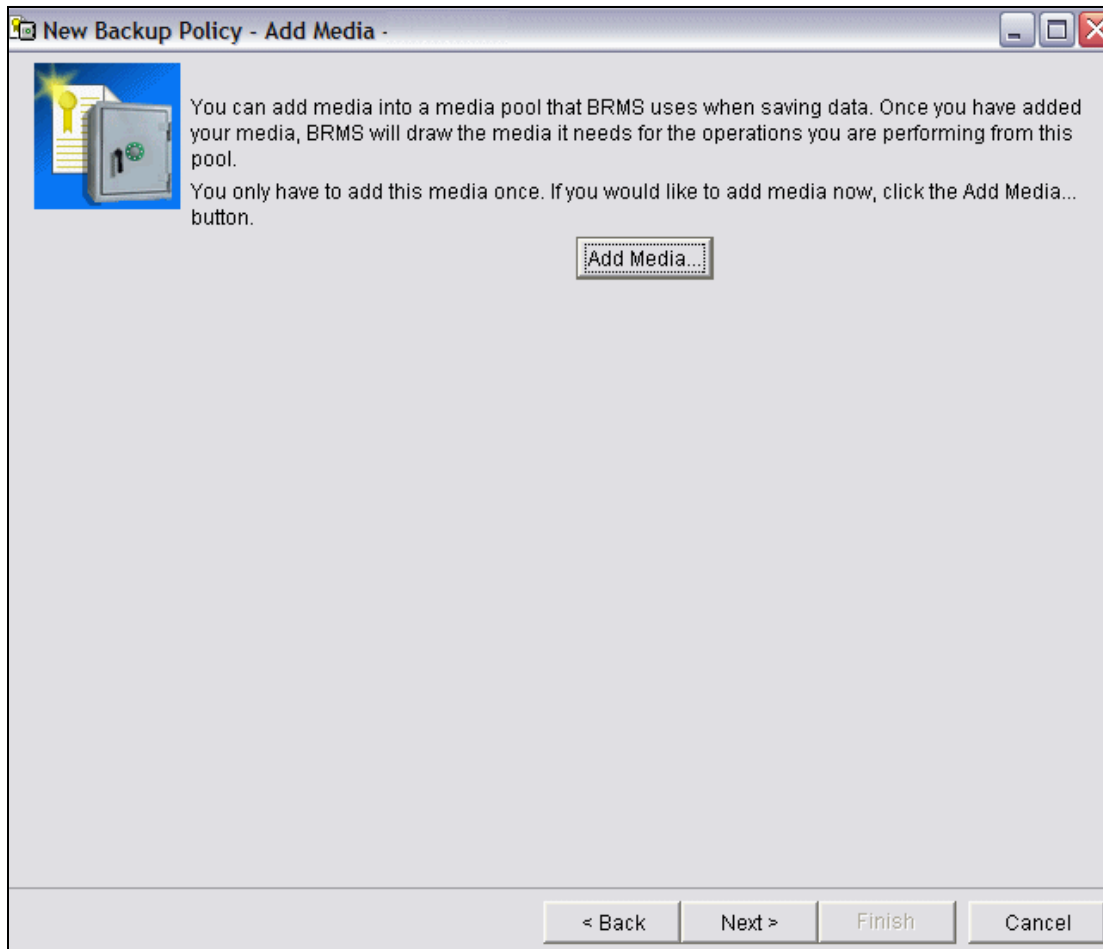

Figure 7-30 Add media

Before finishing, the create backup policy process shows a summary window (Figure 7-31 on page 363) displaying an overview of everything that you selected. If something is incorrect, click **Back** and select something else.

In this scenario everything is complete, so click **Finish**.

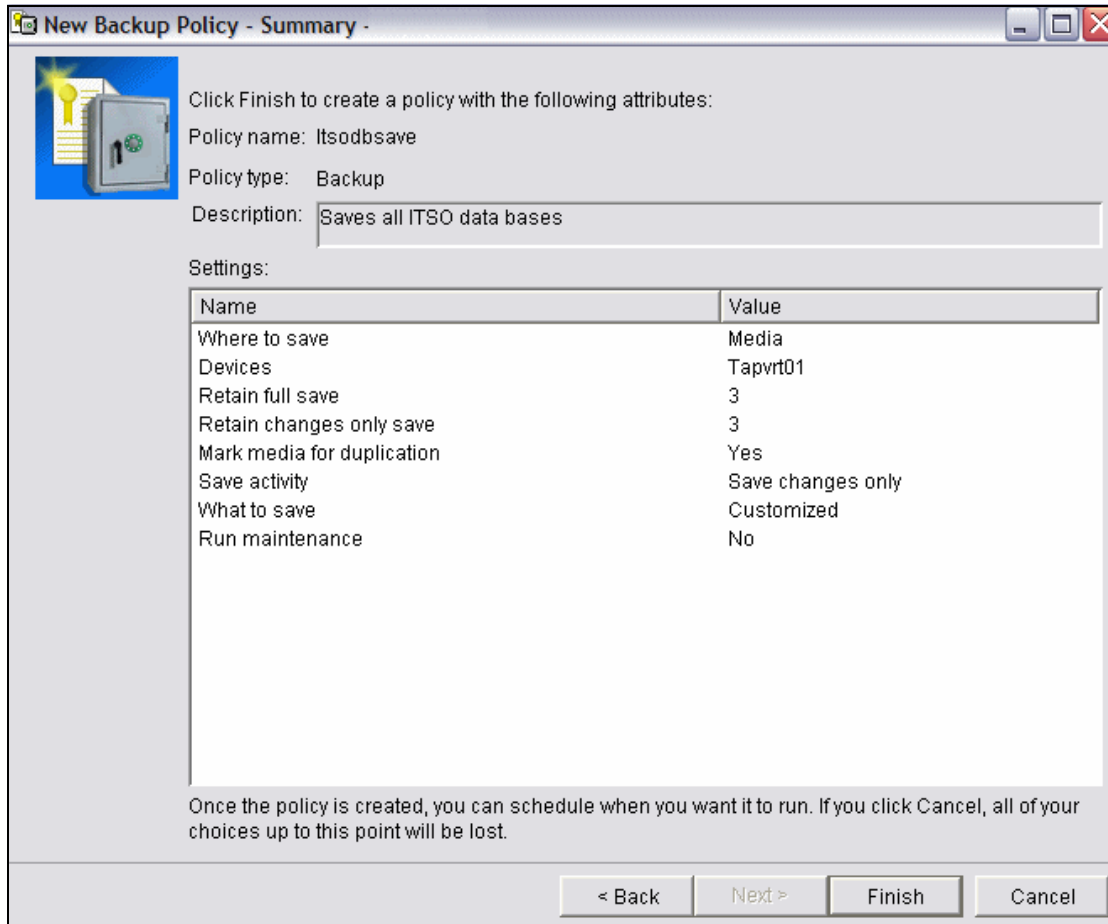

Figure 7-31 Summary screen - new backup policy

At this point, the backup policy is created.

7. A window appears, asking whether you want to run the backup policy right away or schedule it.

In this scenario, since there are other things to set up, click **Done**, as shown in Figure 7-32 on page 364.

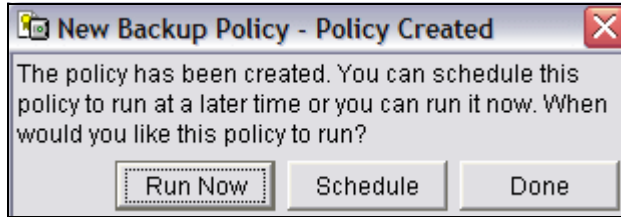

Figure 7-32 Policy created

8. To see the newly created backup policy, press F5 on the keyboard. This shows Figure 7-33.

Policy	Description
*Bkugrp	Backs up all user data
*Sysgrp	Backs up all system data
*System	Backs up the entire system
Aktest	CTLG for Albert Karels Residency Virtual Tape
Itsodsave	Saves all ITSO data bases

Figure 7-33 Policy list

This concludes the setting up of a tailored backup policy.

The next section describes the processes involved in tailoring a backup policy to behave the way you want it to. In a multi-tasking environment, you are not the only player. There are many requirements to consider before allocating objects.

## 7.4 Tailoring a backup policy to specific requirements

To tailor the backup policy, bring it up again by selecting it from the list of Backup Policies, right-clicking it, and selecting **Properties**. This displays a window similar to the one shown in Figure 7-34 on page 365.

When running a backup, there are terms and conditions that should be taken in consideration. They appear within the three buttons shown in Figure 7-34 on page 365:

- ▶ Before
- ▶ During
- ▶ After

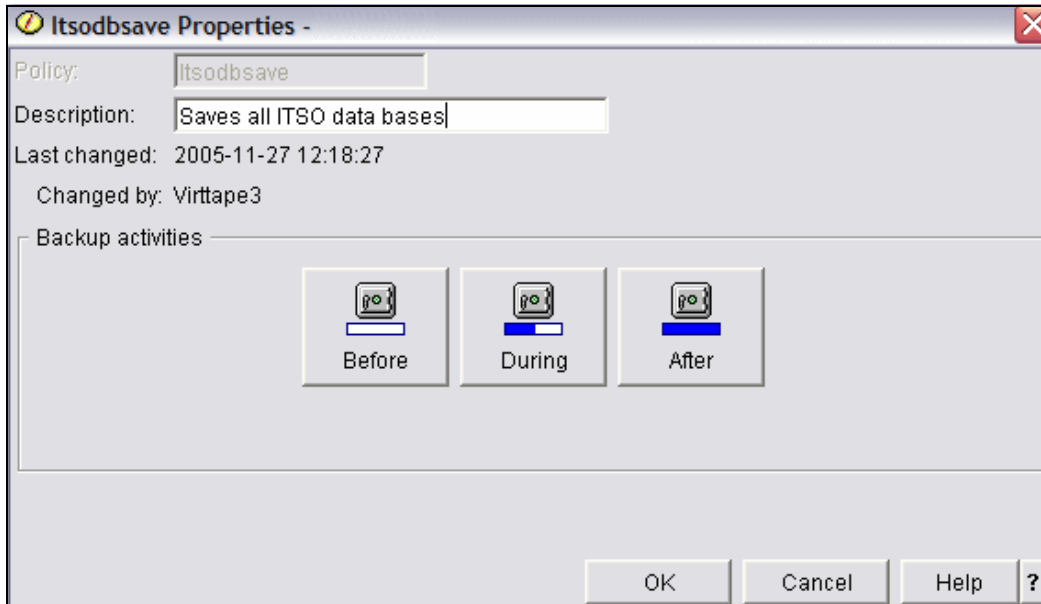

Figure 7-34 Properties

## 7.4.1 The Before activities

Prior to selecting Before in the Properties window, consider the following items before actually starting to save data. The Before section has three tabs:

- ▶ General
- ▶ Job queues
- ▶ Subsystems

### The General tab

Because this backup policy saves only i5 databases, under the General tab, deselect options for taking down file servers, and so on. By default, the check boxes for all the days are tagged, as shown in Figure 7-35 on page 366.

However, you can tailor it to your needs. Your decision about whether you have to throw out your active users is application-dependent. In our scenario, since the databases are not sensitive in that respect, we let them stay online.

You can specify the days on which you allow your backup to run. You can control this with the help of the job scheduler. Click the **Before** button as shown in Figure 7-34.

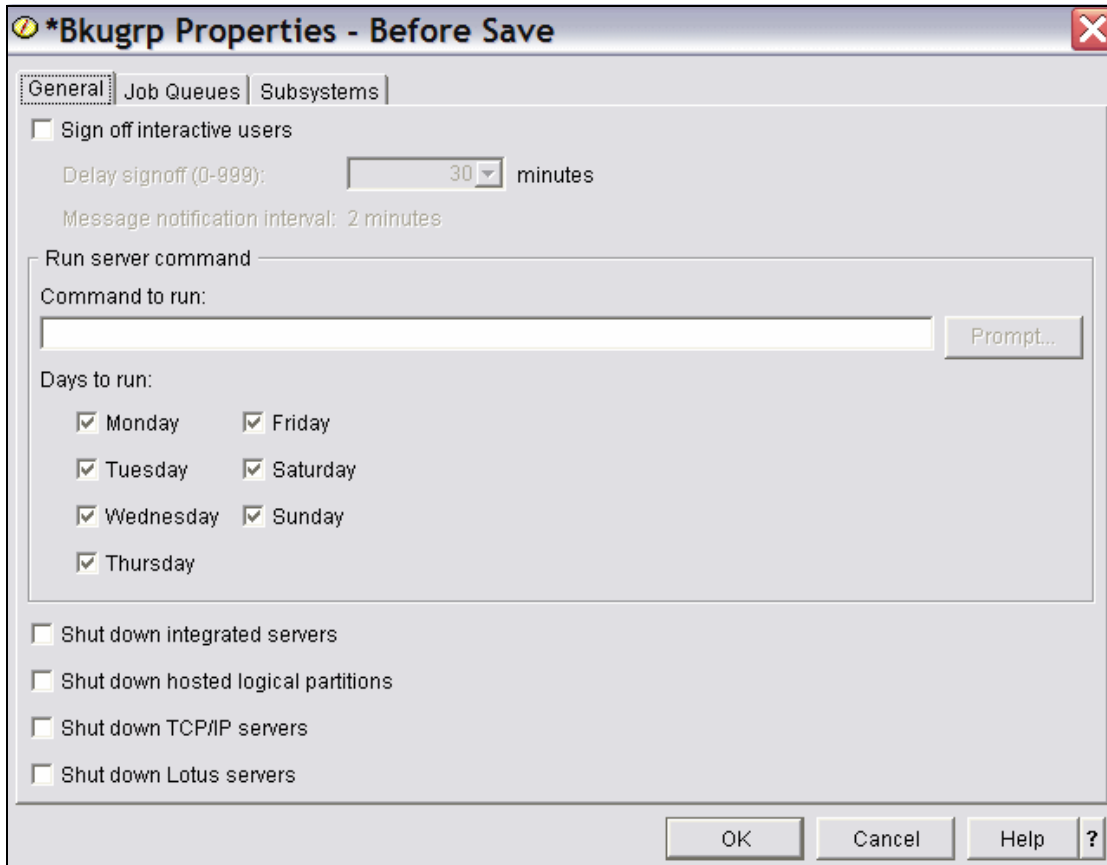

Figure 7-35 General tab

### The Job Queues tab

Under Job queues, specify which queues to stop before the backup starts. In this scenario, since there is no such requirement, nothing was specified, as shown in Figure 7-36 on page 367.

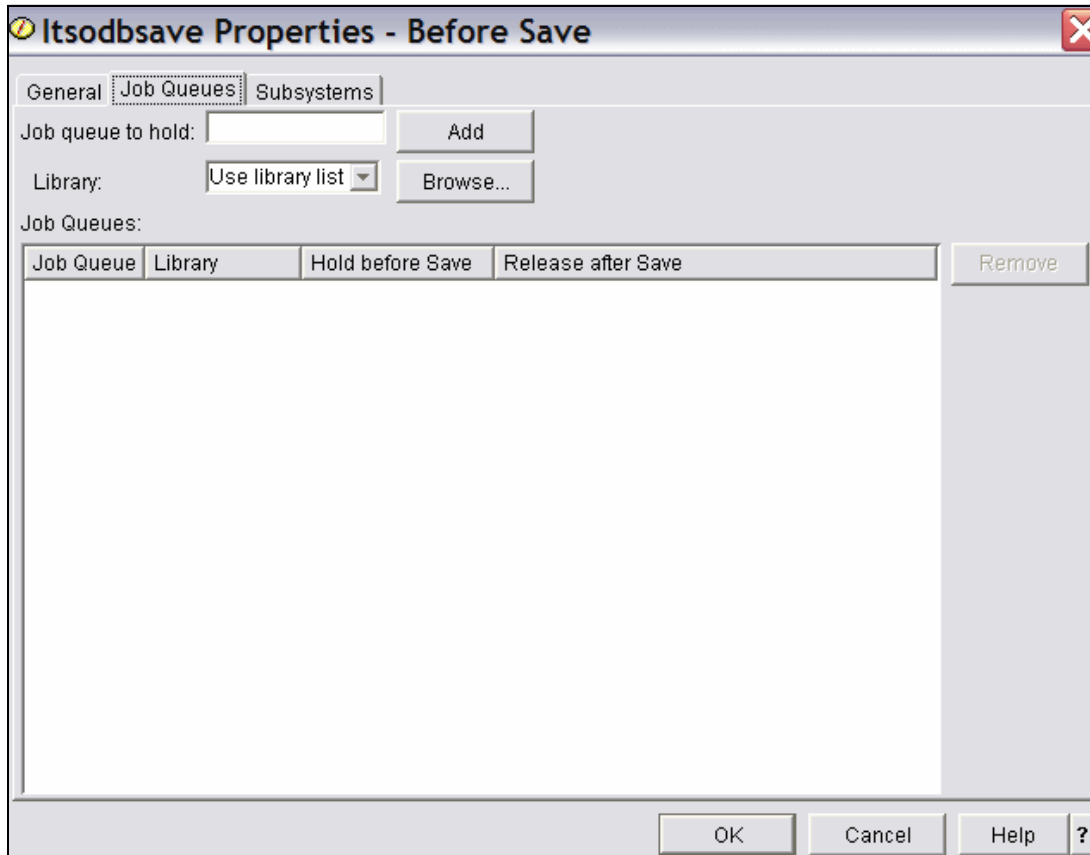

Figure 7-36 Job queues

### The Subsystems tab

Similarly, under Subsystems, you can stop any subsystem. In this scenario, since there is no requirement for any subsystem to be taken down during the backup, they are left as they are, as shown in Figure 7-37 on page 368.

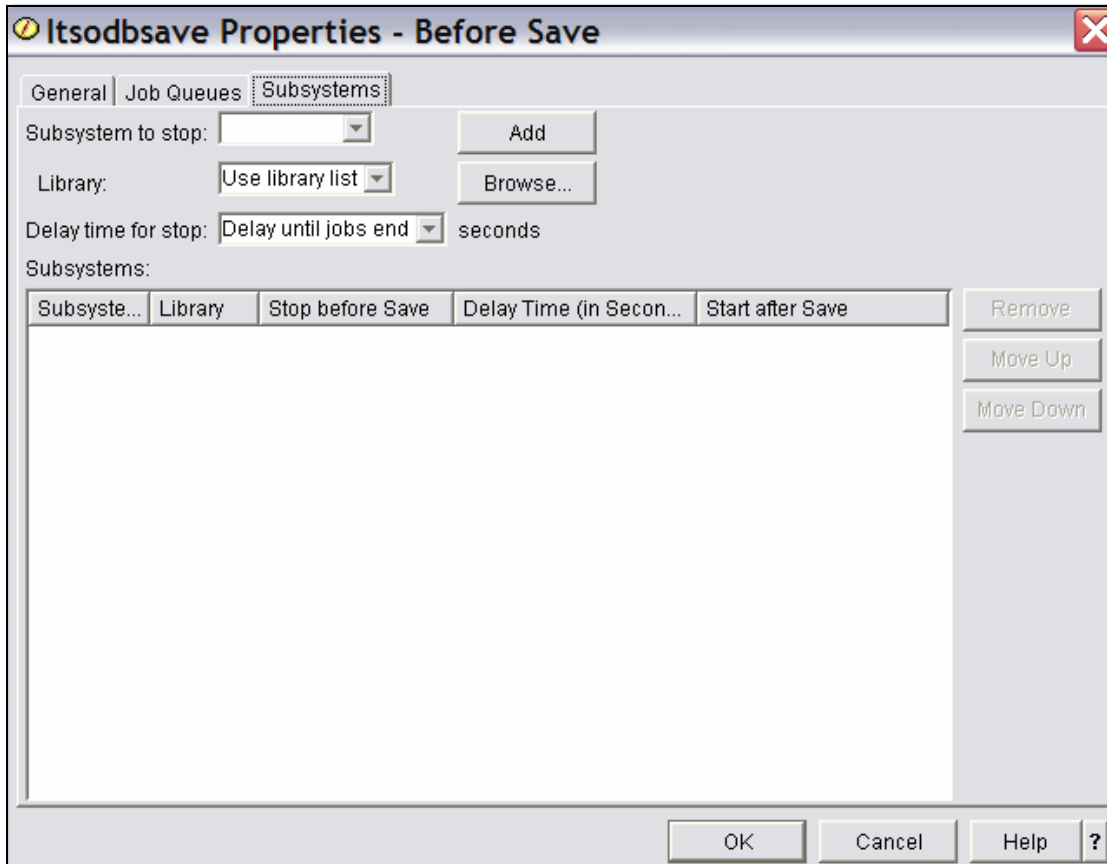

Figure 7-37 Subsystems

Since all the activities are complete, click **OK**. This takes you back to the Properties panel, shown in Figure 7-38 on page 369.

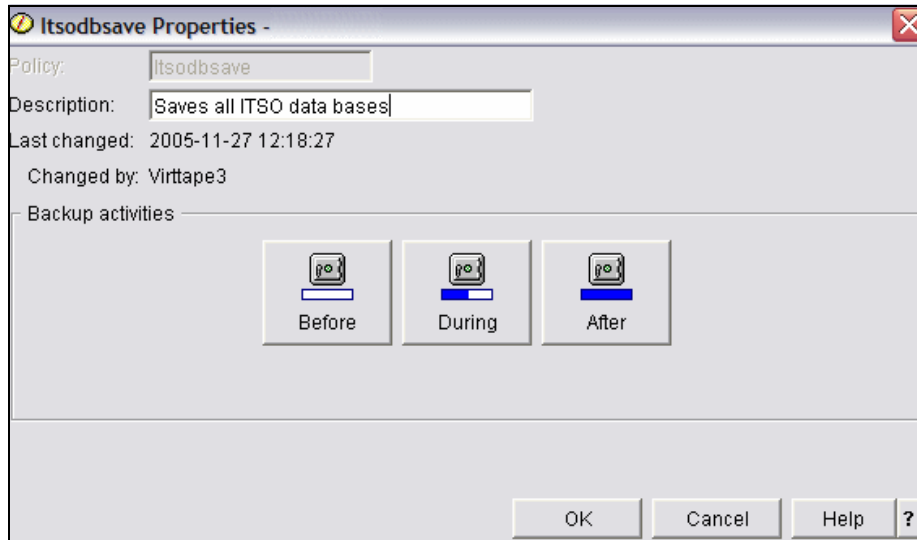

Figure 7-38 Properties

## 7.4.2 The During activities

When you select **During** in the Properties window, a window with five tabs appears, as shown in Figure 7-39 on page 371. We briefly explain these tabs here:

- ▶ What - what to save
- ▶ Where - where to save it
- ▶ Media Retention - how long to keep your backup
- ▶ Save File Retention - save to save files
- ▶ Activity - perform full backups, or changes only

Most of this has already been specified. However, there are a few points to be considered, including how much detailed information is needed.

### The What tab

Normally, you should specify that you want the BRMS inventory files saved to tape. You should also specify the amount of information you want to keep, that is, every detail or just at the library level.

In the case of virtual volumes, you may debate if there is any meaning in writing media information to such volumes. As long as BRMS is running, its online databases are used. If you save BRMS inventory files to virtual volumes, the physical tapes will, in fact, hold two inventory sets at the end.

However, when virtual volumes are duplicated to real volumes, you should make sure that these inventory files are added at the end of the physical tape. These files will, at that point, also contain pointers to the output tapes, and not just to the original virtual volumes. Pointing to virtual volumes only makes sense as long as the virtual volumes are active. Once overwritten, they are gone.

Therefore, saving this type of information to a virtual tape only adds time to the backup and wastes disk space. However, by doing so, you stand a risk of not having the latest media information saved until you have copied your virtual volumes to physical tapes.

**Note:** If you do not save BRMS media information (= inventory information discussed earlier), and for whatever reason the system crashes beyond hope of recovery, the inventory files contain information about all the backups.

If you do not duplicate your virtual volumes to physical media, you should at least copy BRMS media information to a real tape on a daily basis and store it in a safe place so that you can get these important files back. They are vital for system recovery.

To get the data back, especially if you save to TSM, BRMS inventory is the only place in which you will find the keys to your data in the Tivoli® server.

Following are the options for what to save:

- ▶ All
  - All object details are kept in the backup history down to member level.
  - When storing folders, this is the only option that is available.
- ▶ None
  - No object detail is kept in the backup history.
  - You will only be able to get online assistance with restore at the library level.
  - In case you restore a single object, you should know its name.
- ▶ Errors
  - Only information about errors is kept in the backup history.
- ▶ Objects
  - Only information about objects is kept in the backup history.
  - Information about members is not kept.

The best course of action is to save everything. There is, however, a downside to this. The more information you collect, combined with the longer you keep that information, the bigger the inventory files will be.

In this scenario, because the example backup is small, no such problem exists. Therefore, we want to see what we have backed up in detail, but not as deep as going to the object member level. Proceed as follows:

1. Click the **What** tab. Under the column Track Object Detail, select **Objects**, as shown in Figure 7-39.

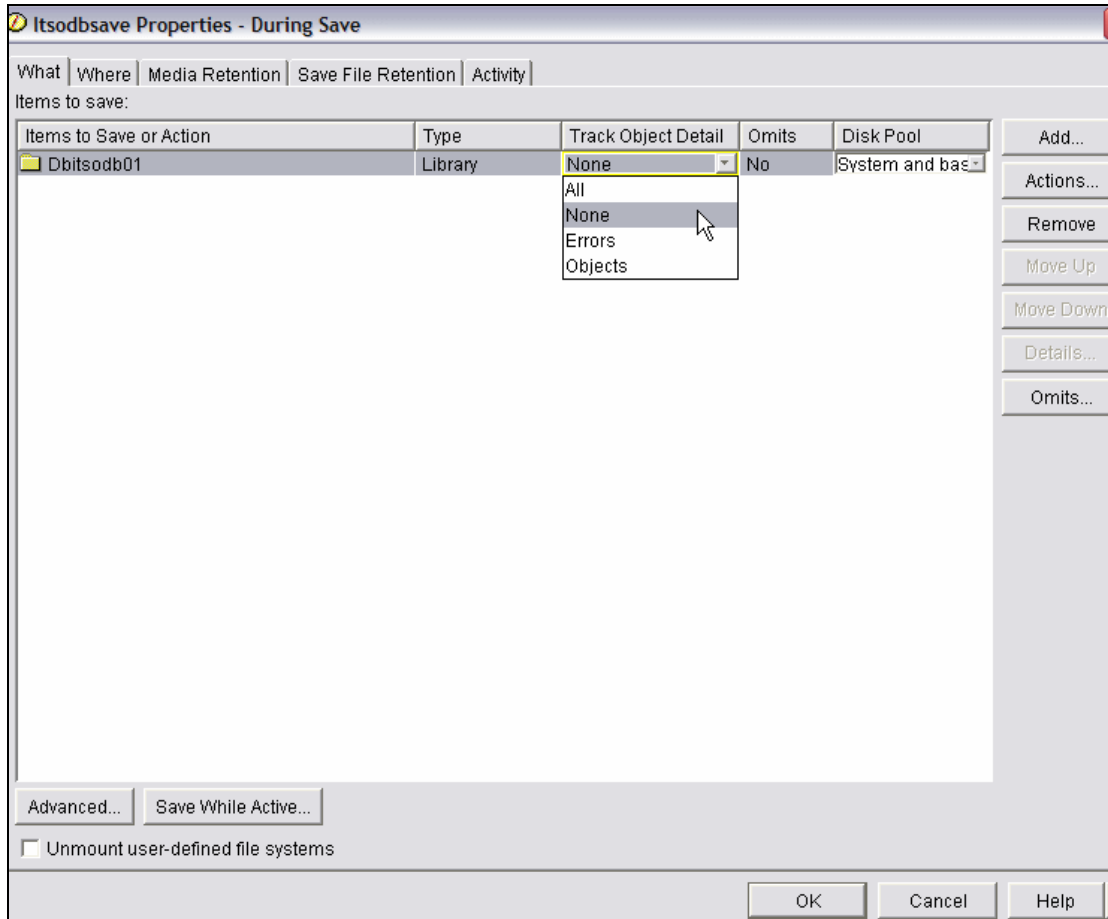

Figure 7-39 What to save

2. Click **Advanced** under the What tab.

Before clicking **Advanced**, however, you should understand how BRMS acts when saving the data if journaling is involved. The i5 operating system has journaling built in. Journaling is aimed up to the last transaction recovery.

BRMS tries to minimize the backup run time and keep any downtime as brief as possible. When saving changes only, if BRMS detects that files are

journalled, it will not back up the actual file, but only the journal transactions or journal receivers. This is brilliant, but it has a downside. It makes things complicated, when the idea is to keep the recovery as simple as possible.

If you do not select Save journal objects when changing saved objects, keep in mind the following:

- Files that are not journalled are restored normally with all their content.
- For files that are journalled, BRMS restores the latest full backup. You should then add the transactions from the journal receivers using the APYJRNCHGX command.

3. Select **Save journal objects when saving changed objects**, in the window shown in Figure 7-40 on page 373.

If files are journalled, and you can access their journal and journal receivers, you can recover these files up to the last transaction. This helps you have the best of both worlds. You have an easy recovery using BRMS (assuming you select **Save journal objects when changing saved objects**), and you can take the restore task a step forward and recover all the journalled files up their last transaction.

Before trying this, however, contact the application provider so that you do not end up with unbalanced data, where some files are recovered up to the last transaction and some are recovered from the last backup.

4. Select **Save contents of save files**, if you have such files.
5. You can also specify whether restore will be done on a system with a different release. However, in this scenario, since such a requirement is not there, leave it at default. Click **OK**.

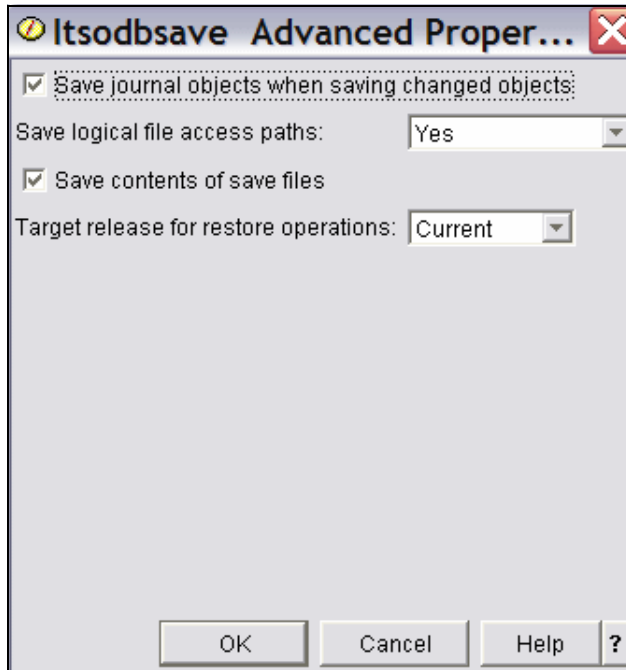

Figure 7-40 What to save - Advanced

### The Where tab

1. Click the **Where** tab. A window similar to the one shown in Figure 7-41 on page 374 appears.

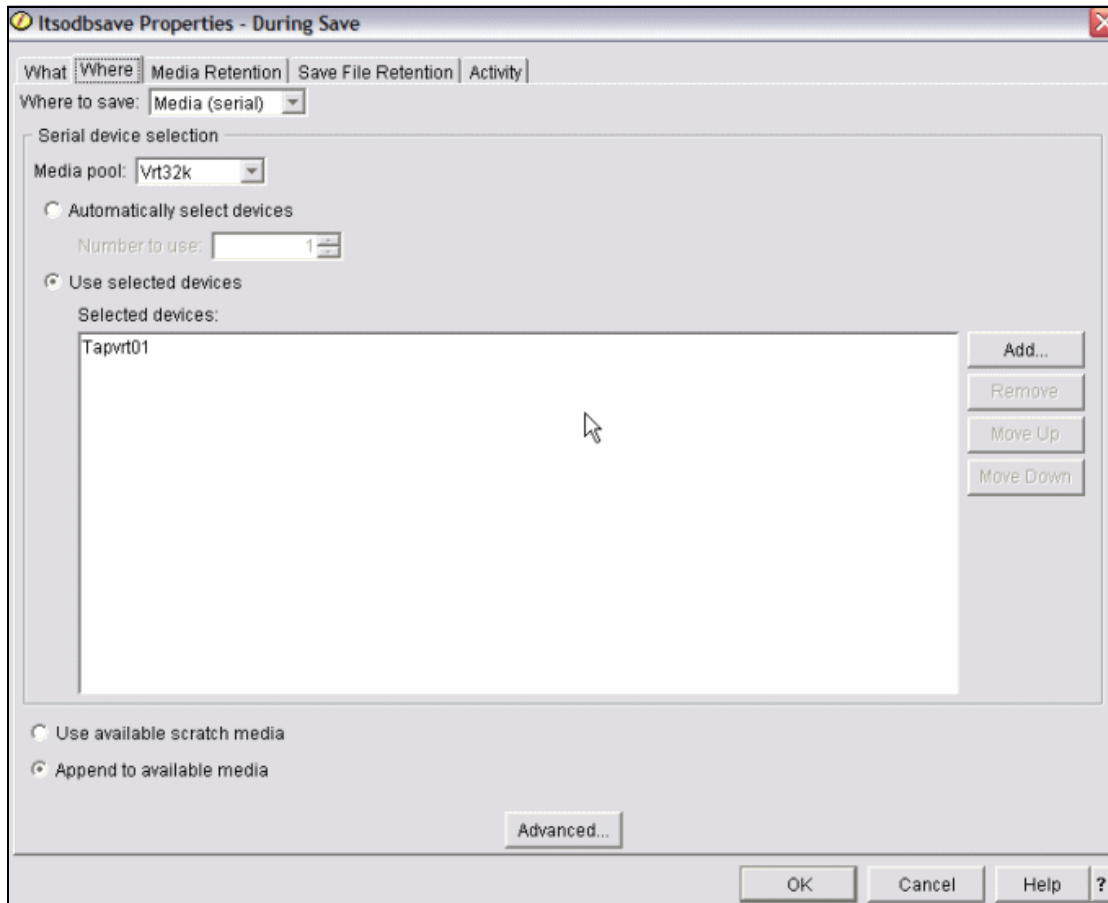

Figure 7-41 Where to save

Specify whether you will take new volumes for each save, or put the backups at the end of a volume already containing active data. (You need to decide what is best for your environment.)

2. Click **Advanced**. The window shown in Figure 7-42 on page 375 appears. Here you specify how duplication of the virtual volumes to real tapes should be done.

In a virtual environment, you will probably take new volumes for every backup, so the first option of duplicating the complete volume is the natural choice. That does not mean you need new volumes for the copy. For real tapes, you can add backups one after another on the same physical tape, if you prefer it that way.

3. After making your selections, click **OK**, as shown in Figure 7-42 on page 375.

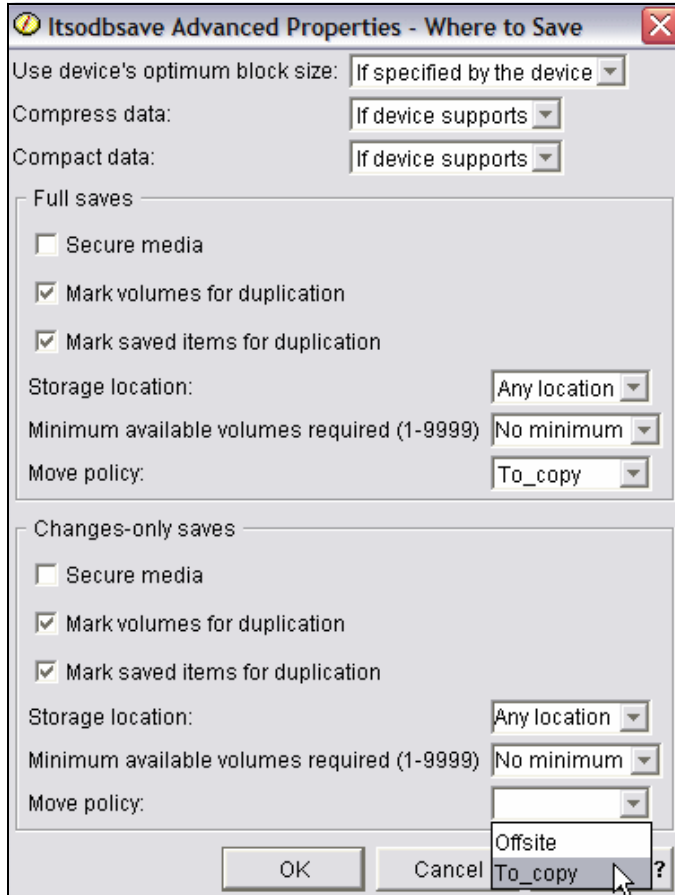

Figure 7-42 Advanced properties

All the other tabs (Media Retention, Save File Retention, Activity) in the During Save window shown in Figure 7-41 on page 374 are only a summary of what has been specified. Therefore, you can leave them unchanged.

4. Click **OK** in Figure 7-41 on page 374 to return to the Properties window shown in Figure 7-43 on page 376.

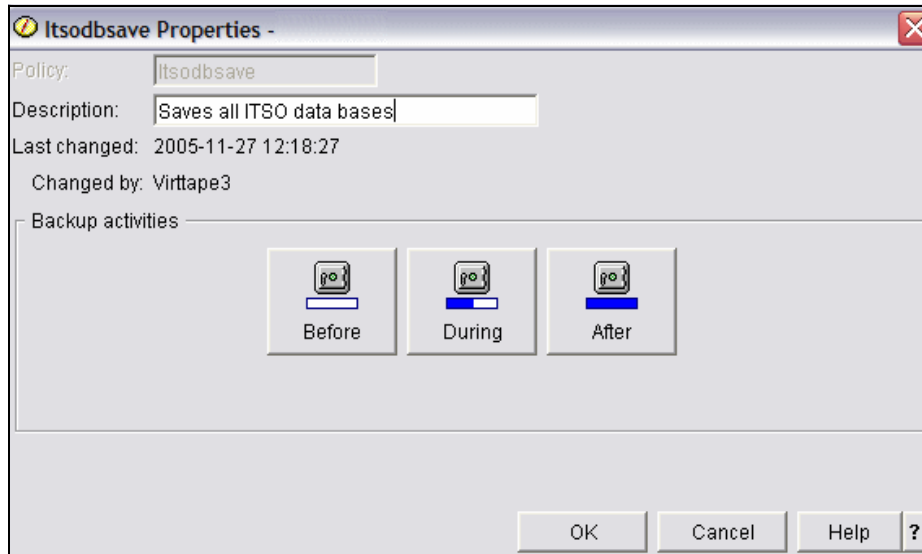

Figure 7-43 Properties window

### 7.4.3 The After activities

The After tasks are essentially the opposite of the Before activities.

#### The General tab

In the Before window, everything dealing with taking down servers was deselected. Therefore, there was no requirement to start them after the backup is finished.

Click **After** in the Properties window; the window shown in Figure 7-44 on page 377 is displayed.

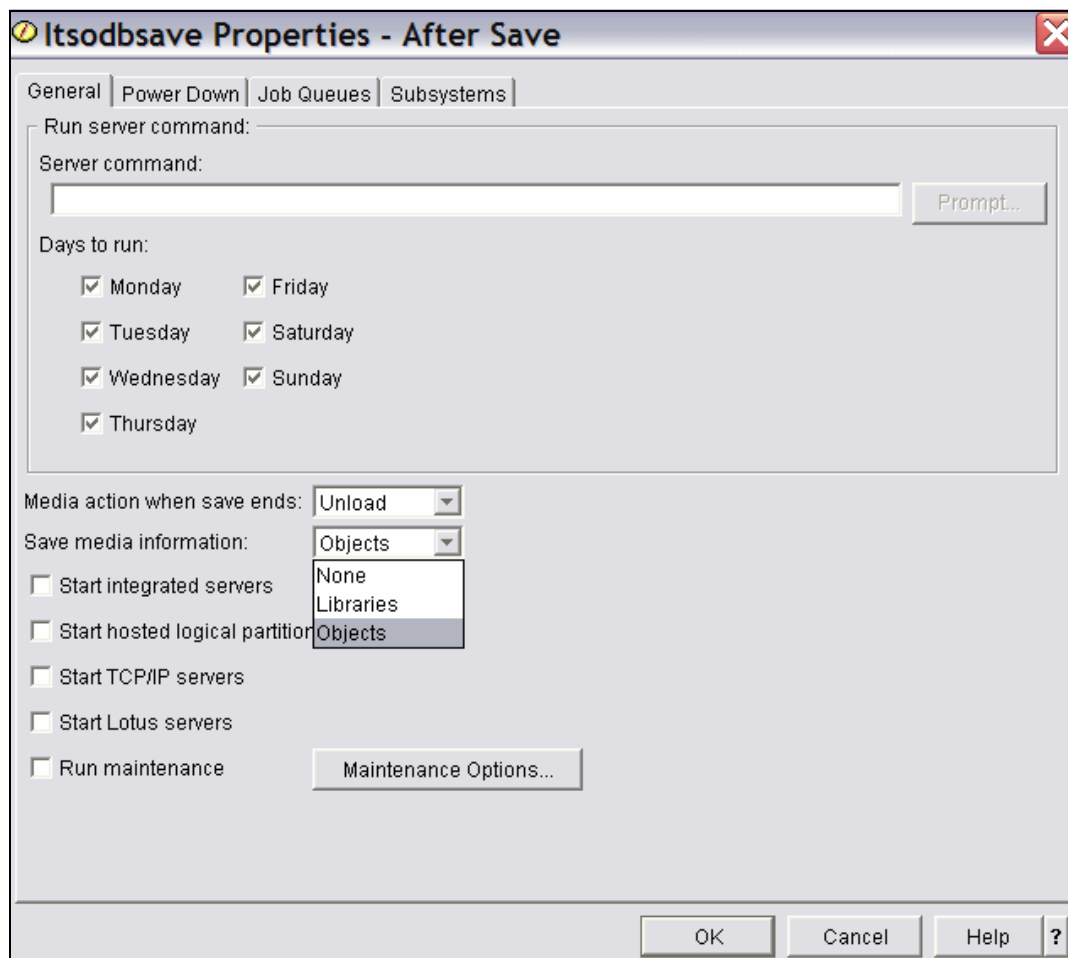

Figure 7-44 General tab

### The Power Down tab

Use Power Down if you want to restart your system after the backup is completed. In this scenario, it is left untouched.

Return to the Properties page by clicking **OK**. This takes you back to the Backup Policy Properties page. Since there is nothing more to specify, click **OK**, as shown in Figure 7-45 on page 378.

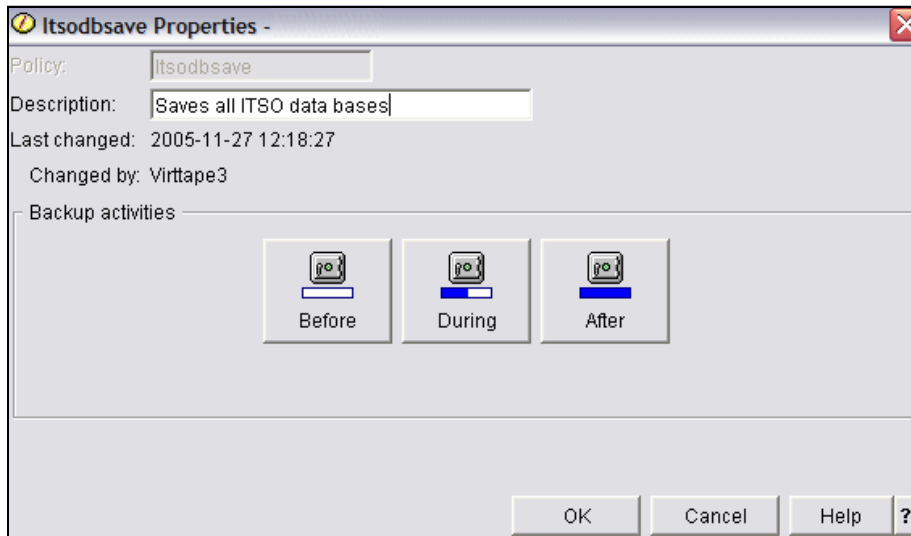

Figure 7-45 BRMS backup policy, properties - done

Before execution, verify that you have virtual tape volumes relating to the selected density \*VRT32K. They should exist in the image catalog, since you are pointing to it. It is much more convenient to have all your volumes in a common image catalog.

This concludes the section on tailoring the backup policy.

## 7.5 Adding media to BRMS

Adding media to BRMS is a logical add only. No tape volumes are created. When adding physical tape volumes, just provide names and they will be added. You can add them in advance.

However, this is not the case for virtual volumes. They have to exist.

You can add media “on the fly” as well, while creating a backup policy. To make things simple, you can treat it as a separate task, and perform the following actions:

1. Right-click **Tape Volumes** and select **Add**, as shown in Figure 7-46.

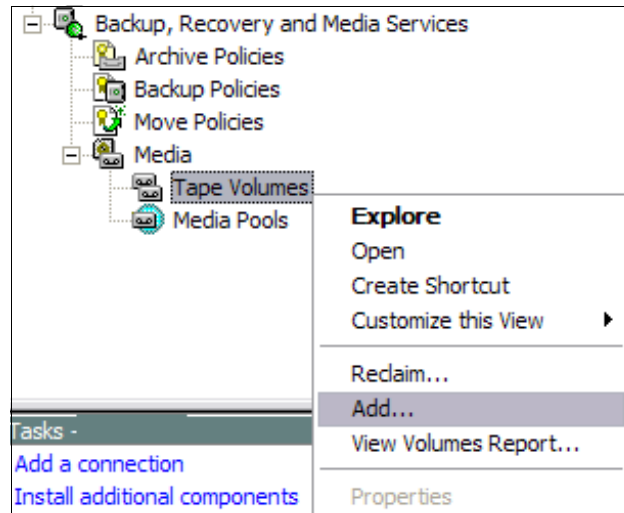

Figure 7-46 BRMS adding media

2. In the Welcome window that appears, click **Next**.
3. In the Select Media Pool page that appears, select the media pool (in this case, **Vrt32k**) as shown in Figure 7-47 on page 380.

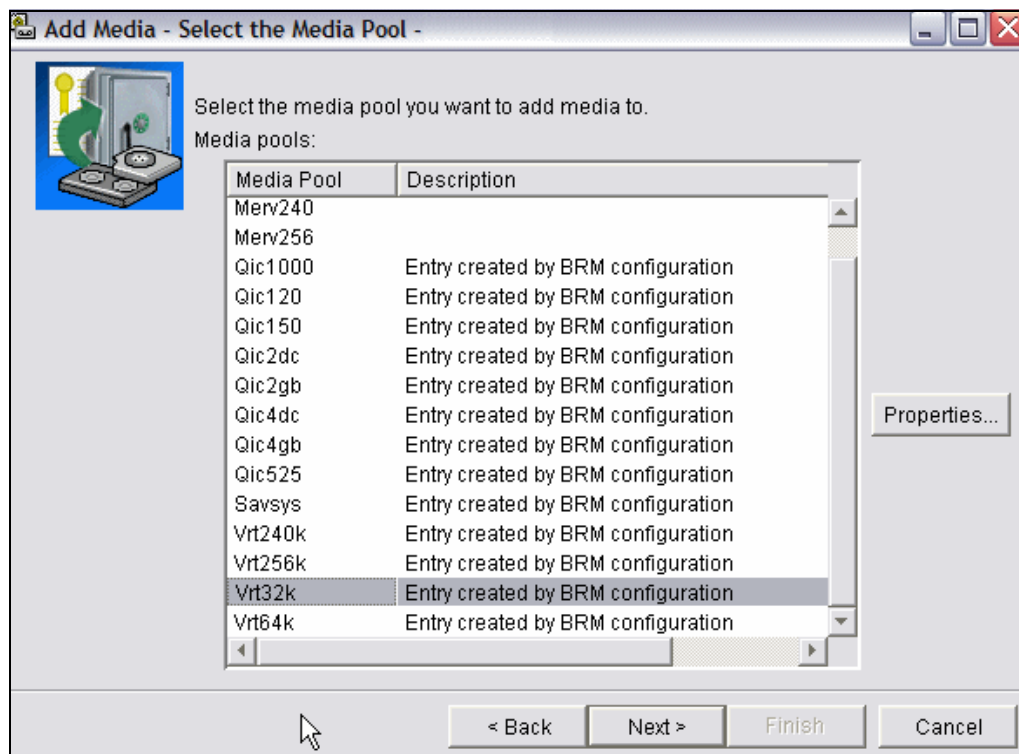

Figure 7-47 BRMS adding media, media pools

By clicking Properties, you can make changes to a media pool (for example, specifying a more understandable text). You can also change the amount of megabytes that the resulting virtual tape volumes will store.

In this scenario, since the backup is not very large and disk space should not be wasted on allocating empty areas, they were set to 5000 MB (5 GB), as shown in Figure 7-48 on page 381. When this is full, BRMS will automatically find a new volume the operating system places the data in.

**Note:** It is the operating system that executes a backup. BRMS only supplies the terms and condition and stores the result when the backup is finished.

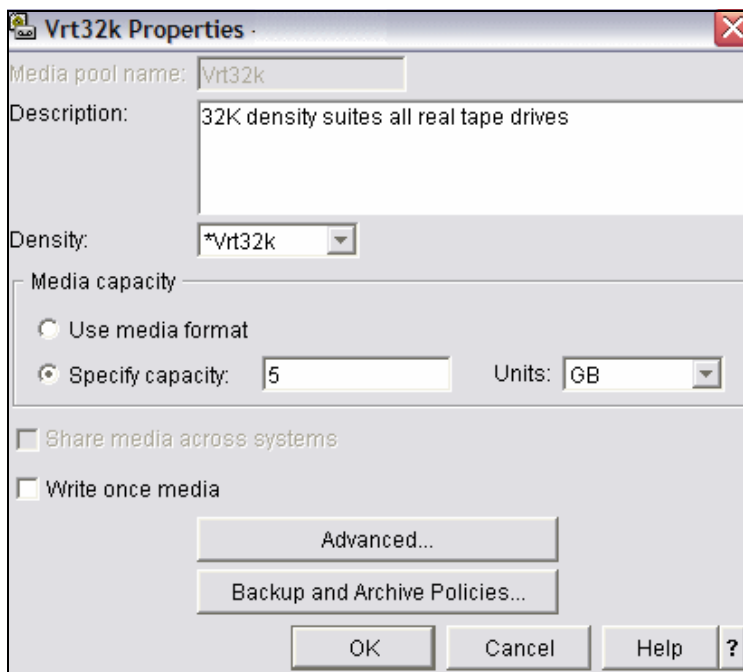

Figure 7-48 BRMS adding media, media pools - properties

The Advanced option in the Properties window shown in Figure 7-48 relates only to physical media, while the Backup and Archive policies option helps you specify whether you want to allow full saves, changes only, or both.

In the Advanced window, you can also indicate if you want to share media across systems. This is normal when several systems back up to a common tape library.

In this scenario, since we are saving to virtual tapes that are created under an image catalog somewhere on an ASP (which makes it a bit complicated to share volumes), this option is left unselected. The same is the case with Write once media, since it applies only to optical media.

To leave the Advanced window, click **OK**.

4. In the Select media pool window shown in Figure 7-47 on page 380, since pool V32K is already selected, click **Next**.
5. Specify where to find the volumes that are going to be added to BRMS. All virtual volumes are created in image catalogs. BRMS presents you with all the image catalogs that it is aware of at this point, as shown in Figure 7-49 on page 382. Select your image catalog **itsodb**, and click **Next**.

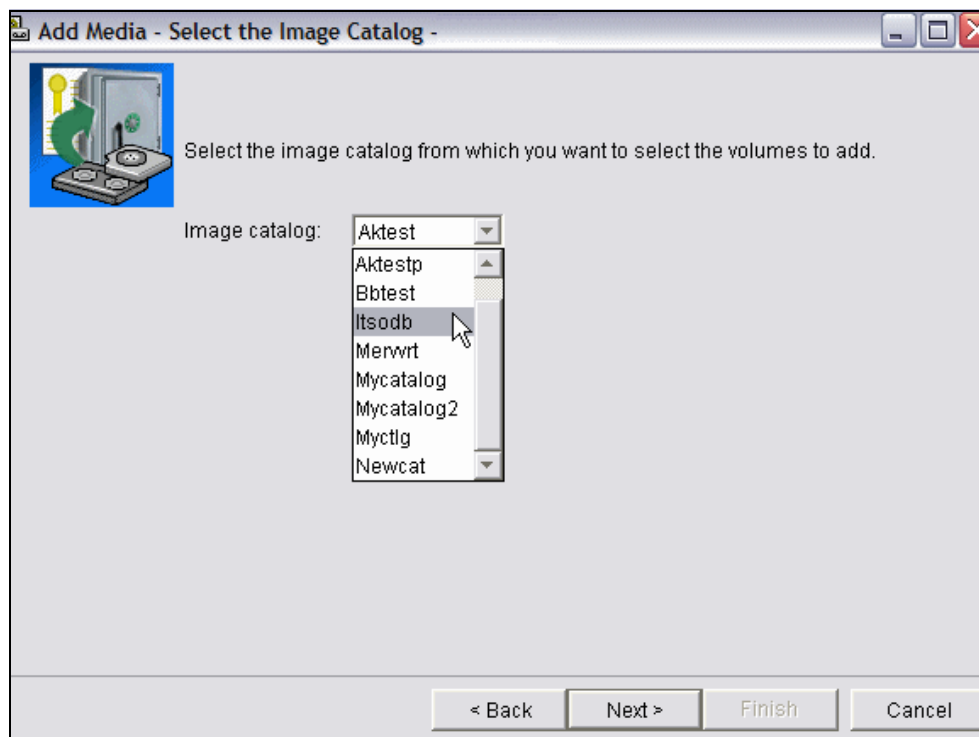

Figure 7-49 BRMS adding media, select media pool

6. A list of all volumes in the selected image catalog is presented.  
In this example, there are five volumes. Add all of them to BRMS by selecting them and clicking **Next**, as shown in Figure 7-50 on page 383.

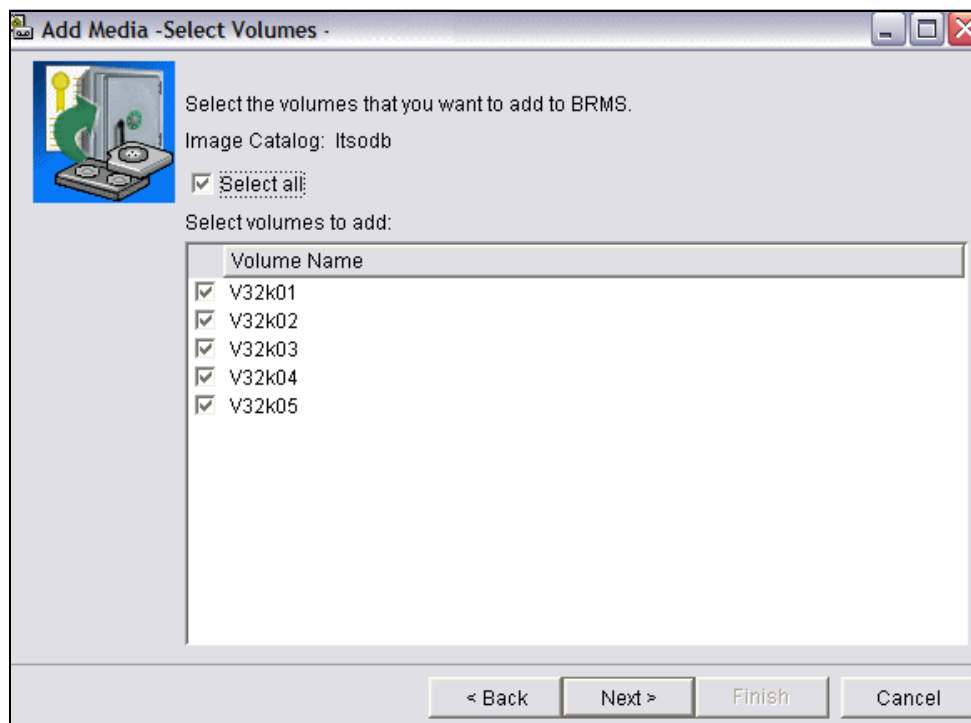

Figure 7-50 BRMS adding media, select volumes to add

Now decide on where to place your volumes, since BRMS presents all the existing locations. In this scenario's move policy, it is specified that the volumes should bounce between locations VIRTUAL and COPIED. Therefore, the obvious thing would be to have them in location VIRTUAL.

You can place them in any location. However, think of these virtual tapes as you would real tapes, that is:

- There should be a tape unit.
- The tape unit has to be varied on.
- The tape unit has to be ready.
- The tape unit has to have a tape mounted or at least loaded.
- The tape must be unlocked (write protect switch).
- The tape must be of correct density.
- The tape should be initialized.
- The tape must have a unique name.
- The tape must be expired unless you append to its end.
- You must have enough volumes to contain the data to be saved.
- BRMS must be aware of the tape units' existence and characteristics.

Make your choice with these points in mind.

7. Add virtual volumes to location VIRTUAL by using the drop-down menu against Location in the Select Media Storage Location window. Select location **Virtual**, and click **Next**, as shown Figure 7-51.

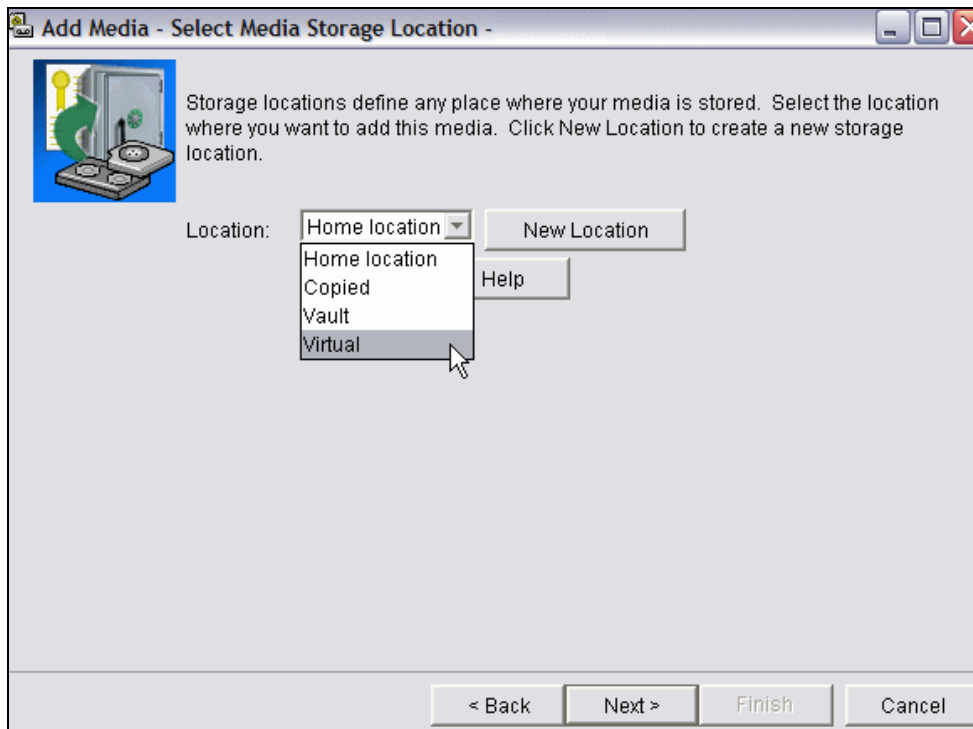

Figure 7-51 BRMS adding media, select location

8. The next window, shown in Figure 7-52 on page 385, allows you to initiate the media and virtual tape drive that should be used. Do so, if required.  
In this scenario, since it is assumed that they are already initiated, click **Next**.

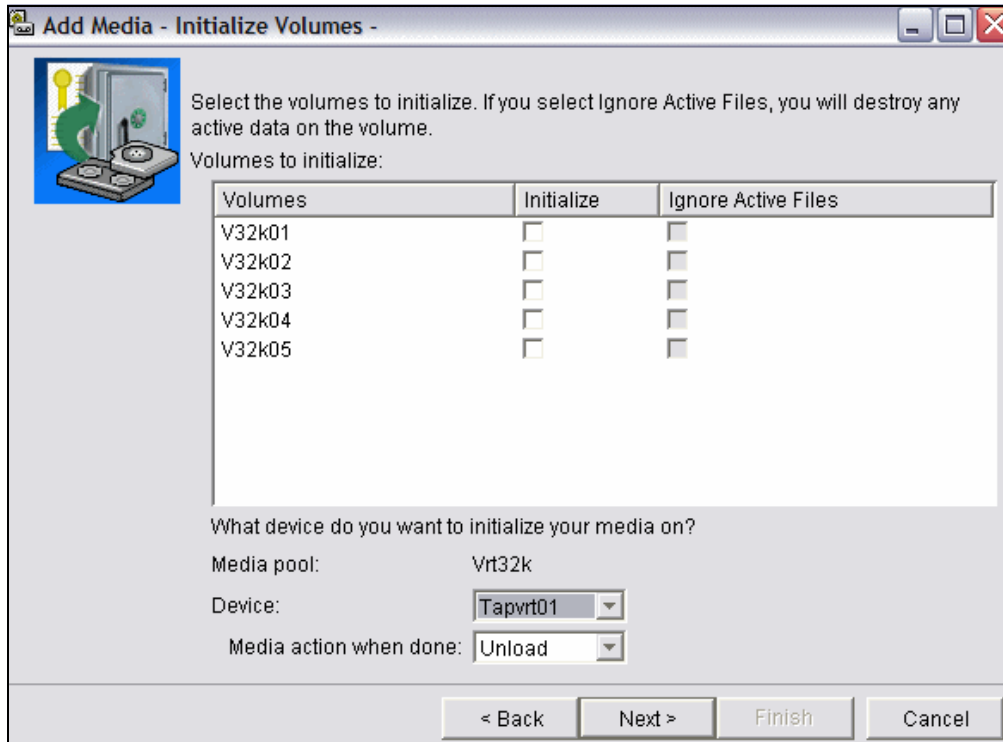

Figure 7-52 BRMS adding media, initialize tape volumes

9. The last window is a summary of the selections made. In this scenario, since you do not have to go back and change anything, click **Finish**.

This concludes the section on adding media to BRMS. You are now ready to execute your backup policy.

## 7.6 Running the backup

To execute the backup policy, perform the following tasks:

1. Look up **Backup, Recovery and Media Services** and ensure that everything is set to run the backup.

**Note:** We deliberately set it up so the example backup will not work. The backup, as defined, will work. However, we made sure that the virtual image environment is not in a ready state to accept the data, exactly as it would have been, had you forgotten to vary on the tape drive.

We thought it would be useful to show some of the pitfalls, rather than have you discover them by yourself. The examples are found in n Chapter 8, “Debugging examples using the GUI” on page 431.

2. Right-click **Backup, Recovery and Media Services** and right-click your policy (in our case, **Itsodbsave**). Then select **Run Now**, as shown in Figure 7-53.

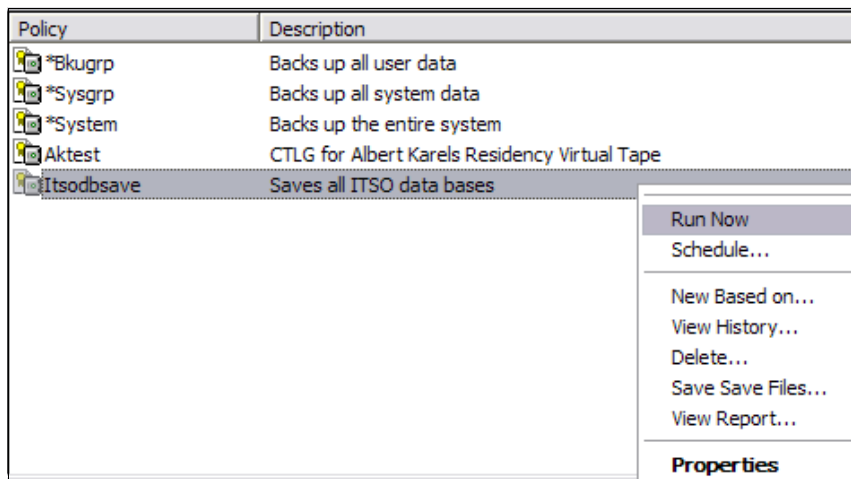

Figure 7-53 BRMS running the backup, Run Now selected

As an alternative, you can click the **Run** icon in the top left corner, as shown in Figure 7-54.

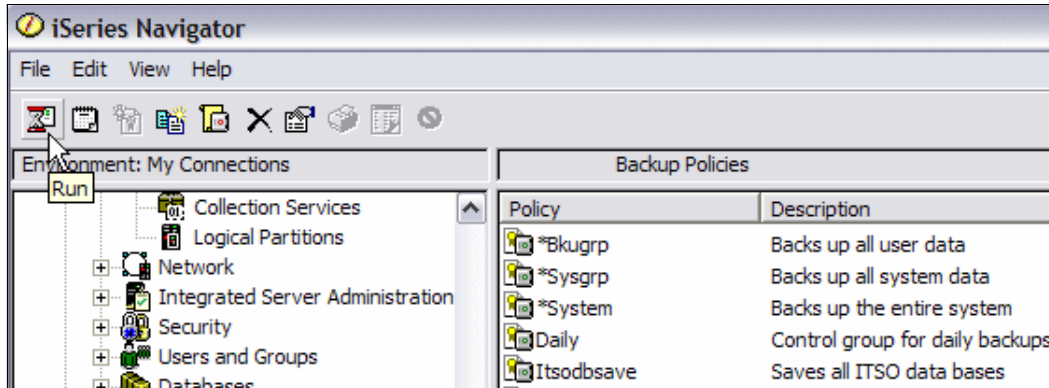

Figure 7-54 BRMS running the backup, run button

3. The window that appears, shown in Figure 7-55, asks if you want to perform any overrides.

Since this is not required in this scenario, click **OK**, as shown in Figure 7-55.

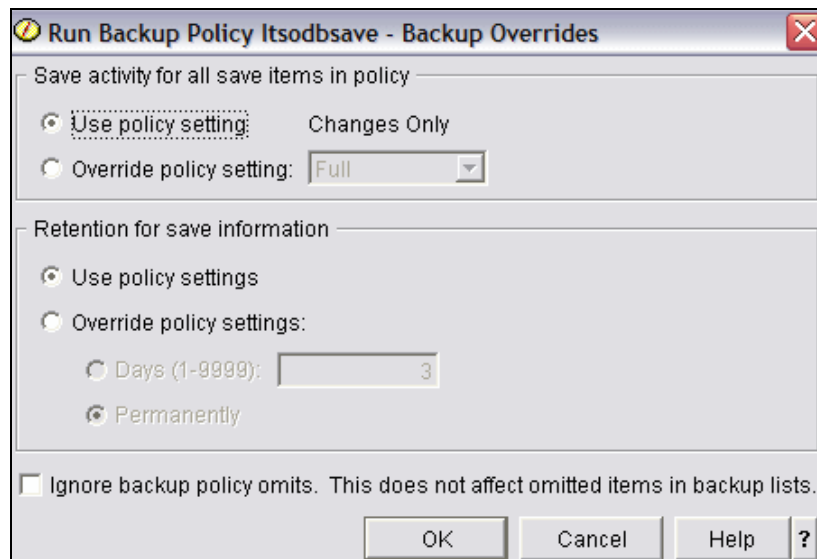

Figure 7-55 BRMS running the backup, overrides

To run the job, you should be connected to the central system. If you are not, you will be asked to (or the Navigator will try to connect you). This can take a while.

The Management Central servers in the endpoint or BRMS IBM @server iSeries server should also be running. They should start automatically when an iSeries is powered on.

The central system connects to the endpoint system to initiate the execution of a task (for example, BRMS backup, restore, maintenance, and so on). Wait for the connection to the central system to take place.

4. When this is done, specify whether you want the joblog or not. The first time you run the job, it is useful to view the joblog regardless of the end result, just to understand what the job did. Click **OK**, as shown in Figure 7-56.

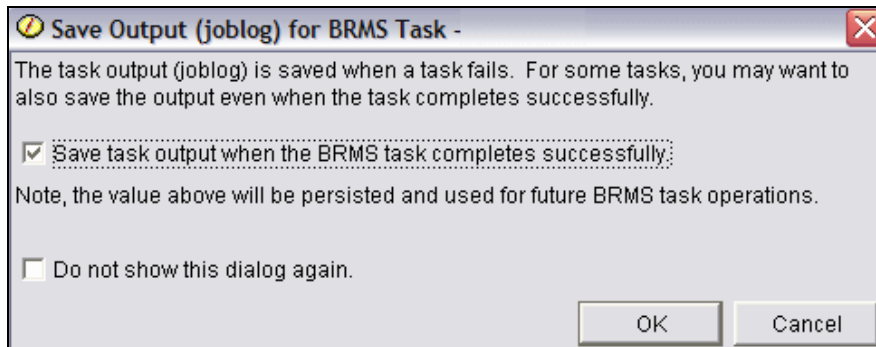

Figure 7-56 BRMS running the backup, save joblog

The Navigator status bar shows a message indicating what is going on, as shown in Figure 7-57.

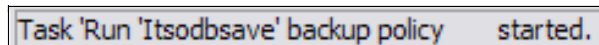

Figure 7-57 BRMS running the backup, started - indication on status bar

5. Pop-up windows such as the one shown in Figure 7-58 also appear. Click **OK**.

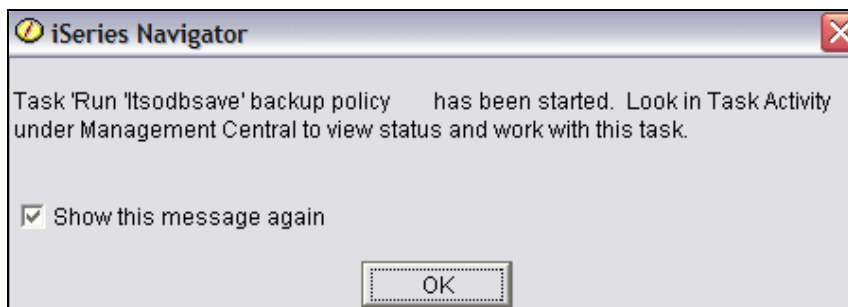

Figure 7-58 BRMS running the backup, backup policy started pop-up

A status pop-up window, shown in Figure 7-59, displays while the backup is executing.

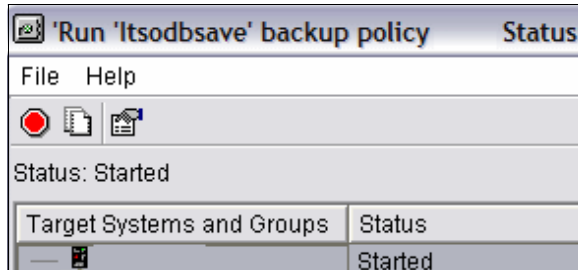

Figure 7-59 BRMS running the backup, status started

When finished, the status displayed changes to Completed, as shown in Figure 7-60.

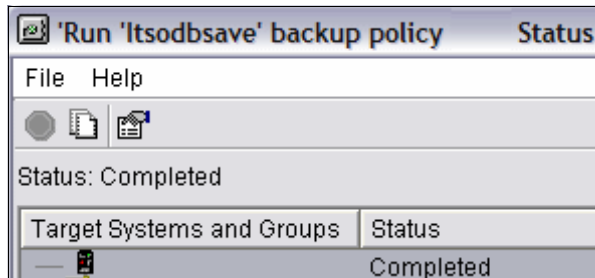

Figure 7-60 BRMS running the backup, status completed

This concludes the section on running the backup.

## 7.7 Restoring an object

Restoring objects is a simple task, and is done from Backup, Recovery and Media Services Tasks.

It is assumed that:

- ▶ The image catalog is in loaded status.
- ▶ The virtual volumes still exist.
- ▶ There is a tape unit that is varied on.
- ▶ The tape unit is ready.
- ▶ The tape unit should have the backup tape mounted or at least loaded.

In Chapter 8, “Debugging examples using the GUI” on page 431, some scenarios are set up in which these parameters are not fully in place.

To restore an object, perform the following tasks:

1. Under Backup, Recovery and Media Services Tasks, select **Restore iSeries data**, as shown in Figure 7-61.



Figure 7-61 BRMS restore

If you require help, expand **Restore iSeries data** by clicking the green arrow on the same line, as shown in Figure 7-62.



Figure 7-62 BRMS restore, help

2. Select **Restore iSeries data**. A dialog box appears, telling you how to use the next window. Click **OK**, as shown in Figure 7-63 on page 391.

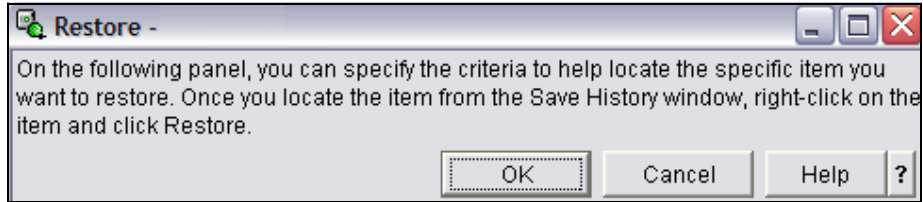

Figure 7-63 BRMS Restore instructions

3. In the window that appears, shown in Figure 7-64 on page 392, fill in details about what to restore, select between dates and other selection criteria, if any. Use **Browse** if required.

The save items window comes up in different shapes, depending on what is to be restored. In this scenario **Library, objects and members** was selected, which allows you to restore a single object, namely the database file PARTS in the library DBITSODB01.

Since a single object named “parts” is being restored, input the following values, and click **OK**, as shown in Figure 7-64 on page 392.

- Policy: itsodbsave
- Saved items:
  - Type: Libraries, objects or members
  - Library: dbitsodb01
  - Object: parts
  - Object type: File

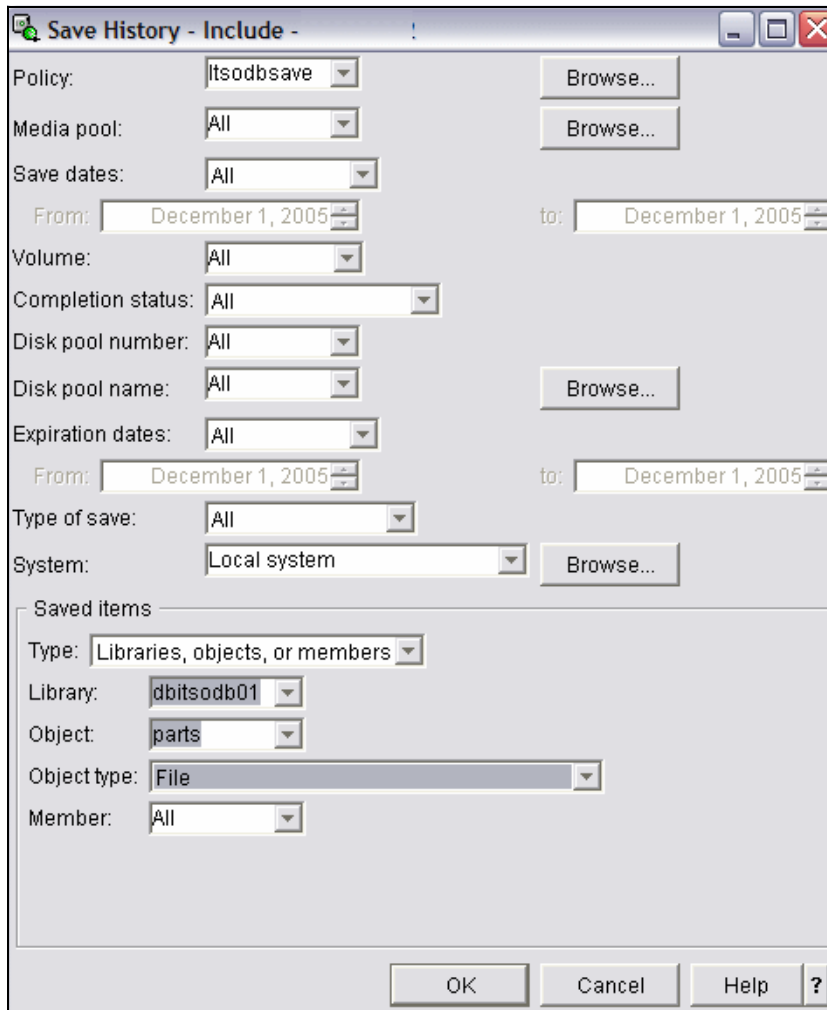

Figure 7-64 BRMS restore, what to restore

The window that appears states that restore task has been started. There is no cause for worry since nothing will happen until you tell recovery from which backup you want to restore.

The Save History window reappears, showing the backups it found based on the recovery selections, as shown in Figure 7-65 on page 393. In this scenario, two choices were provided:

- A backup from November 27
- A backup from November 30

Both are full backups, in which 67 objects were saved.

4. Mark the latest backup (that is, November 30) by double-clicking it as shown in Figure 7-65.

Saved Item	Type	Path	Date	Time	Save Type	Volume	Expirati...	Objects Saved
Parts	File	Library 'Dbitsodb01'	11/27/05	1:56:02 PM	Full	V32k01	11/30/05	67
Parts	File	Library 'Dbitsodb01'	11/30/05	5:24:39 PM	Full	V32k03	12/3/05	67

Figure 7-65 BRMS restore, mark which save

As an alternative, you can right-click a backup and select **Restore**, as shown in Figure 7-66.

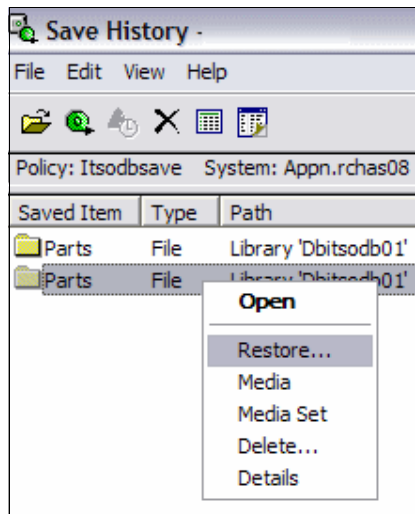

Figure 7-66 BRMS restore, mark which to save

A third option is to click the **Restore** icon, as shown in Figure 7-67 on page 394.

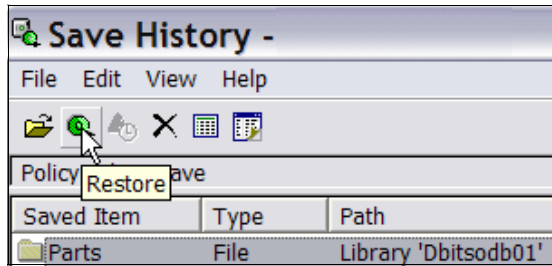

Figure 7-67 BRMS restore, mark which save using Restore button

Now you have to choose whether to restore the entire save or just parts of it. In this scenario, since only one file is being restored, you can specify that you want to restore only one of its members.

We have already specified to BRMS that we are only interested in details at the object level. Consequently, BRMS cannot provide guidance about how many members this file has. Nor can it tell their names.

It should be filled manually if only one member is to be recovered. Select only one object for restore. Select **Restore entire selected save** in the window shown in Figure 7-68 on page 395.

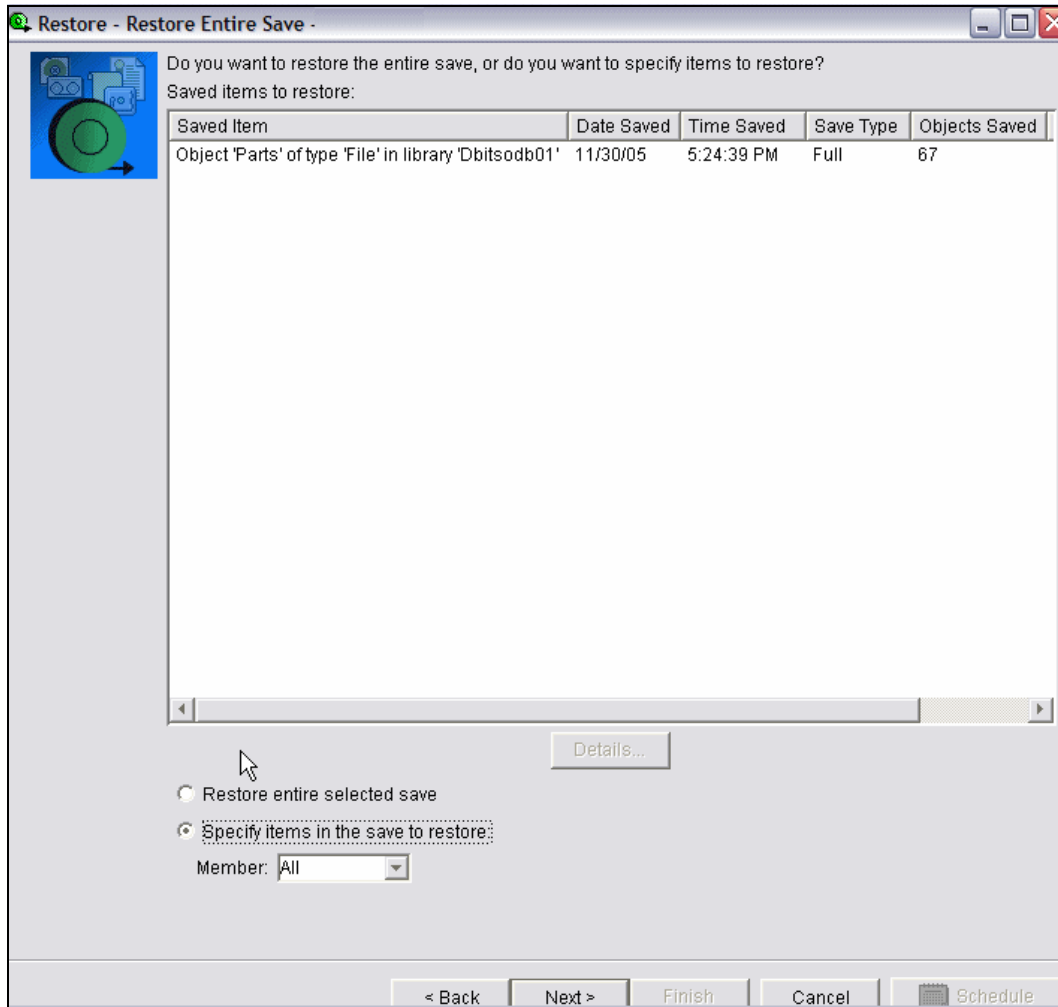

Figure 7-68 BRMS restore, entire save or selected objects?

You can also select specific items. Since a single object (that is, a file) is being saved, the only thing you can select is its members. If you had specified restoring an entire library, other options would have shown up.

Click **Next**.

The second window shown in Figure 7-69 on page 396 asks if you want to restore to the same disk pool or not. Select **Yes, restore to the same disk pool**, and click **Next**.

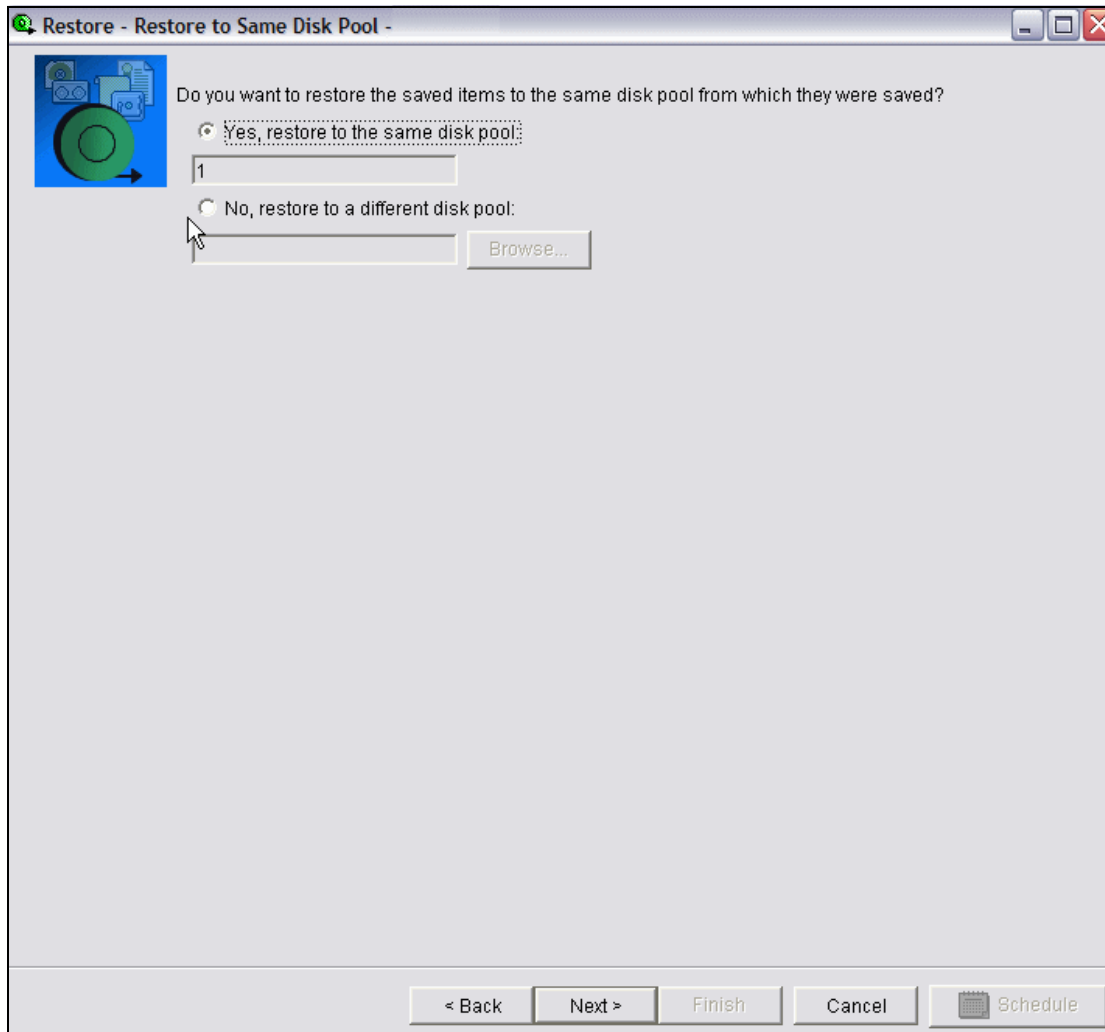

Figure 7-69 BRMS restore, same disk pool

5. To restore to the same location, select **Yes, restore to the same location**, and click **Next**, as shown in Figure 7-70 on page 397.

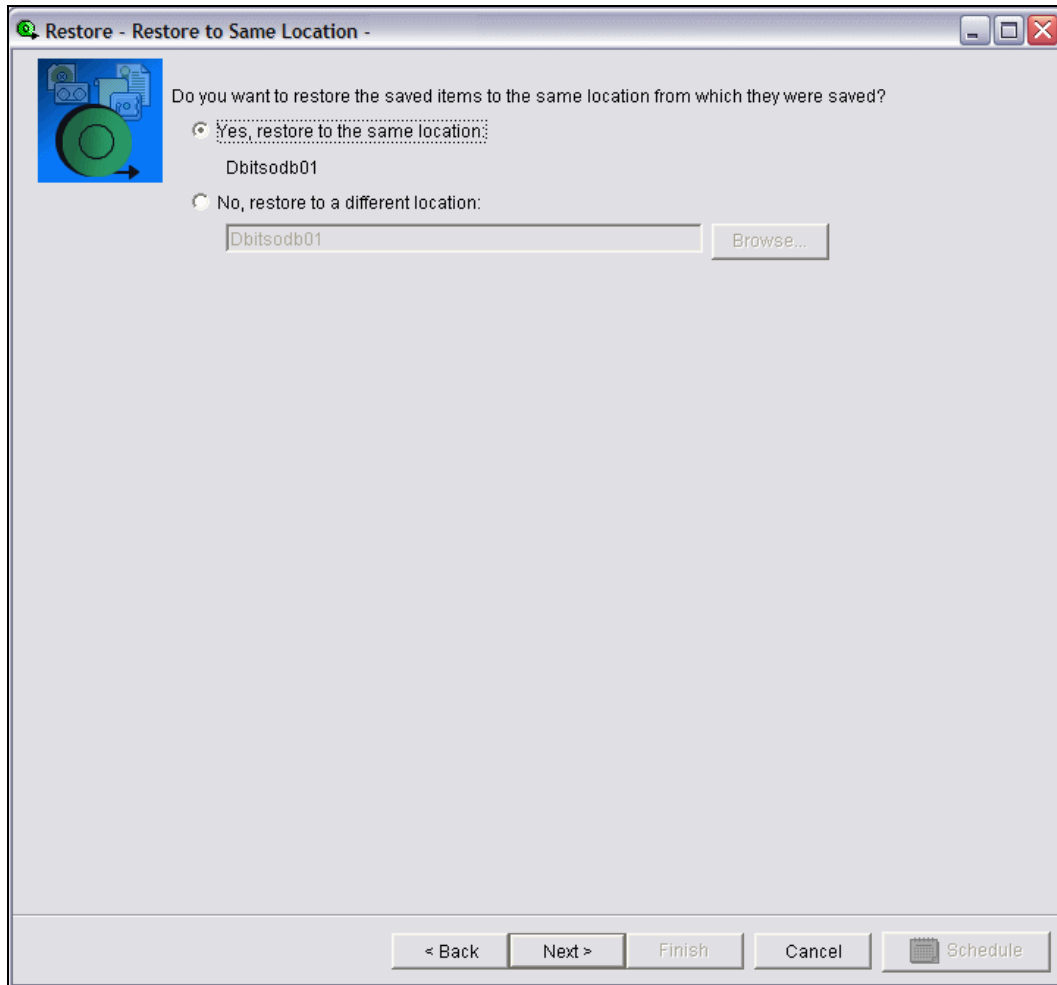

Figure 7-70 BRMS restore, same location

6. Select which tape drive to use. Earlier in this section, it was pointed out that the recovery media should be thought of as a real tape volume that should sit in a tape drive, which in turn should be varied on and be ready, and so on.

To prevent the system from picking a drive pointing to something totally different, select the same tape drive that saved the data on the virtual volumes. Select **Tapvrt01**, click **Add Before** or **Add After**, and click **Next**, as shown in Figure 7-71 on page 398.

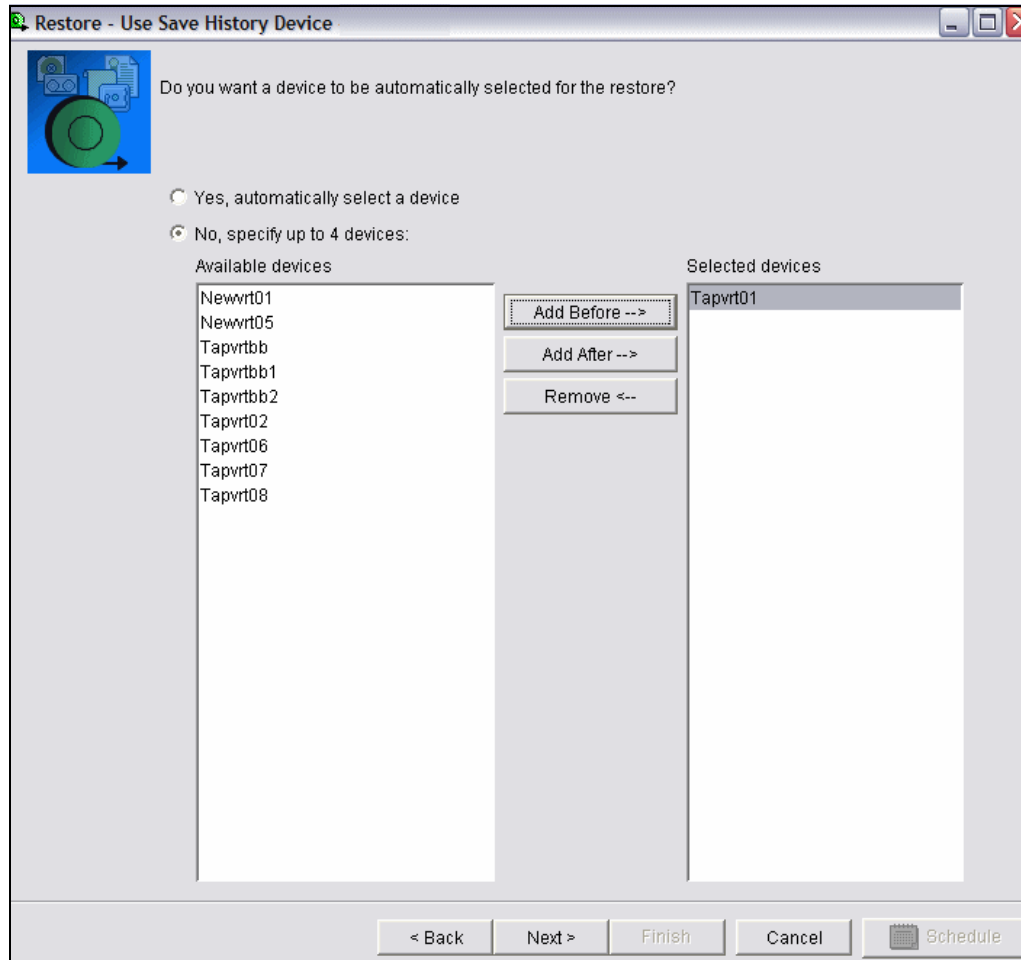

Figure 7-71 BRMS restore, select tape drive

7. The next window, shown in Figure 7-72 on page 399, asks if you want to see the joblog. In this scenario, since we do, click **OK**.

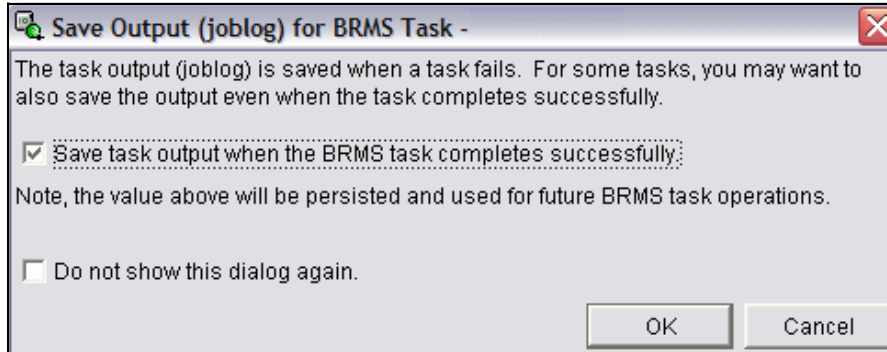

Figure 7-72 BRMS restore, produce joblog

You are now at the point when you can begin restoring. A summary of the selections is shown and you can decide to either run it now or schedule it for a later date.

8. There is one more thing to verify, before finishing the task. Click **Advanced Options** in the Restore Summary window shown in Figure 7-73 on page 400 to do so.

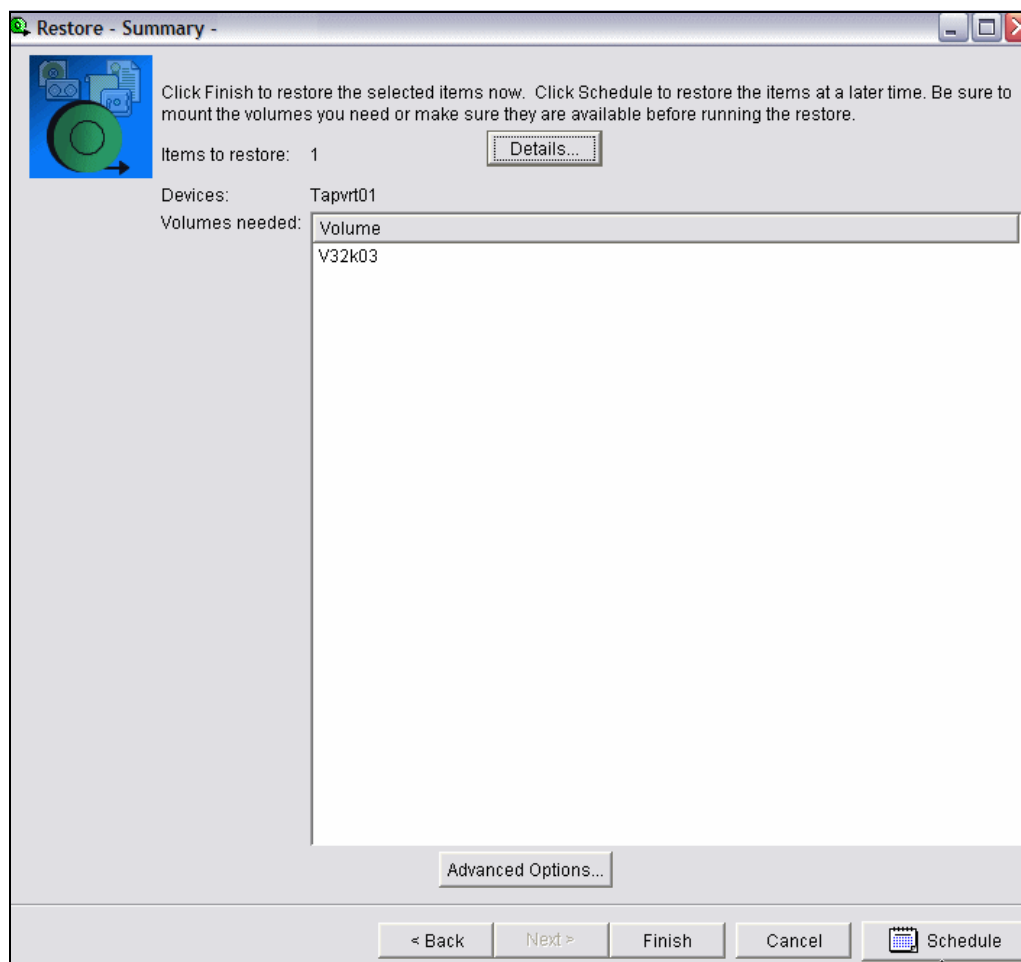

Figure 7-73 BRMS restore, summary

After clicking **Advanced Options...**, specify how you want the tape to behave when done. Should it rewind, unload, or stay in the current position? In a virtual environment, this is not so important. However, keep in mind that the virtual volumes are identical to real physical tape volumes. If you display a volume, it starts from the beginning and seeks its way, sequence number by sequence number, until it finds what it is looking for.

For doing a restore, the approach is a bit different. A tape has called block numbers, which BRMS stores in its databases. When BRMS commands that something be restored, it hands out the block number to the operating system. With that in hand, the tape drive can do a fast positioning to the exact spot where the backup is and immediately start restoring.

This is also the case with append. It directly looks up the last file on the volume and adds the new dataset behind.

**Restriction:** While some tape drives can do fast positioning, others cannot. All virtual drives can.

The Advanced panel offers a few more options, namely, the database members to restore and whether you want to allow differences or not.

9. In this scenario, since nothing else has to be restored, select **Unload** against the End of tape action field in the window shown in Figure 7-74.

Select whatever you find reasonable, and then click **OK**.

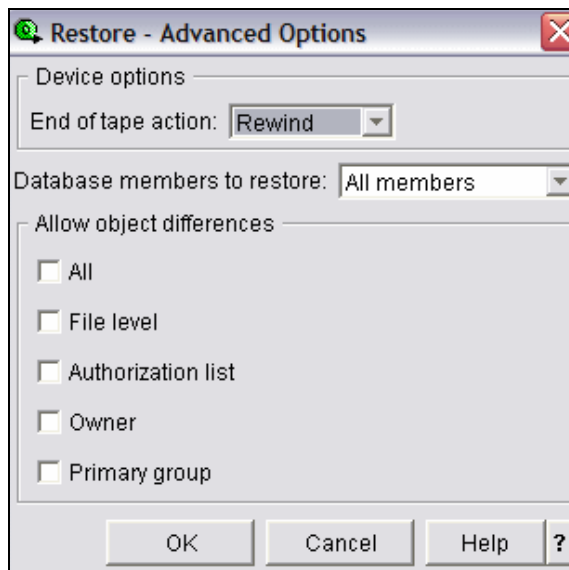

Figure 7-74 BRMS restore, end of tape action plus allow differences

10. This brings you back to the Summary page shown in Figure 7-73 on page 400. Since you have nothing more to add, click **Finish**.

If need be, from the Summary window, you can also schedule it for later execution.

11. This launches the restore, as shown in Figure 7-75 on page 402. Click **OK**.

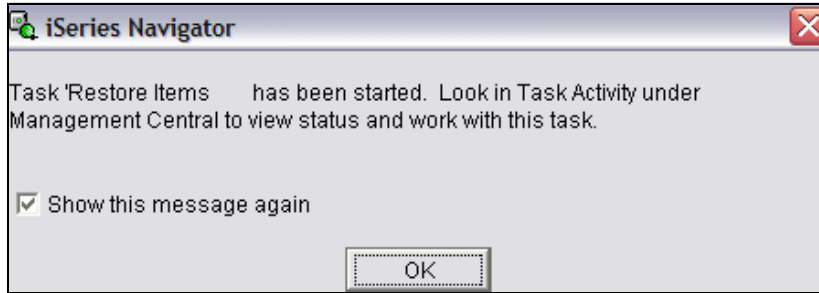

Figure 7-75 BRMS restore, execute

This returns you to the status window shown in Figure 7-76.

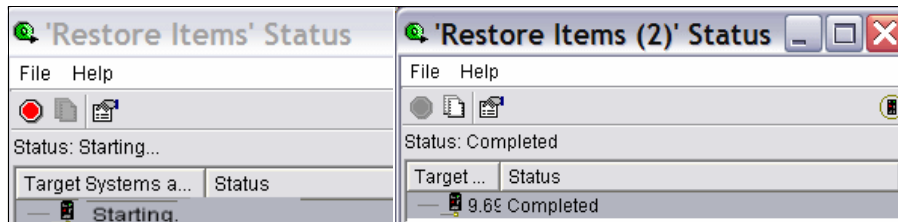

Figure 7-76 BRMS restore, execute status

The restore action is now completed successfully.

### 7.7.1 Determining whether the restore worked

There is a long way and a short way of finding out if the restore worked.

#### The long way

In the Navigator, perform the following tasks:

1. Select **Management Central**.
2. Expand **Management Central** by clicking the plus (+) sign.

3. Select **Backup, Recovery and Media Services**. This shows the jobs that were executed and whether their status is completed or failed, as shown in Figure 7-77.

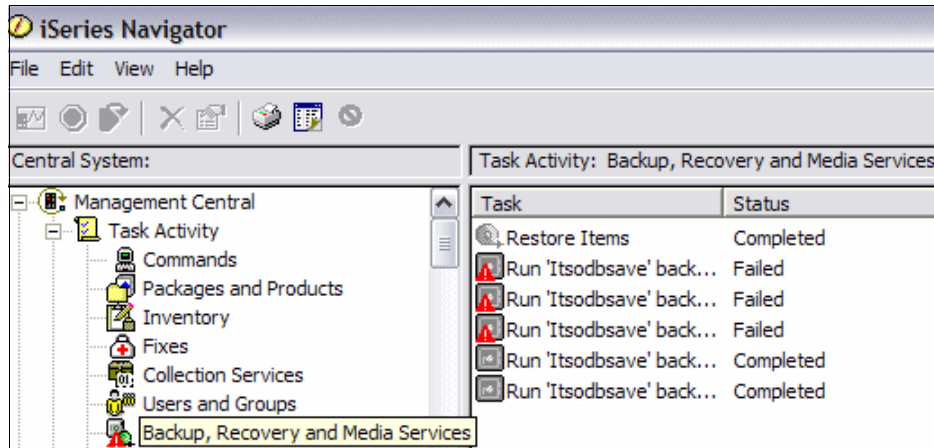

Figure 7-77 BRMS restore, finding out - list of jobs

4. Select your job and click **Task Output**, as shown in Figure 7-78.

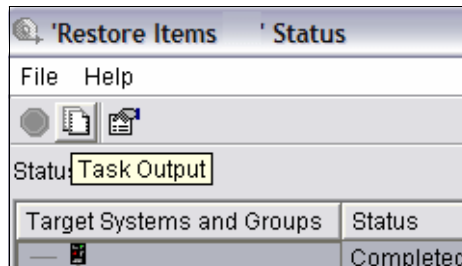

Figure 7-78 BRMS restore - task output

5. This brings up the listings for that job. In this case, it is only the joblog.  
Use the **Open** icon or double-click it, as shown in Figure 7-79 on page 404, to bring up the joblog.

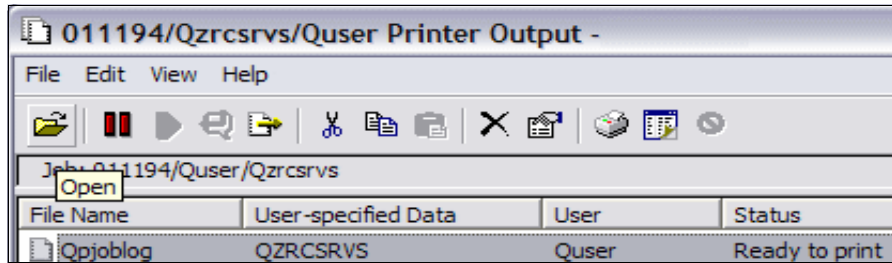

Figure 7-79 BRMS restore, finding out - BRMS restore - task lists

The joblog is displayed, as shown in Figure 7-80. Restoring a single file generates a CPC3703 message stating one object restored.

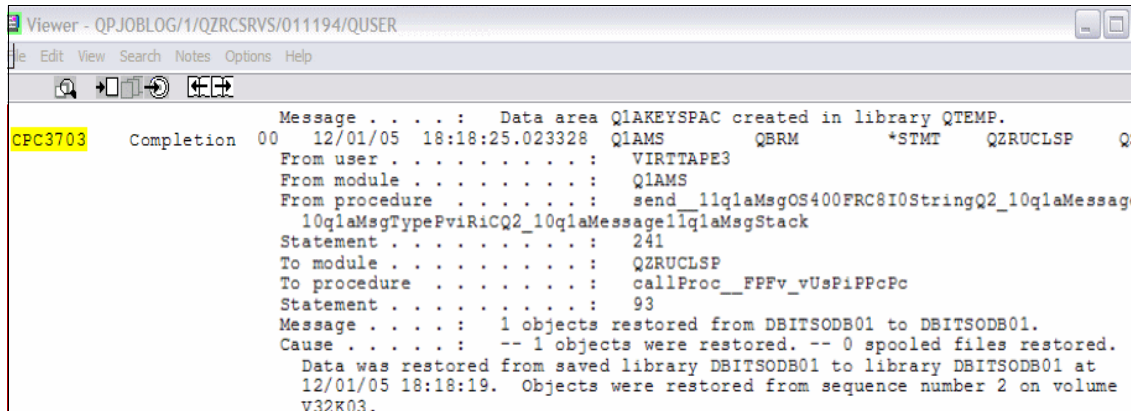

Figure 7-80 BRMS restore, finding out - joblog

If you drill down, you will see some useful information (although it is difficult to read). You can see, for instance, message CPF3722 stating that an older version of PARTS type FILE in DBITSODB01 was restored: The version restored is older than the VOL(\*SAVVOL) version of the object. If the RSTLIB and SAVLIB values are not equal, the save history is lost. Otherwise, the version restored is not the VOL(\*SAVVOL) version and the records of the newer versions are lost.

There is obviously a later backup. In this scenario, BRMS was asked to only look up saves that were done within the control group. It may have been a better idea to specify A11, which would have included all backups of this object.

The joblog also provides the following information: To restore the former VOL(\*SAVVOL) version, specify RSTOBJ OBJ(PARTS) SAVLIB(DBITSODB01)

```
DEV(tape-device-name) OBJTYPE(*FILE) VOL(PAR003) LABEL(DBITSODB01).  
Specify SAVDATE and SAVTIME as 12/01/05 17:17:48.
```

As mentioned earlier, the CPC3703 message states that 1 object was restored. The details against it are: Data was restored from saved library DBITSODB01 to library DBITSODB01 at 12/01/05 18:18:19. Objects were restored from sequence number 2 on volume V32K03.

This message is also sent to the BRMS log. Therefore, in the next section we describe the easy way of seeing whether the restore worked.

## The easy way

The easiest way to determine whether something is restored is to use the BRMS log. There are a number of ways in which you can select information from this log. Follow these steps:

1. Under the Backup, Recovery and Media Services Task bar, open the BRMS log by selecting **Display BRMS Log**, as shown in Figure 7-81.

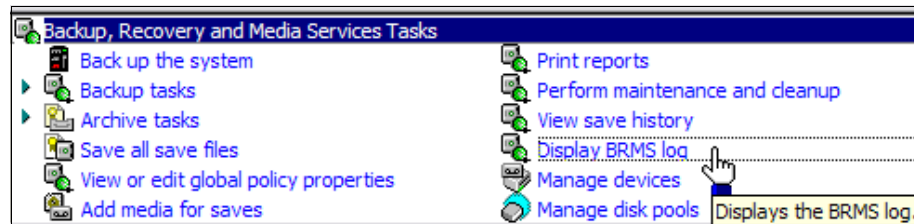

Figure 7-81 BRMS restore - BRMS log using environment tasks

2. The BRMS Log - Include window shown in Figure 7-82 on page 406 appears. Input the appropriate date and time range and click **OK**.

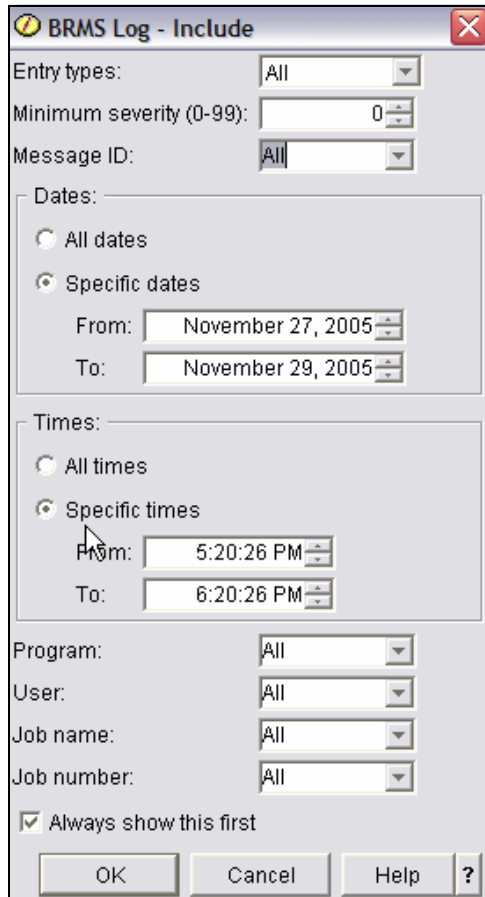

Figure 7-82 BRMS restore - BRMS log includes

This displays a window similar to the one shown in Figure 7-83 on page 407.

Message ID	Severity	Entry Type	Message	Date Sent	Time Sent	User
Brm1143	0	Media	Volume VRTV01 removed from media inventory.	11/28/05	9:11:41 AM	Virttape1
Brm1144	10	Media	Volume VRTV01 with media class VRT256K added to t...	11/28/05	9:13:20 AM	Virttape1
Brm1380	10	Backup	Begin processing for control group AKTEST type *BKU.	11/28/05	9:13:35 AM	Virttape1
Brm1097	0	Backup	Interactive users are allowed to stay active.	11/28/05	9:13:36 AM	Virttape1
Brm1669	10	Backup	Devices TAPVRT07 will be used for control group AKT...	11/28/05	9:13:36 AM	Virttape1
Brm1058	0	Backup	Starting save of library AKTEST* to devices TAPVRT07.	11/28/05	9:13:38 AM	Virttape1
Cpf9898	10	Unknown	CRTTAARA DTAARA(QTEMP/QSRPARFMT) TYPE(*C...	11/28/05	9:13:38 AM	Virttape1
Cpc0904	20	Backup	Data area QSRPARFMT created in library QTEMP.	11/28/05	9:13:38 AM	Virttape1
Brm1315	0	Media	Volume VRTV01 moved.	11/28/05	9:13:39 AM	Virttape1
Cpc3701	20	Backup	11 objects saved from library AKTEST01.	11/28/05	9:15:52 AM	Virttape1
Cpc3701	20	Backup	11 objects saved from library AKTEST02.	11/28/05	9:15:52 AM	Virttape1
Cpc3701	20	Backup	11 objects saved from library AKTEST03.	11/28/05	9:15:52 AM	Virttape1
Cpc3701	20	Backup	11 objects saved from library AKTEST04.	11/28/05	9:15:52 AM	Virttape1
Cpc3701	20	Backup	11 objects saved from library AKTEST05.	11/28/05	9:15:52 AM	Virttape1
Cpc3701	20	Backup	11 objects saved from library AKTEST06.	11/28/05	9:15:52 AM	Virttape1
Cpc3701	20	Backup	11 objects saved from library AKTEST07.	11/28/05	9:15:52 AM	Virttape1
Cpc3701	20	Backup	11 objects saved from library AKTEST08.	11/28/05	9:15:52 AM	Virttape1
Cpc3721	20	Backup	8 libraries saved.	11/28/05	9:15:52 AM	Virttape1
Brm1647	10	Backup	Starting save of media information at level *OBJ to d...	11/28/05	9:15:53 AM	Virttape1
Cpc3701	20	Backup	19 objects saved from library QUSRBRM.	11/28/05	9:15:57 AM	Virttape1

Figure 7-83 BRMS restore - BRMS log entries

As with any information presented in this manner, you can sort the columns by clicking their headers. The next click sorts in the opposite direction. You can expand or shrink the width of the columns if they are too narrow or too wide.

The window shown in Figure 7-84 shows an example of the window after the sorting action.

Message ID	Severity	Entry Type	Message	Date Sent	Time Sent	User
Cpc0904	30	Restore	Data area Q1AKEYSPAC created in library QTEMP.	12/1/05	6:18:24 PM	
Cpc0904	30	Restore	Data area Q1AKEYSPAC created in library QTEMP.	12/1/05	6:18:24 PM	
Cpc3703	30	Restore	1 objects restored from DBITSODB01 to DBITSODB01.	12/1/05	6:18:25 PM	

Figure 7-84 BRMS restore - BRMS log entries severity 30

Double-clicking a message row returns detailed information to you, as shown in Figure 7-85.

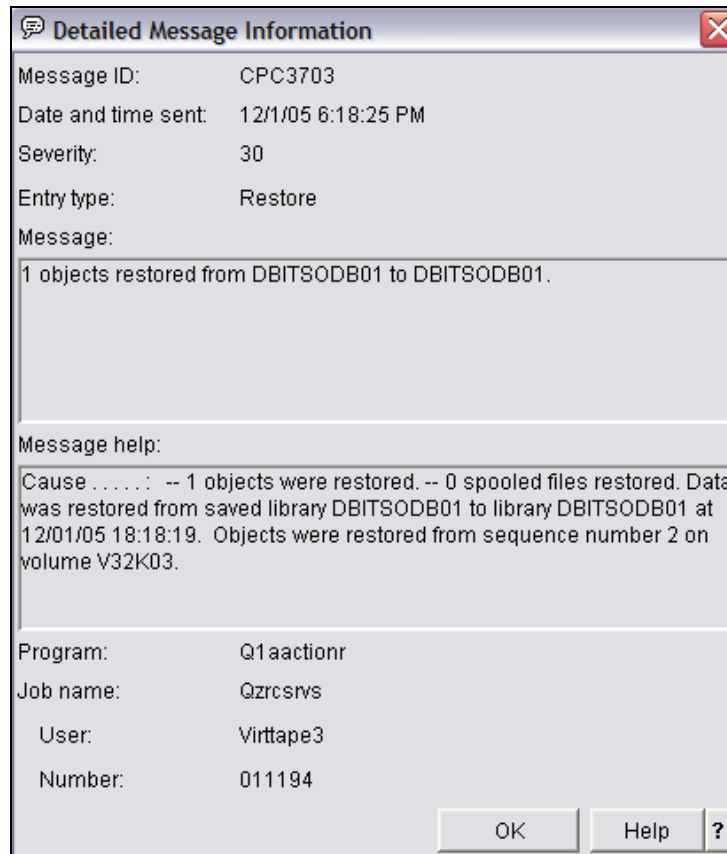

Figure 7-85 BRMS restore, detail message text

This concludes the action of restoring an object.

## 7.8 Duplicating volumes

To secure your data, copy your virtual backup to physical media. In this scenario, only one volume is added.

### 7.8.1 Adding physical tape volumes

To duplicate virtual volumes to real tapes, add the target tapes to BRMS. This is no different from adding physical media.

Following these steps:

1. Under Backup, Recovery and Media Services, right-click **Tape Volumes** and select **Add volumes**, as shown in Figure 7-86.

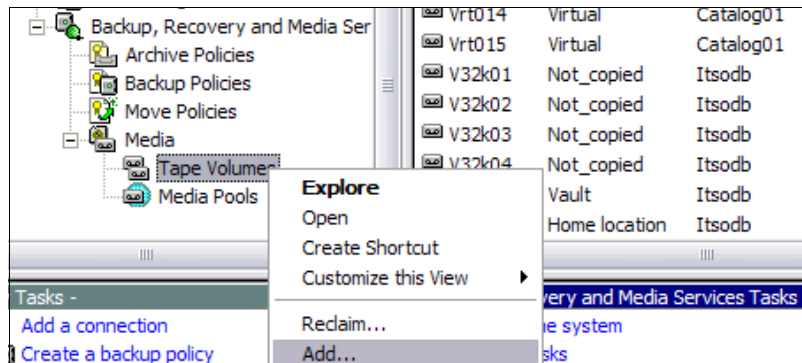

Figure 7-86 BRMS duplicating volumes, add physical media - add volumes

2. In the Welcome wizard window, click **Next**.
3. The next window asks you to specify the media pool in which you want to place your tape volume. Select one that matches your tape drive or your virtual volume.

Remember that you are now creating a tape that may be used for recovery. Since duplicating tape volumes is an ordinary batch job, there is normally no time constraint. The main issue to keep in mind is, what is important for a recovery situation, speed or flexibility.

In this scenario, since the lowest density for the virtual tapes is taken to be flexible, adhere to that concept and select a low density format for the physical tape.

**Important:** Be aware that, although you may have selected the lowest possible virtual volume density, you cannot be certain if a physical low density cartridge can be produced. Most modern physical tape drives do not support writing to low density cartridges. This is because the physical layout of the tape drives' read and write heads are different. Typically, a high-density drive divides the tape surface into more stripes and writes the bits closer to each other.

Make your choice and click **Next**, as shown in Figure 7-87 on page 410.

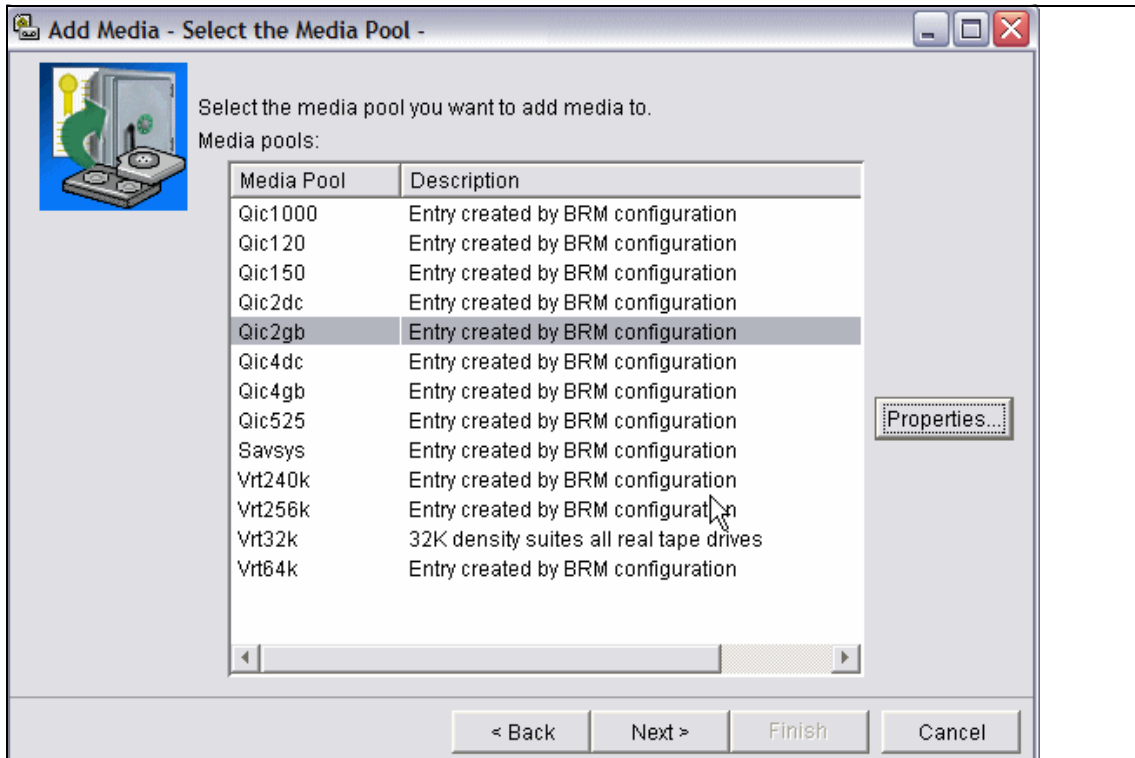

Figure 7-87 BRMS duplicating volumes, add physical media - select media pool

4. In the Add volumes window that appears, type the volume name and click **Add**. Repeat until all the volumes are added to BRMS.

In this scenario, only one is added. Click **Next**, as shown in Figure 7-88 on page 411.

**Important:** Volume names should be unique even across systems.

Avoid misleading names such as Monday, and so on, even if you only have a single drive. There is a definite chance of such a naming scheme breaking when the tape for Wednesday has to be mounted on Saturday.

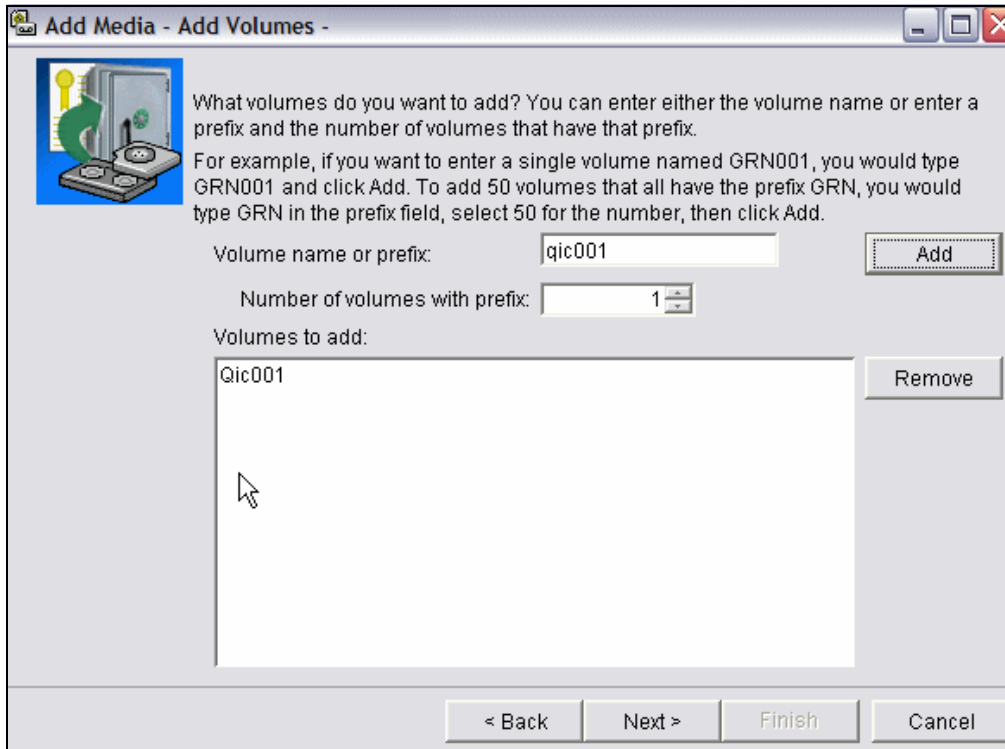

Figure 7-88 BRMS duplicating volumes, add physical media - add named volumes

5. Add your volume to a location, as shown in Figure 7-89 on page 412.

The quarter-inch tape drives are not tape libraries. They are only simple, single drives. They do not even have a tape loader, so a location does not really apply to them. At this point, you can create locations TAP01, TAP02, and so on, but there is little benefit in doing so, since they can only hold one volume at a time.

In this scenario, the example tape is placed in location \*HOME.

As discussed earlier, every volume has to be in a location. This is especially important to physical media. BRMS always creates a location named VAULT, which is used in this example. However, you should also know where your physical scratch tapes are. If you have a tape library, they will be there. If you have only a single drive (as is the case in this scenario), it is beneficial to have a location named TAPESHELF, COMPROOM, DRAWER, or whatever suits you best. Since \*HOME is also possible, it is used here.

Click **Next**.



Figure 7-89 BRMS duplicating volumes, add physical media - add volumes to location

6. Initialize volumes in the window shown in Figure 7-90 on page 413. However, since the volume is already initialized in this scenario, skip that and click **Next**.

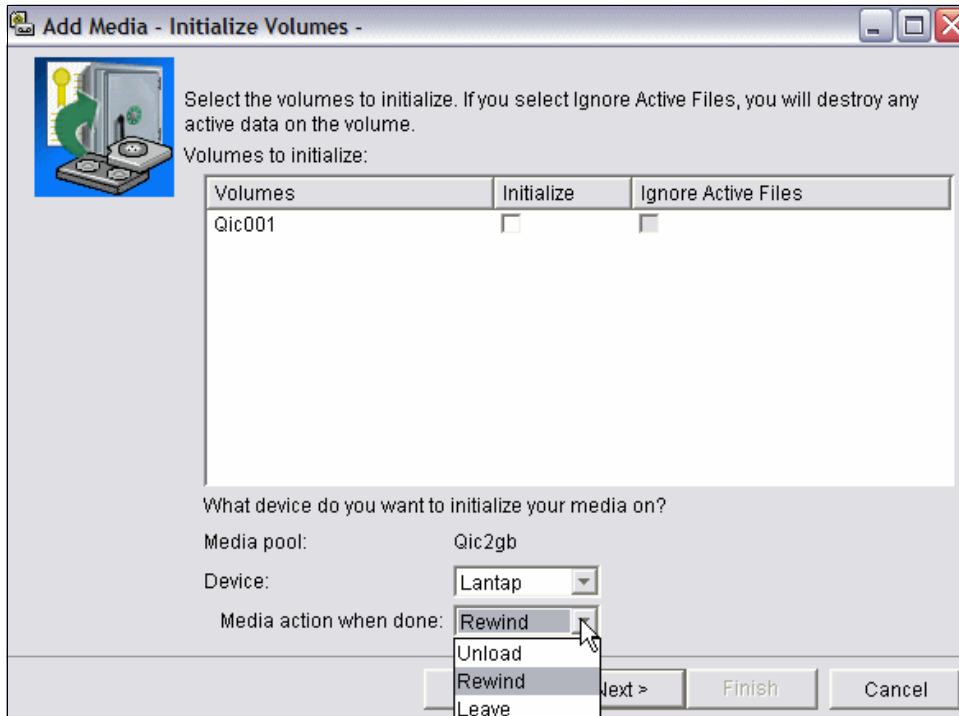

Figure 7-90 BRMS duplicating volumes, add physical media - initialize volumes

**Tip:**

- ▶ If you initialize only one volume, change **Media action when done** from Unload to Rewind.
- ▶ If you initialize more than one volume, take them in reverse order so that the first to be used can be left in the drive.

7. As there is nothing else to be done, in the Summary window shown in Figure 7-91 on page 414, click **Finish**.

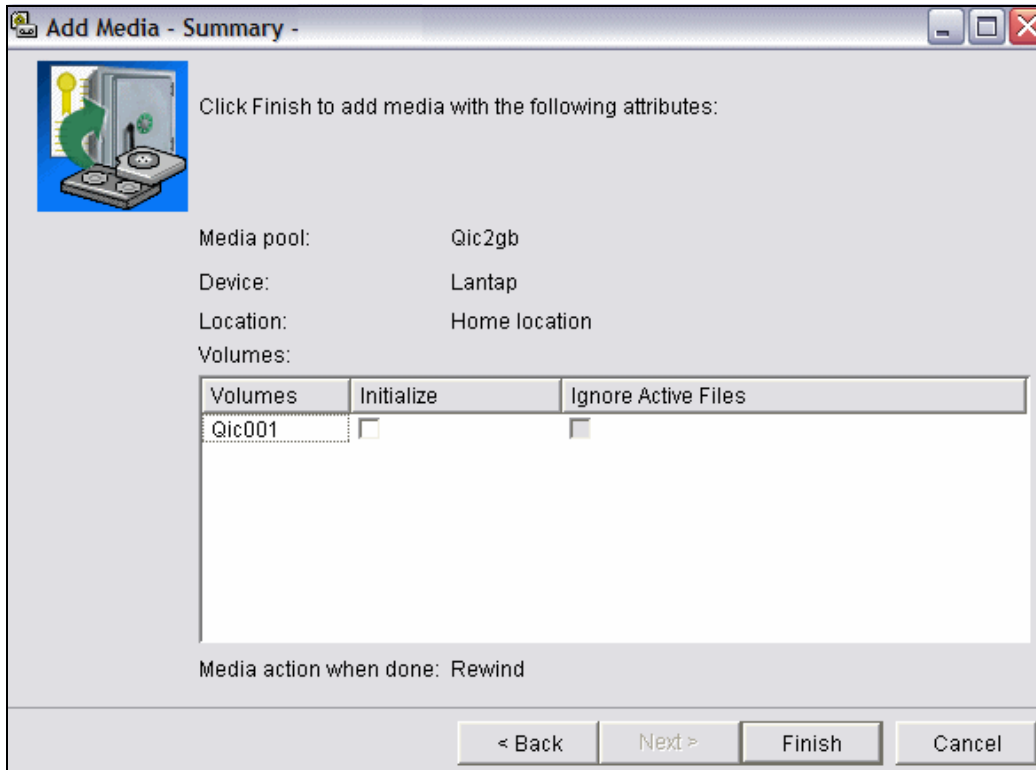

Figure 7-91 BRMS duplicating volumes, add physical media - summary

**Important:** BRMS has its own way of keeping track of retention periods. Physically, all BRMS tapes have \*PERM (permanent) as retention period to avoid having them overwritten if they are loaded into another system.

If you add a tape volume to BRMS, it assumes that the volume is empty and adds it as \*EXPIRED. You will lose whatever was on that volume regardless of whether you initialized it or not.

If the volume is unknown to BRMS and you want to keep the data intact, but let BRMS add data to the same volume, use the 5250 commands Add Media Information to BRM (ADDMEDIBRM) and Extract Media Information to BRM (EXTMEDIBRM). You should also set an appropriate retention period for the volume manually.

8. Click **Finish** in Figure 7-91 to return to the window where you started, as shown in Figure 7-92 on page 415. Press F5 for refresh.

Volume	Location	Image Catalog	Status	Expired	Media Pool	Marked
Vrt013	Virtual	Catalog01	Expired	Yes	Vrt256k	No
Vrt012	Virtual	Catalog01	Expired	Yes	Vrt256k	No
Vrt011	Virtual	Catalog01	Expired	Yes	Vrt256k	No
Vrt010	Virtual	Catalog01	Expired	Yes	Vrt256k	No
Vrt009	Virtual	Catalog01	Expired	Yes	Vrt256k	No
Vrt008	Virtual	Catalog01	Expired	Yes	Vrt256k	No
Vrt007	Virtual	Catalog01	Active	No	Vrt256k	Yes
Vrt005	Virtual	Catalog01	Active	No	Vrt256k	Yes
Vrt004	Not_copied	Catalog01	Active	No	Vrt256k	Yes
Vrt003	Virtual	Catalog01	Active	No	Vrt256k	Yes
Vrt002	Virtual	Catalog01	Active	No	Vrt256k	No
Vrt001	Virtual	Catalog01	Active	No	Vrt256k	No
Qic001	Home location		Expired	Yes	Qic2gb	No

Figure 7-92 BRMS duplicating volumes, add physical media - done

This concludes the first part of duplicating virtual volumes. You now have a physical tape volume that BRMS is aware of and knows where it is.

## 7.8.2 Duplicating volumes

At the time of writing, duplication using the Navigator could not be done.

The only other option was to use 5250 emulation. Perform the following tasks to duplicate volumes here:

1. Start a 520 emulation screen (if that has not already been done).

If you do not have a shortcut to the screen, from the Windows Start panel, select **Programs** → **IBM iSeries for Windows** → **Emulator** → **Start or Configure sessions**, as shown in Figure 7-93 on page 416, and create a path if none exists.

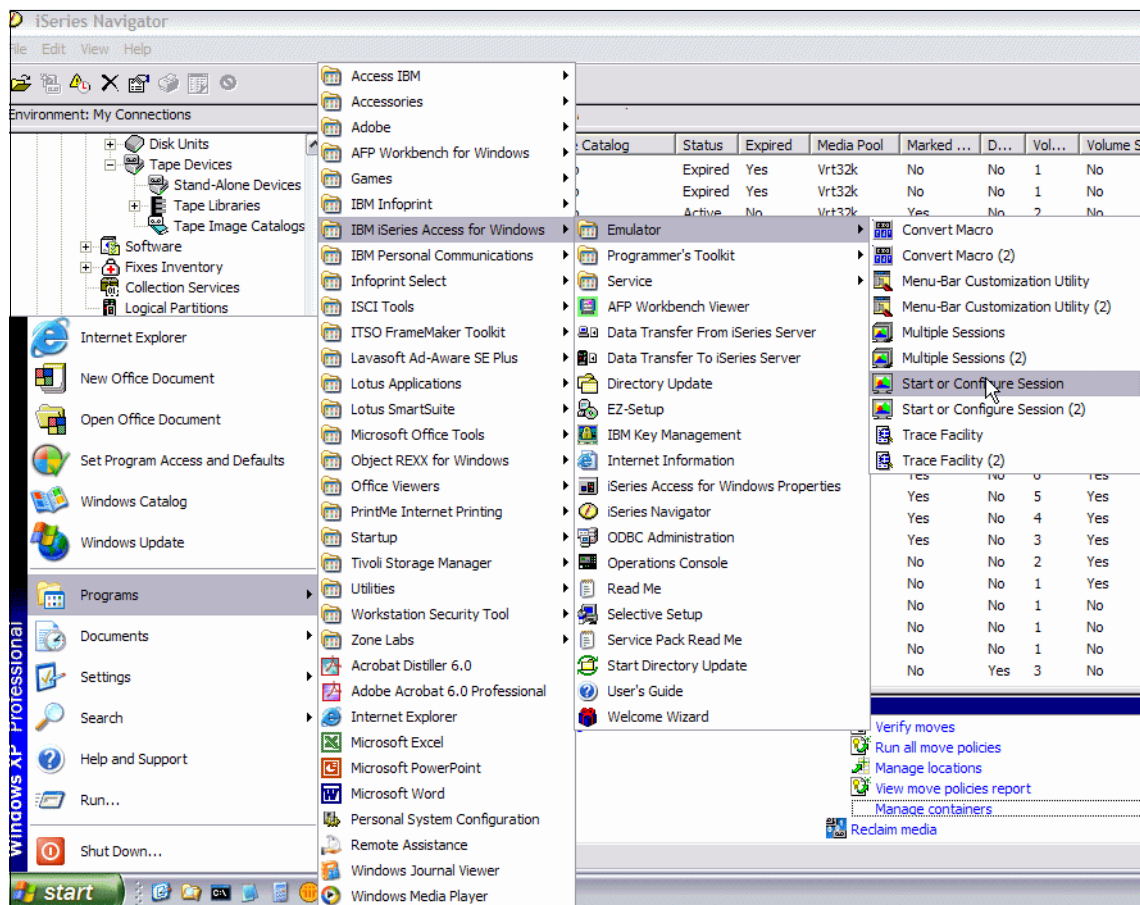

Figure 7-93 BRMS duplicating volumes - Start 5250 emulation

A media policy is required for the iSeries physical volumes. Only in 5250 emulation, does a Media policy exist on its own. In the Navigator it is not a separate entity, and is built in under the backup policy.

- To access the media policy in 5250 emulation, enter the following command and press Enter:

```
WRKPCYBRM *MED
```

Select **Option 1 = Create**.

In this scenario, the Media policy is named TWO\_WEEKS and the retention period is set to 17 days to cover for long weekends.

Since this media policy deals with physical tapes, a move policy is required. BRMS always creates a base setup, which includes a move policy named

OFFSITE. It ensures that the volumes are stored in a safe place. Determine an appropriate logical flow for your volumes that suits your business, and create as many locations as required. In this scenario, the OFFSITE move policy is used as shown in Example 7-1.

*Example 7-1 BRMS duplicating volumes, create Media policy for physical media*

Create Media Policy

Type choices, press Enter.

```

Media policy . . . . . TWO_WEEKS   Name
Retention type . . . . . 2           1=Date, 2=Days,
                                       3=Versions, 4=Permanent
Retain media . . . . . 17           Date, Number
Move policy . . . . . OFFSITE       Name, *NONE, *ADSM, F4
Media class . . . . . QIC2GB        Name, *SYSPCY, *ADSM, F4
Storage location . . . . . *ANY      Name, *ANY, F4 for list
Save to save file . . . . . *NO      *YES, *NO
  ASP for save files . . . . . *SYSTEM Name, *SYSTEM, 1-32
  Save file retention type . . . . . 4 1=Date, 2=Days,
                                       3=Permanent, 4=None
    Retain save files . . . . . *NONE Date, Number, *NONE
  ASP storage limit . . . . . *SYS   *SYS, 1-99
Secure media . . . . . *NO          *YES, *NO, *ADSM
Text . . . . . Media policy used for physical media saved 17 days
                                                More...
F3=Exit  F4=Prompt  F5=Refresh  F12=Cancel

```

3. When done, you can duplicate by entering the following values for the parameter DUPMEDBRM and pressing Enter:

- VOL: V32K02
- FROMDEV: TAPVRT01
- TODEV: TAP01
- MEDPCY: TWO\_WEEKS
- FROMVOL: V32K02
- FROMENDOPT: \*REWIND
- TOENDOPT: \*UNLOAD
- TOVOL: QIC001
- SAVMEDINF: \*OBJ

This job failed because it filled up the volume. Unfortunately, since there were no volumes ready for that media class, the job had to be cancelled as shown in the following message example.

No media of class QIC2GB is available in location \*HOME:

- Reply . . : C

The joblog appears as shown in Example 7-2.

*Example 7-2 BRMS duplicating volumes, unsuccessful joblog*

---

Tape duplication completed successfully.  
Duplication mark for volume V32K02 removed.  
Save or restore operation ended unsuccessfully.

---

**Note:** The message Tape duplication completed successfully is a bit contradictory to the last message Save or restore operation ended unsuccessfully.

This is because the saved library fit on the volume. What did not fit, however, were the BRMS inventory files needed for disaster recovery.

Since the data was copied correctly, the duplication mark was removed from virtual volume V32K02.

4. There is an easy way of solving the problem of the duplication making it only half-way through. Add another cartridge to BRMS and restart with the following command:

```
ADDMEDBRM VOL(QIC101) MEDCLS(QIC2GB) INZ(*YES) DEV(TAP01)
```

Then press Enter.

As an alternative, you can restart from a failing point by using the DUPMEDBRM command. Use the following command:

```
WRKMEDIBRM VOL(V32K02)
```

Then press Enter.

Press F11 until you see the columns shown in Example 7-3.

*Example 7-3 BRMS duplicating volumes, WRKMEDIBRM - Resume key*

---

Saved Item	Save Date	Save Time	Item Type	Duplicate Save Item	Marked for Duplication	Duplication Resume Key
DBITS0DB01	12/05/05	15:59:43	*LIB	*YES	*NO	
QUSRBRM	12/05/05	16:00:45	*OBJ	*YES	*NO	012612

---

Replace the Volume Name and RSMKEY in the DUPMEDBRM command with the following values:

- VOL: \*RESUME
- RSMKEY: 012612

The other parameters stay the same. Press Enter.

Example 7-4 on page 419 shows the job log, which states that tape duplication is complete.

*Example 7-4 BRMS duplicating volumes, joblog complete*

---

Tape duplication completed successfully.  
Save of BRM media information at level \*OBJ complete.  
19 objects saved from library QUSRBRM.  
Tape duplication completed.

---

You can see that the target volumes automatically moved to location OFFSITE, as outlined by the move policy that was used in the copy operation.

5. Use the following command to verify the volumes:

```
WRKMEDBRM
```

Then press Enter.

Example 7-5 shows that the target volumes have moved to a new location.

*Example 7-5 BRMS duplicating volumes, target volumes moved to new location*

---

Volume Serial	System	Move Policy
QIC001	APPN.SYSAS08	OFFSITE
QIC101	APPN.SYSAS08	OFFSITE

---

**Note:** We should point out that the example provided here is not very realistic. First of all, there is little meaning in saving BRMS media inventory to virtual volumes. Normally, you cannot take them anywhere. In a running system, BRMS has all the latest information it requires on its online inventory databases. However, there is a risk if something negative happens between the time of your backup and the time when these inventory files are saved to physical media.

Also, the resulting volume ended up with two sets of BRMS inventory files, with the first set reflecting the time the original backup was taken. Everything in there points to the virtual tape, which is essentially worthless if you have to run to a recovery site, since you normally cannot bring your virtual volumes along. The second inventory set is the only useful one, as it now points out the real physical volume as the recovery media for our data.

## The recovery report

The recovery report correctly points to the physical volume QIC001. The refers to restoring only library DBISTODB01, which is fitted on tape QIC001. Therefore, the recovery report does not list volume QIC002 here. QIC002 contains only the BRMS media inventory files.

The recovery report is normally a result of the BRMS maintenance job. However, you can produce a recovery report by using the following command:

```
STRRCYBRM
```

Then press Enter.

Example 7-6 shows a recovery report.

*Example 7-6 BRMS duplicating volumes, recovery report - selection only*

Saved Item	Save Type	----- ASP Name	----- Number	Save Date	Save Time
DBITSODB01	*FULL	*SYSBAS	00001	12/05/05	15:59:43

--- Objects ---

Not Saved	Sequence Number	Control Group	Volume Identifier
67	0	1 ITSODBSAVE	QIC001

**Note:** The disaster recovery report shows whatever date and time range you have specified; that is, the volumes and instructions required to recover the system up to that point in time. It does not show any previous versions of the data.

To restore older generations, pick a volume that is not yet overwritten, and use the Work with Media Information (WRKMEDIBRM). The results are shown in Example 7-7.

*Example 7-7 BRMS duplicating volumes, WRKMEDIBRM*

Saved Item	Save Date	Save Time	Save Type	Parallel Devices	Volume Serial
DBITSODB01	11/27/05	13:56:02	*FULL		V32K01
DBITSODB01	11/30/05	17:24:39	*FULL		V32K03
DBITSODB01	12/05/05	15:59:43	*FULL		V32K02
DBITSODB01	12/05/05	15:59:43	*FULL		QIC001

**Note:** The target volume from duplication has the same date and time stamp as the volume it was copied from.

## Finding what to duplicate automatically

In this scenario, a specific volume to copy (that is, V32K02) was used as an example. However, you can also duplicate volumes using two other useful

parameters in the DUPMEDBRM command, namely \*SEARCH and \*SCHHST, as described here:

▶ \*SEARCH

This duplicates complete volumes.

▶ \*SCHHST

This only duplicates data sets that are not already copied.

For more information about these parameters, refer to their help text.

To specify that you only want specific datasets to be marked for duplication, go to the Backup Policy Properties, under Advanced, in the During tab, as shown in Figure 7-94.

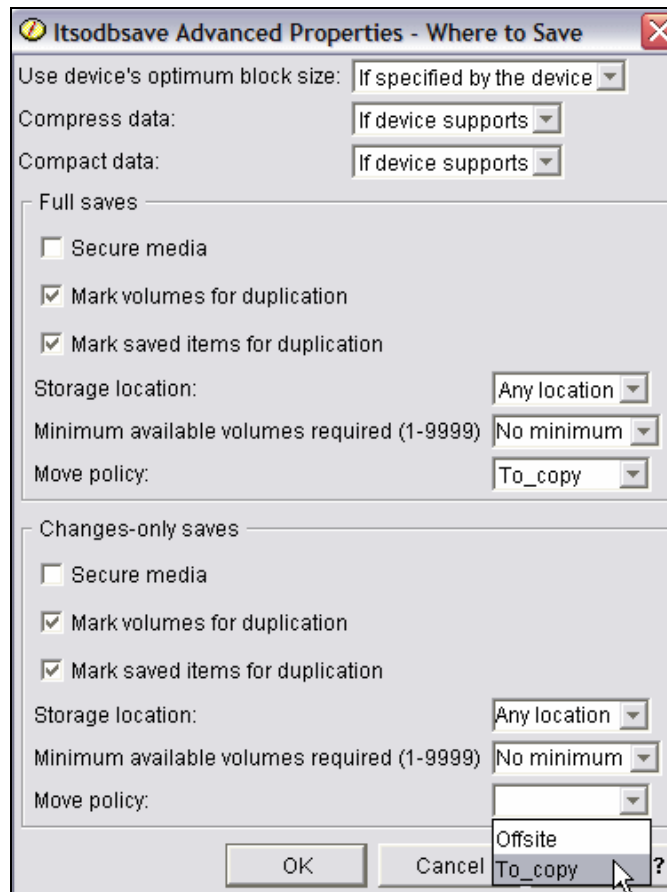

Figure 7-94 BRMS duplicating volumes, mark datasets for duplicate

**Note:** You cannot run several \*SEARCH or \*SCHHST jobs at the same time or in combination. The result will be unpredictable.

This concludes the recovery action.

## 7.9 Parameters available only from Navigator

The naming convention differs between Navigator and the 5250 emulation. In Navigator, both the backup policy and the control group are combined in one task. The backup policy in 5250 is more of a general definition containing default parameters that the system policy does not specify.

The backup policy in 5250 also overrides anything in the system policy if they both contain the same variable. What really counts is the control group, which overrides everything.

When displaying a control group in 5250 emulation, there are some attributes you cannot touch. They are shown, but you cannot change them. They are controlled from the Navigator only; for example, the last page of a 5250 control group (the direct command is WRKCTLG) shown in Example 7-8.

*Example 7-8 BRMS Navigator only, 5250 Control group - attributes*

---

```
Client backup policy . . . . . : SERVERBACK

Allow activity overrides . . . . . *YES
Allow retention overrides . . . . . *YES
Additional management:
  TCP/IP servers . . . . . *BOTH
  Lotus servers . . . . . *BOTH
  Integrated Windows servers . . . . . *BOTH
  Guest partitions . . . . . *BOTH
Unmount user-defined file systems . . . *YES
Run maintenance after backup . . . . . *NO
```

---

Some attributes are specified when you create the backup policy by selecting options such as **Yes, unmount user-defined file systems**, as shown in Figure 7-95 on page 423.

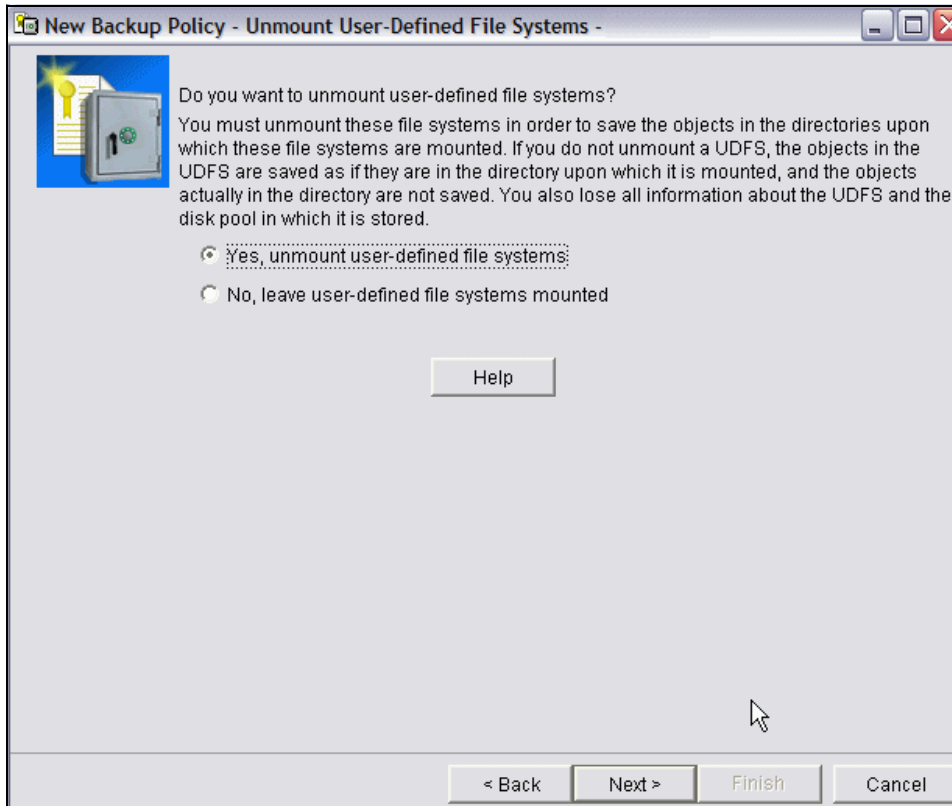

Figure 7-95 BRMS Navigator only, unmount file systems

Other attributes hide behind the tabs, shown in Figure 7-96 on page 424, in an existing backup policy.

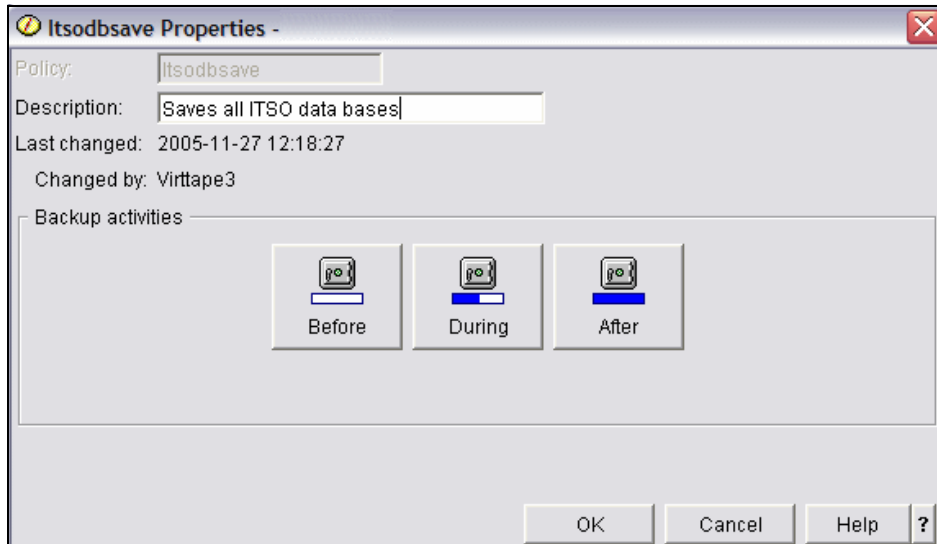

Figure 7-96 BRMS Navigator only, properties buttons - Before, During, After

Against Before are the following parameters, as shown in Figure 7-97 on page 425:

- ▶ Shut down integrated file servers
- ▶ Shut down hosted logical partitions
- ▶ Shut down TCP/IP servers
- ▶ Shut down Lotus servers

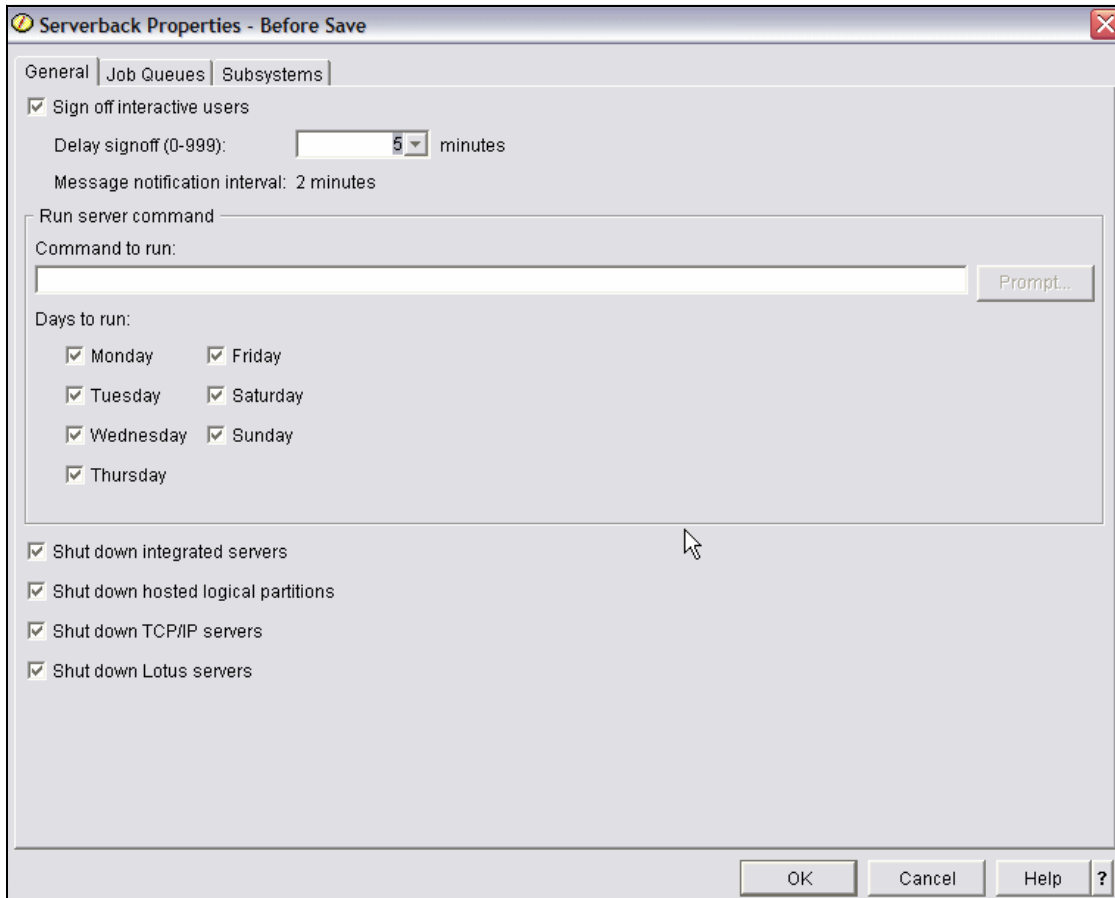

Figure 7-97 BRMS Navigator only, before save - General tab

Against During, What is one of the tabs. It has a parameter at the bottom stating Unmount user-defined file systems, as shown in Figure 7-98 on page 426.

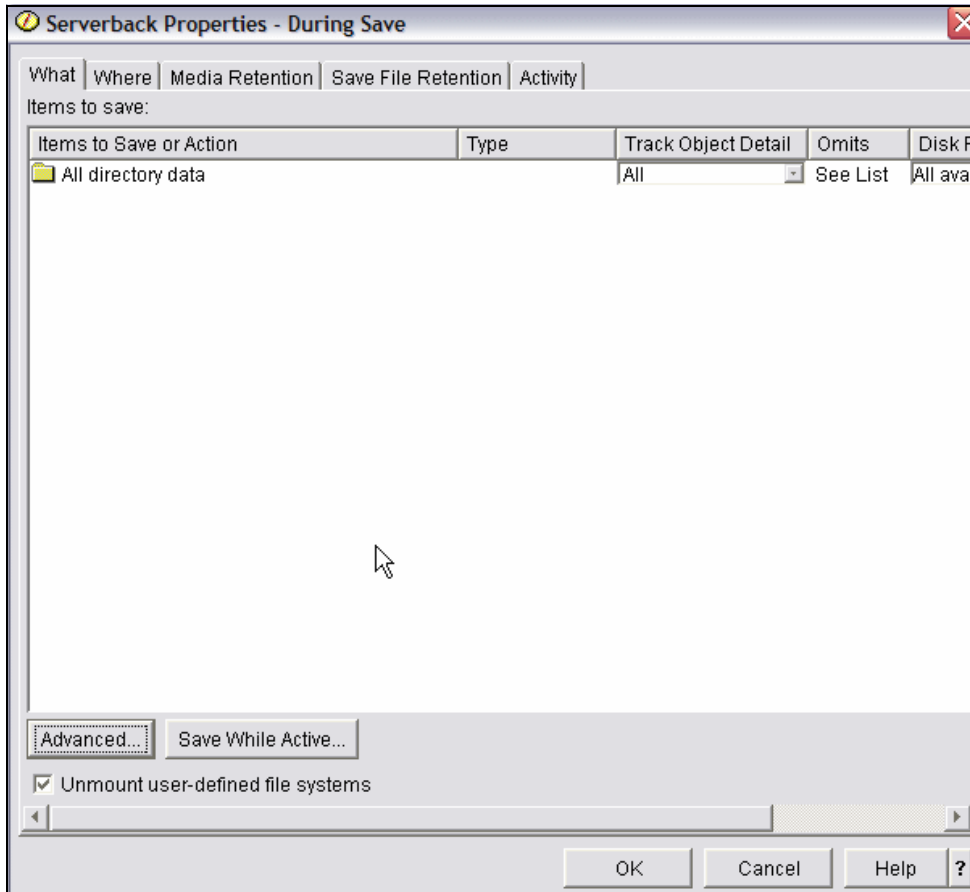

Figure 7-98 BRMS Navigator only, during save - What tab

Against After are the options used to start whatever you took down under Before, as shown in Figure 7-99 on page 427.

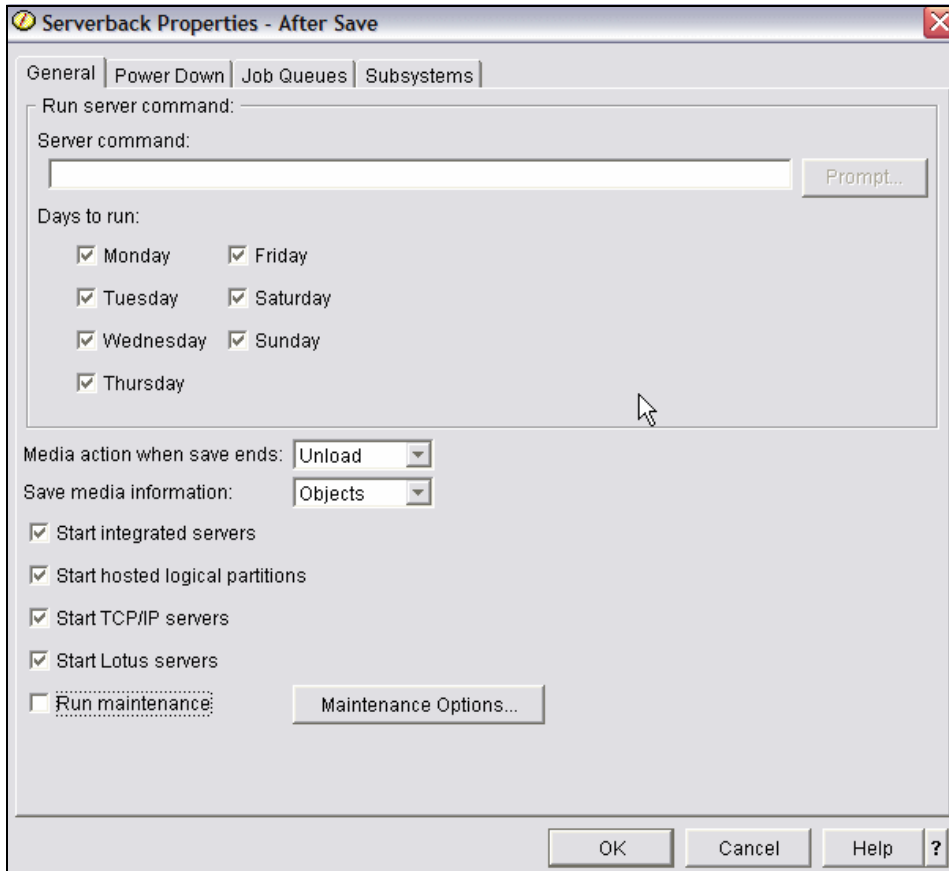

Figure 7-99 BRMS Navigator only, after save - General tab

This concludes the section on the BRMS parameters available only from the Navigator.

## 7.10 Adding a new tape drive to BRMS

Assume that you have created a virtual tape device named TAPVRT03, and it is the one you want to use in the backup policy. In the Stand-Alone Devices list

shown in Figure 7-100, you see this virtual tape drive, but it does not appear on the BRMS list of available devices.

Stand-Alone Devices		
Tape Device	Status	Type-Model
Japvrttap1	Available	6380-001
Jjpvrttap	Available	6380-001
Lantap	Unavailable	6380-001
Tapvrt01	Available	6380-001
Tapvrt02	Unavailable	6380-001
Tapvrt03	Unavailable	6380-001
Tap01	Unavailable	6382-001
Tap03	Unavailable	3570-C12
Tap04	Unavailable	3570-C12

Figure 7-100 BRMS Backup policy, list of Stand-Alone devices

There are two ways of fixing this:

1. In 5250 emulation, enter the following command:

```
INZBRM *DEVICE
```

As an alternative, you can bring up **Manage devices** using the Navigator, as shown in Figure 7-101. (The example used here is from another system.)

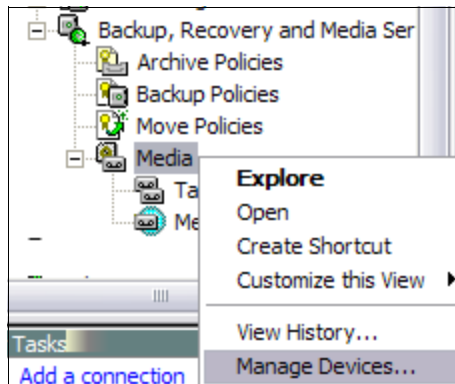

Figure 7-101 BRMS Backup policy, Manage devices

2. Click **New Media Device** to add TAPVRT03, as shown in Figure 7-102 on page 429.

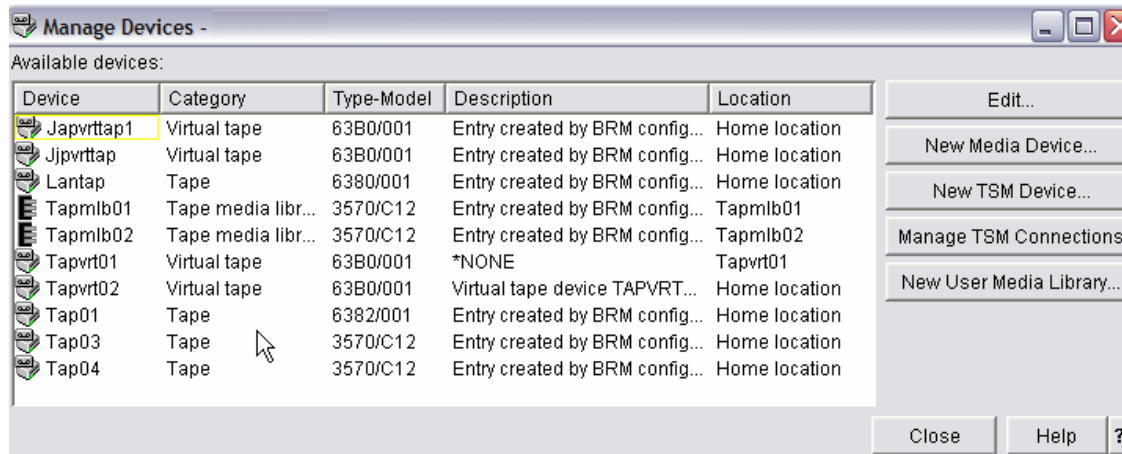

Figure 7-102 BRMS Backup policy, manage devices

3. This makes BRMS search for any device it does not yet know. It finds TAPVRT03 and it brings it up for tailoring, if required.  
Finish by clicking **Add**, as shown in Figure 7-103.

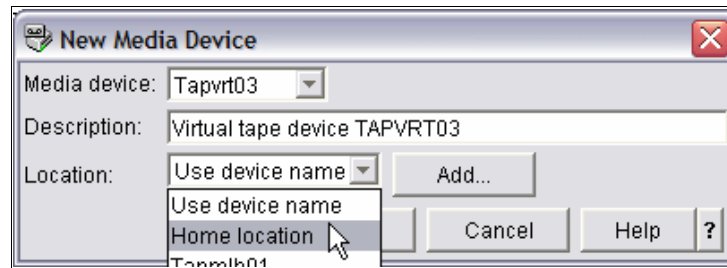

Figure 7-103 BRMS Backup policy, add new device to BRMS

4. Refresh by pressing F5. The new tape device should now be visible and ready to use in BRMS.

## 7.11 Reinstating dialog boxes

At some point you may have indicated that you are not interested in joblogs from successful jobs and that you do not wish to see the dialog box again.

However, if you later change your mind, you can reinstate the dialog box by right-clicking Backup, Recovery and Media Services and selecting **Enable BRMS Dialogs**, as shown in Figure 7-104.

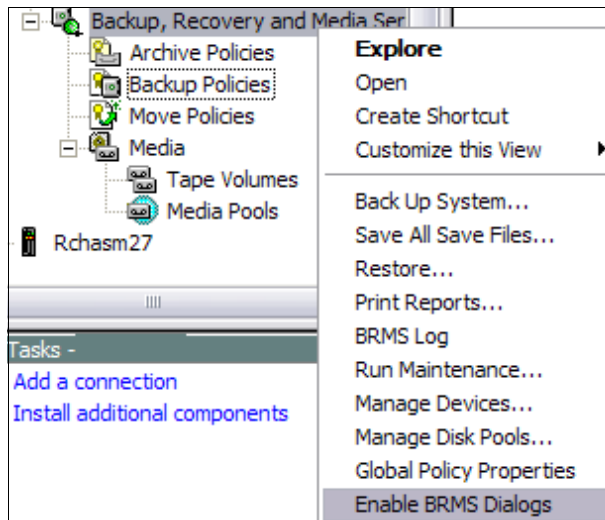

Figure 7-104 BRMS enable dialog boxes



## Debugging examples using the GUI

This scenario is a follow-up to Chapter 6, “BRMS and virtual tape” on page 279“. It assumes that the backup policy ITSODBSAVE is set up and ready for execution, but that nothing has been done in terms of having tape drives, image catalogs, and so on, ready.

We deliberately set it up this way so that it does not work initially. This is eventually what may happen if you simply jump into the concept of virtual tape without understanding how it works. We thought it would be better to detail the pitfalls, rather than have you discover them. The scenarios described here are meant to educate you. You can run them on your machines to understand them better.

This chapter presents three debugging examples as a first attempt, a second attempt, and a final attempt.

## 8.1 First attempt

This debug information follows from the previously described BRMS scenario. In this case, we are trying to run a backup policy and it fails. When you are using virtual tape there still has to be a virtual tape drive that is ready, a volume mounted or at least available, and so on.

Right-click the ITSOBACK backup policy and select **Run now**, as shown in Figure 8-1, or click **Run** (this is not shown) in the upper left corner.

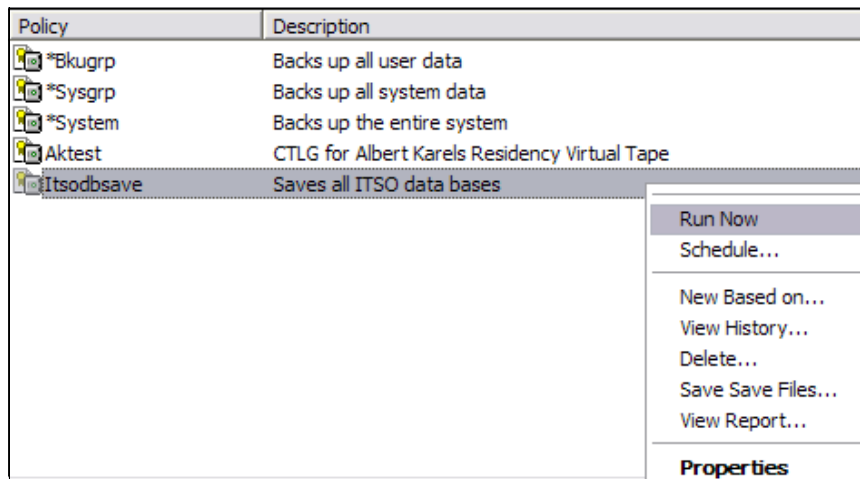

Figure 8-1 Starting a backup

5. A window appears, asking whether you want to override policy settings, as shown in Figure 8-2. Select **Use policy setting** for both the fields in the Figure, and click **OK**.

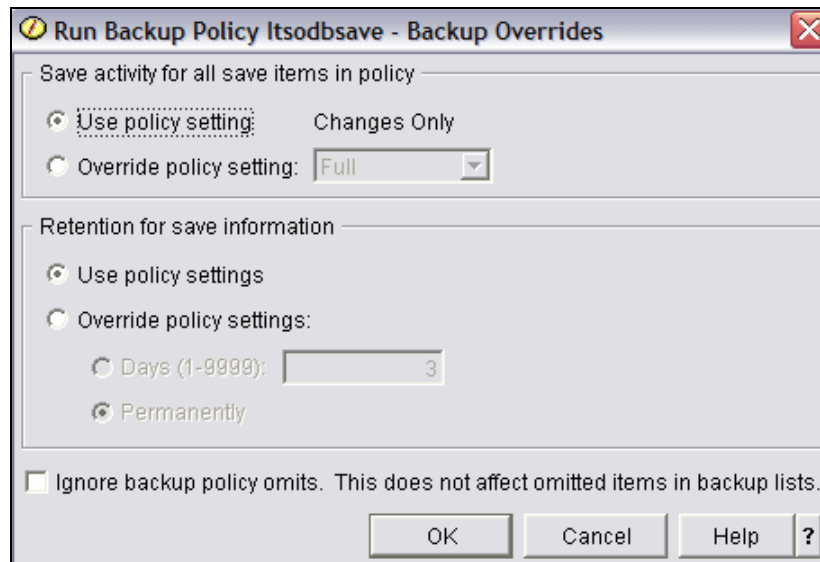

Figure 8-2 Backup overrides

To run the job, you should be connected to the central system. If you are not connected, you will be asked to do so or the Navigator will try to connect you. This could take a while.

When done, specify whether you want the joblog or not. This job is supposed to fail so that a joblog is produced. Select any of the options in the window shown in Figure 8-3 on page 434, then click **OK**.

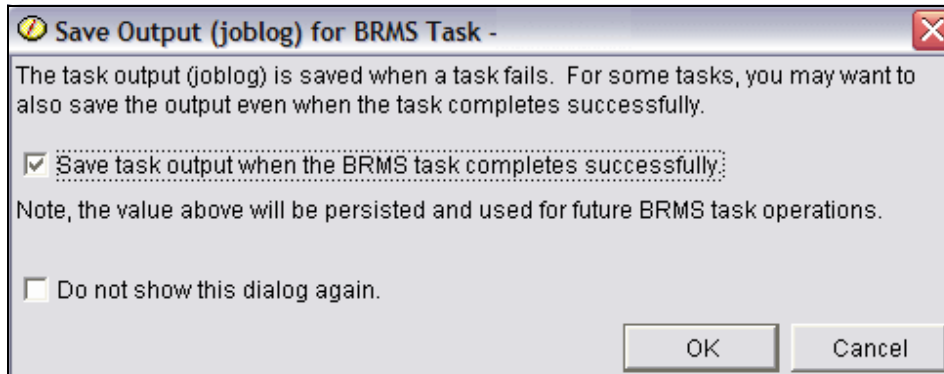

Figure 8-3 Save joblog

6. If for some reason you selected **Do not show this dialog again** in Figure 8-3, but want to get the dialog boxes again, right-click **Backup, Recovery and Media Services**, and select **Enable BRMS Dialogs**, as shown in Figure 8-4.

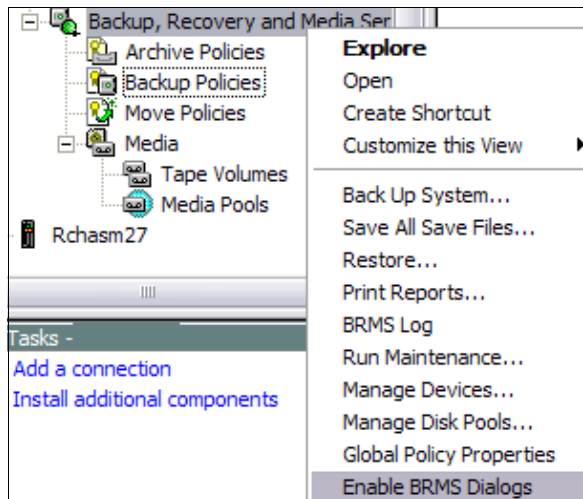

Figure 8-4 Dialog boxes

Meanwhile, the Navigator status bar shows a message indicating what is going on, as shown in Figure 8-5 on page 435.

Task 'Run 'Itsodbsave' backup policy' started.

Figure 8-5 Status bar message

Pop-up windows also appear, such as the ones shown in Figure 8-6 and Figure 8-7.

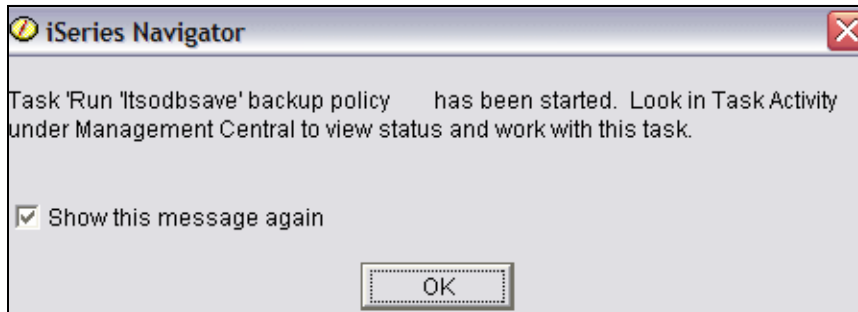

Figure 8-6 Status pop-up

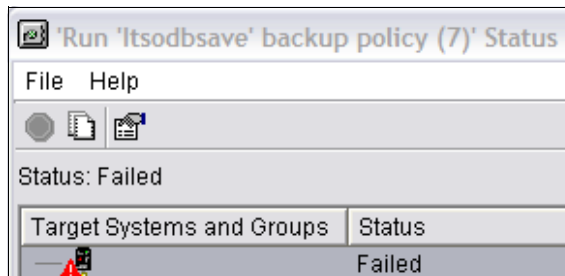

Figure 8-7 Status failed

7. Figure 8-7 shows that the job failed. To determine why, click **Task output** button, as shown in Figure 8-8.

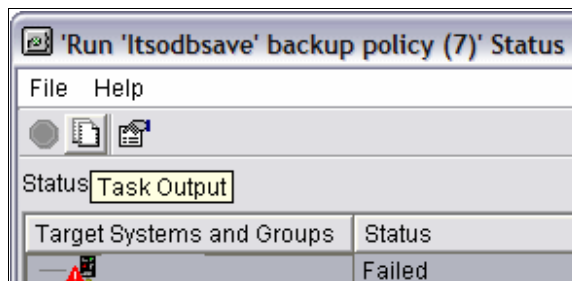

Figure 8-8 Task icon

This brings up the Viewer showing the joblog. In the Viewer, you can find the exact reason why the job failed. In this case, a BRM1034 message states that a device could not be allocated. Therefore, you should look at the device you are trying to use.

Remember that we are saving to virtual volumes, and it is no different from saving to real tape volumes. There still has to be a tape drive that is ready, a volume mounted or at least available, and so on. You should figure out how to do this when dealing with virtual volumes.

8. Scroll down the Navigator until it displays the tape devices, as shown in Figure 8-9.

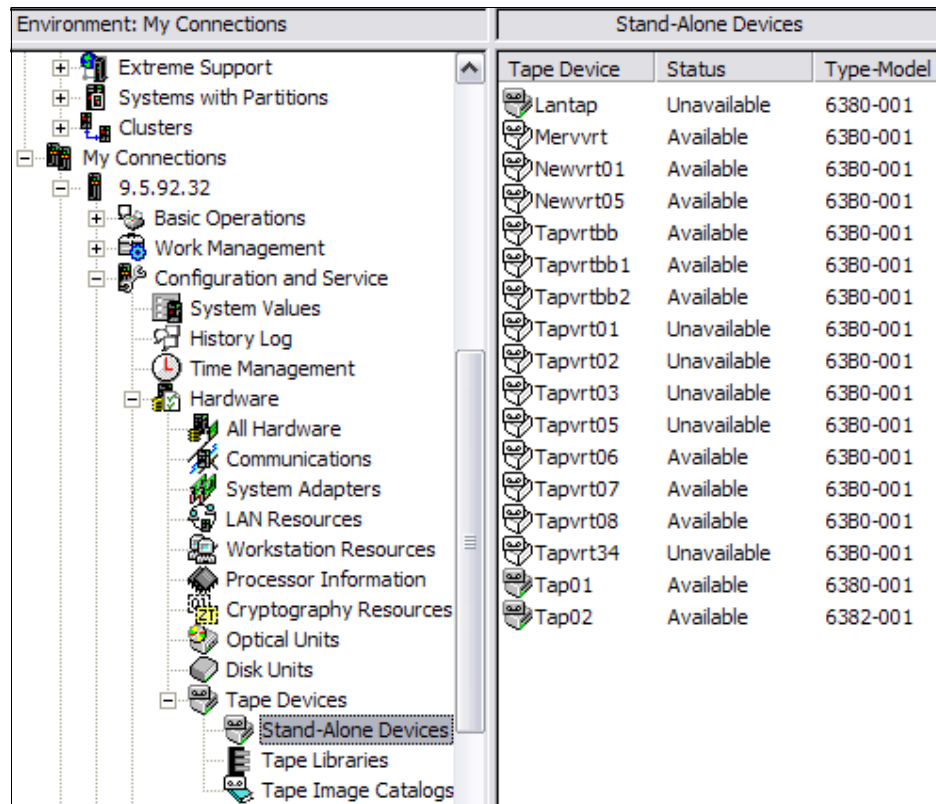

Figure 8-9 Tape devices

When you look up the tape device Tapvrt01, you will see that the status is Unavailable.

- Right-click tape device Tapvrt01 and select **Make Available**, as shown in Figure 8-10.

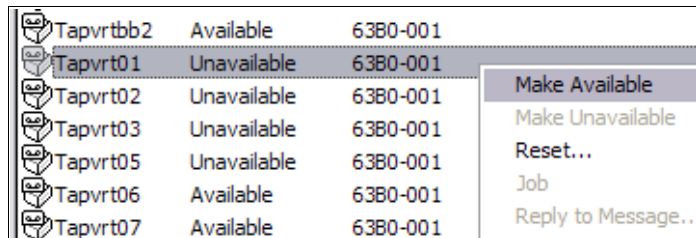

Figure 8-10 Make tape drive available

If this too fails, in the dialog box shown in Figure 8-11, select the message, and click **Details**. Click **OK**.

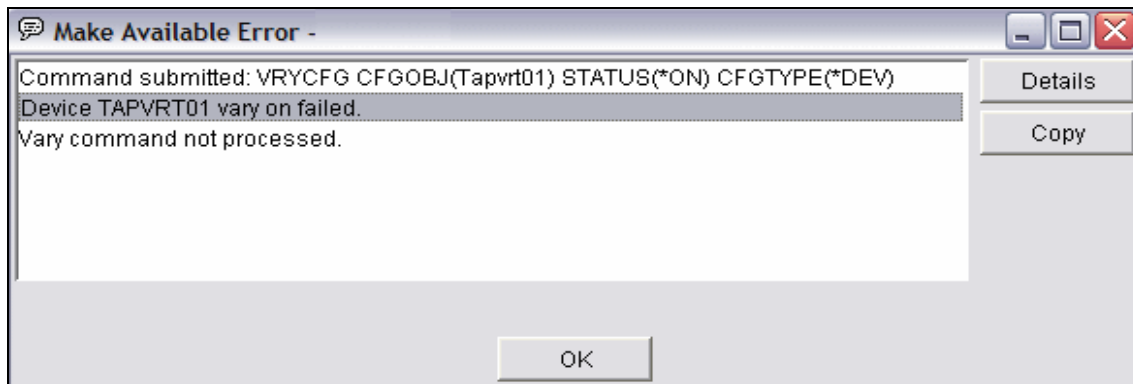

Figure 8-11 Select for detailed message

This displays a window similar to the one shown in Figure 8-12.

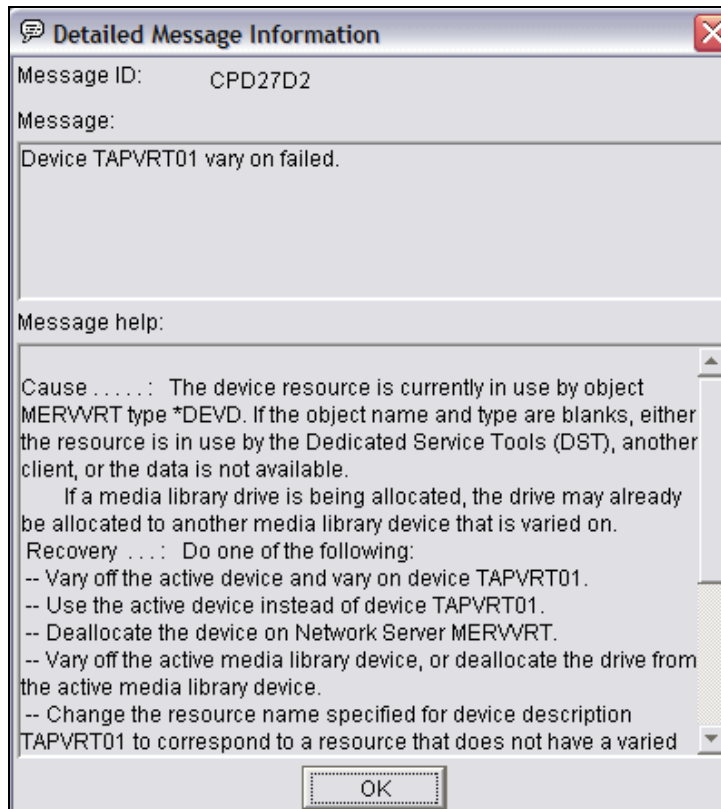

Figure 8-12 Detailed message

This window indicates that a resource is currently being used by someone else. Find out which resource is creating the problem.

Go back to the window shown in Figure 8-10 on page 437, right-click the device, and select **Properties**. A window similar to the one shown in Figure 8-13 is displayed.

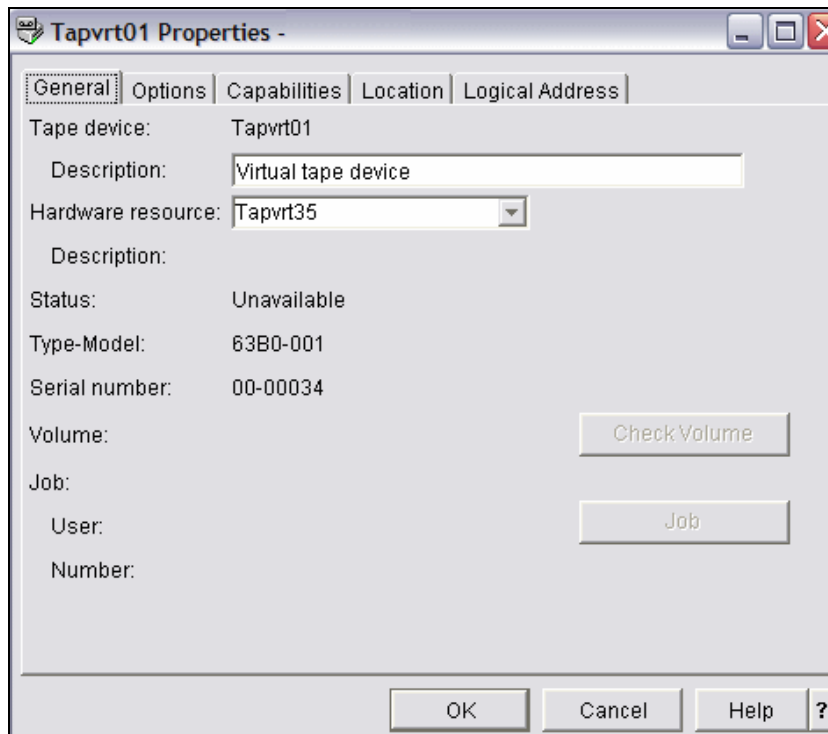

Figure 8-13 Tape drive properties

Figure 8-13 shows that the status for resource TAPVRT35 is Unavailable. This indicates it is being used by another device (Mervvrt, as shown in Figure 8-14), thus making it unavailable. Click **OK**.

10. Make the virtual tape device available, as shown in Figure 8-14, and retry the job.

Tape Device	Status	Type-Model	Job
Lantap	Unavailable	6380-001	
Mervvrt	Available	6380-001	
Newvrt01	Available	6380-001	
Newvrt05	Available	6380-001	

Figure 8-14 Make other tape drive unavailable

## 8.2 Second attempt

Launch the job the same way you did in the first attempt. This time around too, the attempt fails, as shown in Figure 8-15.

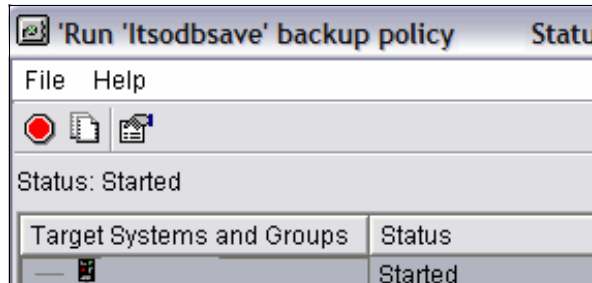

Figure 8-15 Second attempt started

Perform the same steps as you did when the first attempt failed. This time message CPF41B4 appears, showing the status of the virtual volume as Unavailable; see Figure 8-16. It also states that a virtual volume should be mounted, or at least loaded.

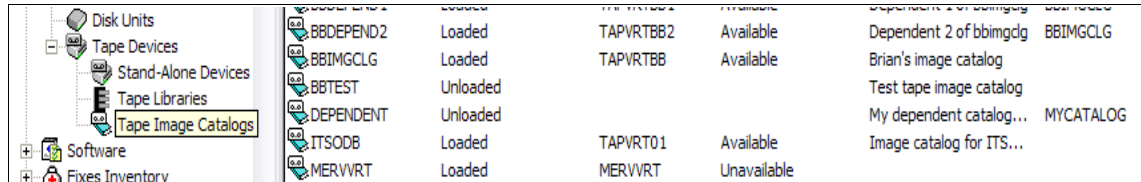

Image Catalog Name	Status	Virtual Volume	Availability	Description	Associated Virtual Volume
BBDEPEND2	Loaded	TAPVRTBB2	Available	Dependent 2 of bbimgclg	BBIMGCLG
BBIMGCLG	Loaded	TAPVRTBB	Available	Brian's image catalog	
BBTEST	Unloaded			Test tape image catalog	
DEPENDENT	Unloaded			My dependent catalog...	MYCATALOG
ITSODB	Loaded	TAPVRT01	Available	Image catalog for ITS...	
MERVVRT	Loaded	MERVVRT	Unavailable		

Figure 8-16 Tape image catalog

We recommend that you use the Work with image catalog entries (WRKIMGCLGE) command to fix it. This is a 5250 emulator command.

Since you are in the Navigator, do the following instead:

1. Right-click the image catalog and select **List Volumes**, as shown in Figure 8-17.

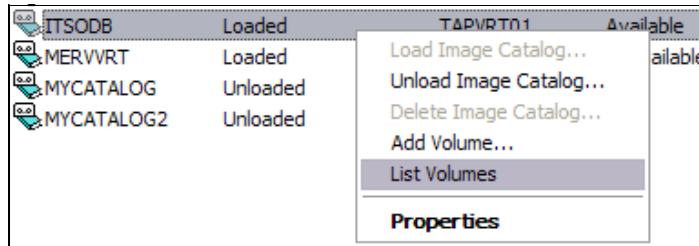

Figure 8-17 List volumes

A window similar to that displayed in Figure 8-18 appears.

Index	Volume Name	Status	Type	Density	Write Protected	Percent Used	Maximum Size
1	V32K01	Loaded	Standard labeled	*VRT32K	No	99.8	1,000
2	V32K02	Loaded	Standard labeled	*VRT32K	No	0.1	1,000
3	V32K03	Loaded	Standard labeled	*VRT32K	No	99.8	1,000
4	V32K04	Loaded	Standard labeled	*VRT32K	No	0.1	1,000
5	V32K05	Loaded	Standard labeled	*VRT32K	No	0.1	1,000
6	V32K06	Unloaded	Standard labeled	*VRT32K	No	22.0	25,000

Figure 8-18 Volumes shown

The CPF41B4 message stated that volumes should be loaded or mounted. However, Figure 8-18 shows there are several volumes that are loaded in the image catalog. Go back to read the error message once again.

It only stated that volume V32K06 is not available, but nothing was said about the volumes that were available.

So, let's first take a look at how BRMS sees a tape device.

2. Right-click **Backup, Recovery and Media Services** and select **Manage Devices**, as shown in Figure 8-19.

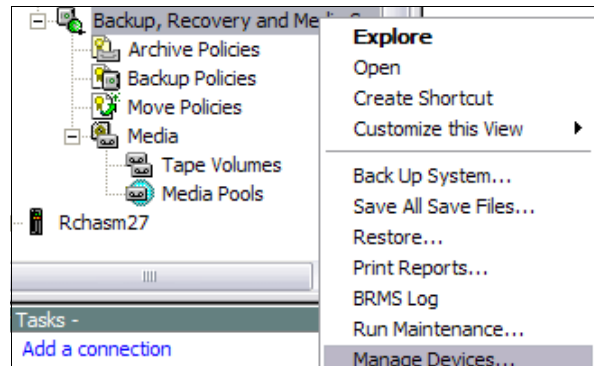

Figure 8-19 Select manage devices

This displays the window shown in Figure 8-20.

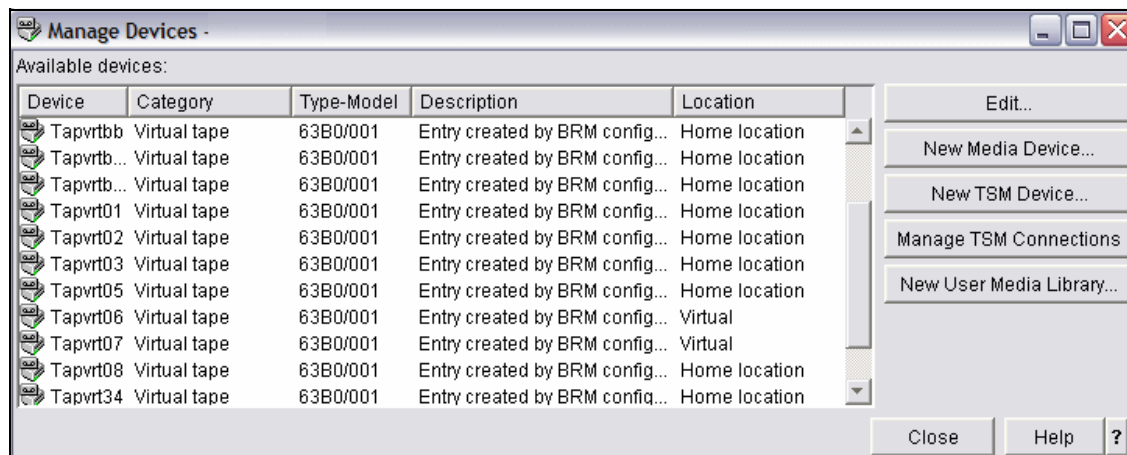

Figure 8-20 List of tape drives

What is odd in Figure 8-20 is that all the tape drives, including the one selected by you, are pointing to a location named Home location, except two drives that use location Virtual. If you recall, you placed all the volumes in location VIRTUAL, and not \*HOME.

However, the tape device is now set looking for volumes in \*HOME. Since the message explicitly named volume V32K06, take a closer look at the virtual device Tapvrt01.

3. Select **Tapvrt01** and click **Edit**. Against the General tab in the window shown in Figure 8-21, change the tape drive to the location in which you placed your virtual volumes. You have to do this although it is actually a virtual location.

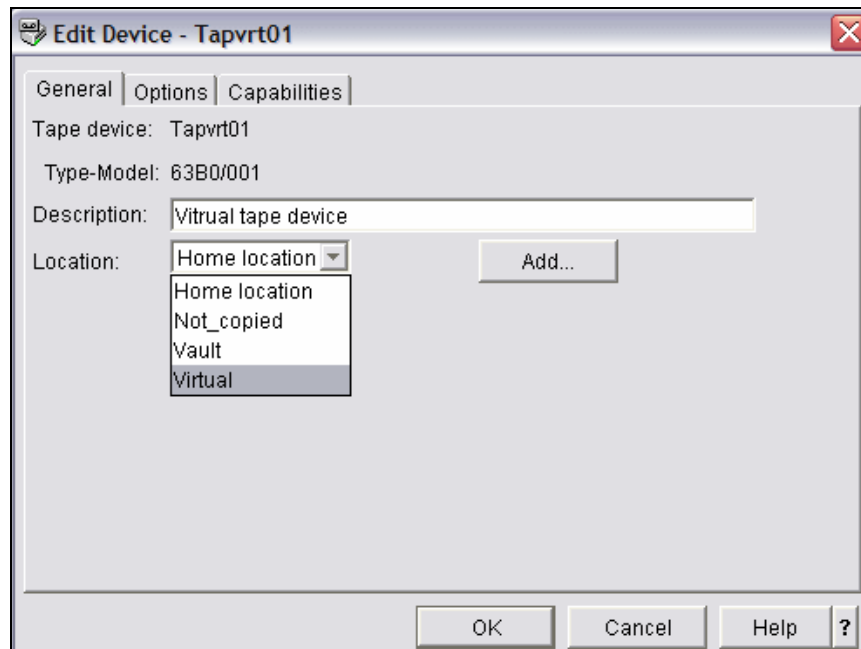

Figure 8-21 Edit tape drive to point at location

4. To determine why BRMS pinpointed volume V32K06, click **Tape Volumes** under Backup, Recovery and Media Policies (in Figure 8-19). Figure 8-22 is shown.

Volume	T...	Image Catalog	Status	Expiration	Media Pool
V32k01		Itsodb	Active		Vrt32k
V32k02		Itsodb	Expired		Vrt32k
V32k03		Itsodb	Active		Vrt32k
V32k04		Itsodb	Expired		Vrt32k
V32k05		Itsodb	Expired		Vrt32k
V32k06		Itsodb	Active	11/30/05	Vrt32k

Figure 8-22 Tape volumes list

The window shown in Figure 8-22 does *not* provide information about where the volumes are. Since all the available columns are not shown, add the column **Location** to your view, as shown in Figure 8-23.

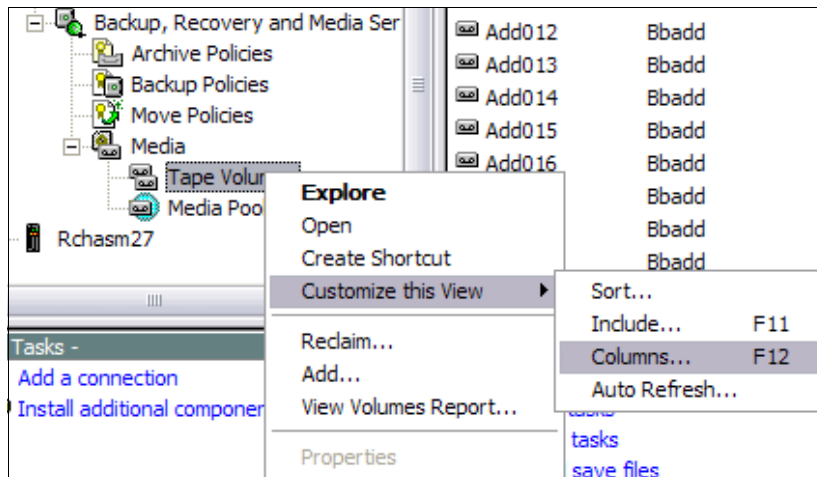

Figure 8-23 Columns to view

5. Add the column **Location** in the order in which you want it to appear, as shown in Figure 8-24. Click **OK**.

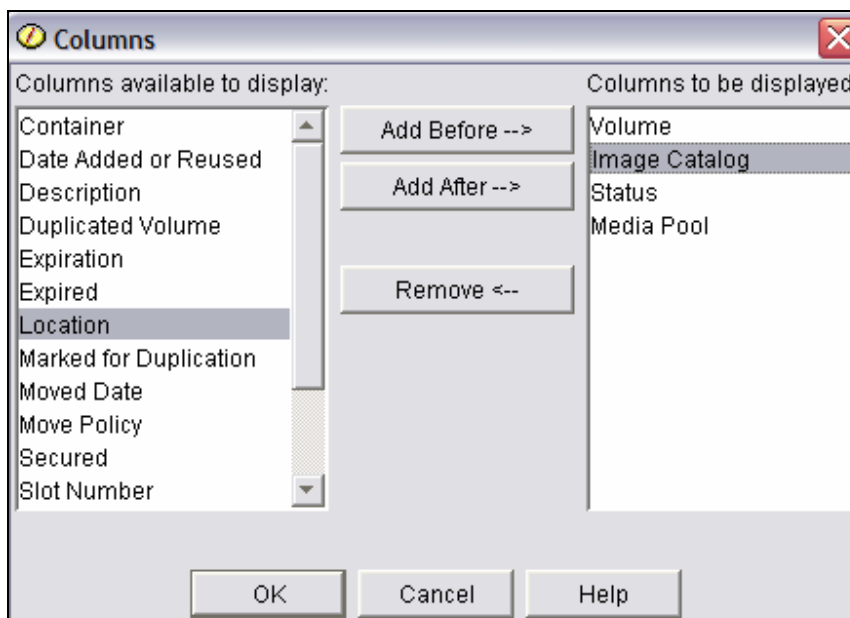

Figure 8-24 Add column

In the same window, add other columns that you will require later, such as **Marked for duplication**, **Duplicated volume**, and those you find usable. The result will be as shown in Figure 8-25.

Volume	T...	Image Catalog	Status	Expiration	Media Pool	Location
V32k01		Itsodb	Expired		Vrt32k	Virtual
V32k02		Itsodb	Expired		Vrt32k	Virtual
V32k03		Itsodb	Expired		Vrt32k	Virtual
V32k04		Itsodb	Expired		Vrt32k	Virtual
V32k05		Itsodb	Expired		Vrt32k	Virtual
V32k06		Itsodb	Expired		Vrt32k	Home location

Figure 8-25 View after adding columns

The reason why the job did not run was because BRMS was looking in a location pointed by the virtual drive \*HOME and there was only one volume, V32k06, and that volume was unavailable since somebody had played with it.

### 8.3 The final attempt

For the last time, run the example backup again, as shown in Figure 8-26.

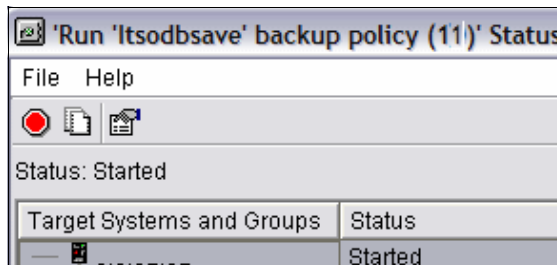

Figure 8-26 Final attempt of run backup

It appears to be running well, as shown in Figure 8-27 on page 446.

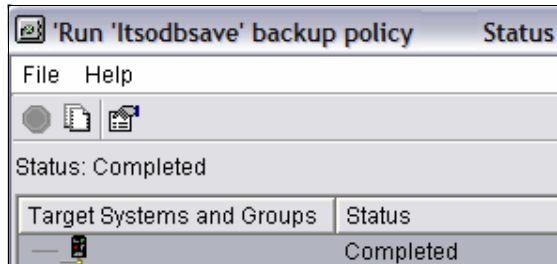

Figure 8-27 Successful run backup

While running this example backup, we want to show another pitfall you may run into.

Make sure you have eliminated the problems you ran into last time, that the tape drive is available, the correct image catalog is loaded, and there are volumes to write to, as shown in Figure 8-28.

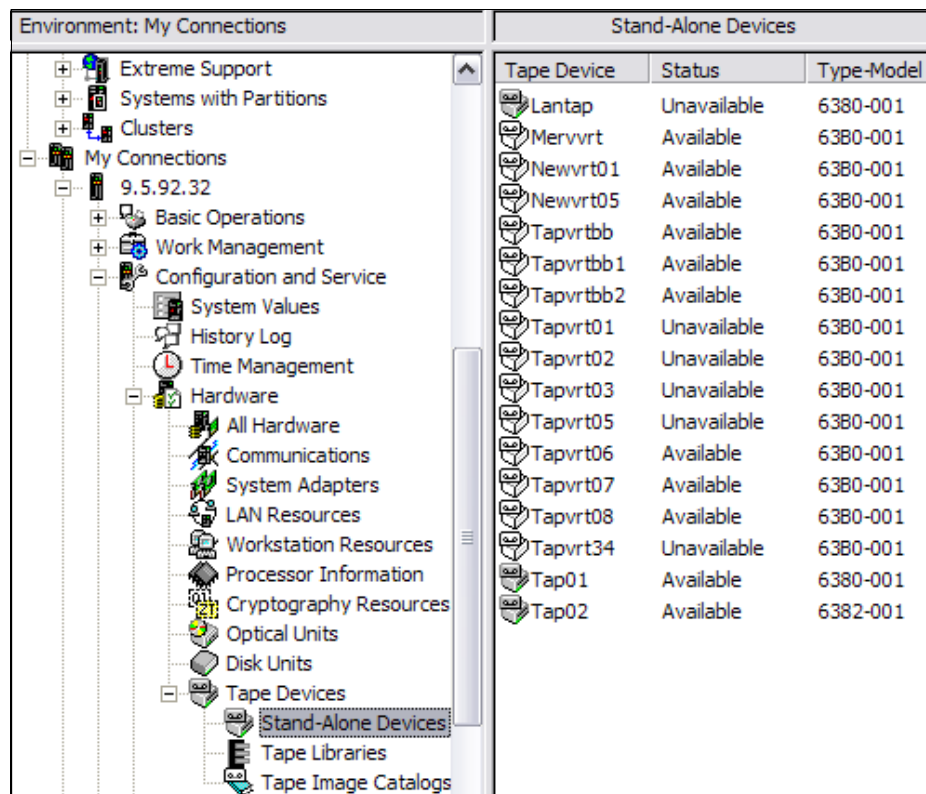

Figure 8-28 Manage tape devices

1. First, make the virtual tape drive available, as shown in Figure 8-29.

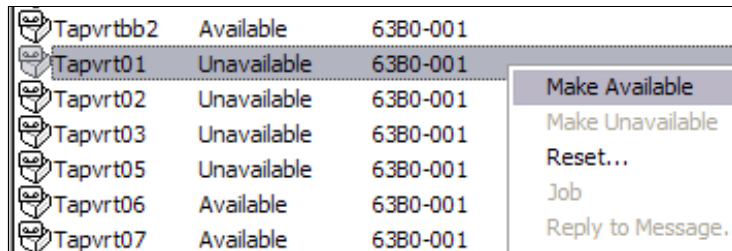

Figure 8-29 Make tape drive available

2. Ensure that the image catalog is loaded, as shown in Figure 8-30.

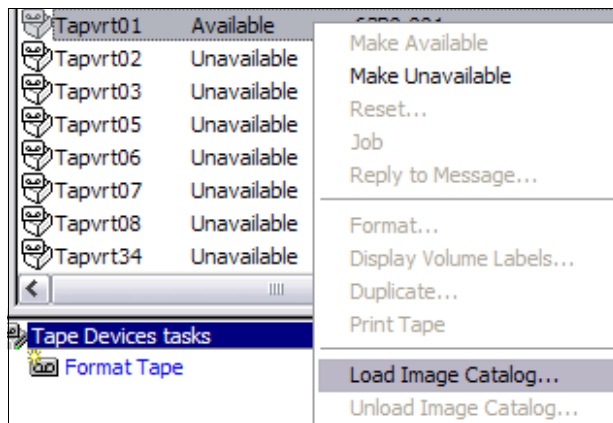

Figure 8-30 Load image catalog

3. Select the image catalog, as shown in Figure 8-31 on page 448. Click **OK**.

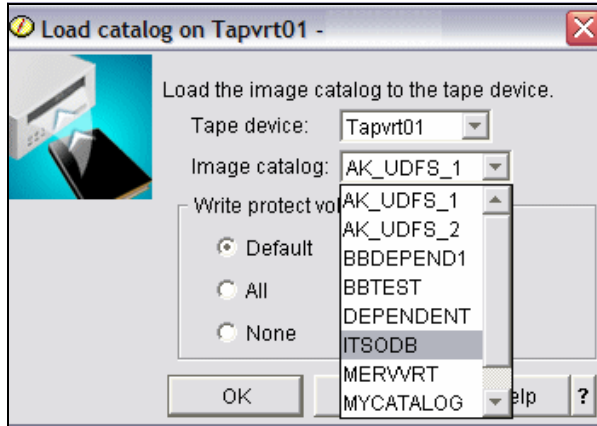

Figure 8-31 Select image catalog to load

4. Verify whether there are volumes with loaded status (by right-clicking the virtual tape drive and selecting Load Volume as shown in Figure 8-32.)

After the image catalog is loaded, more options are available. For instance, you can operate on individual tape volumes.

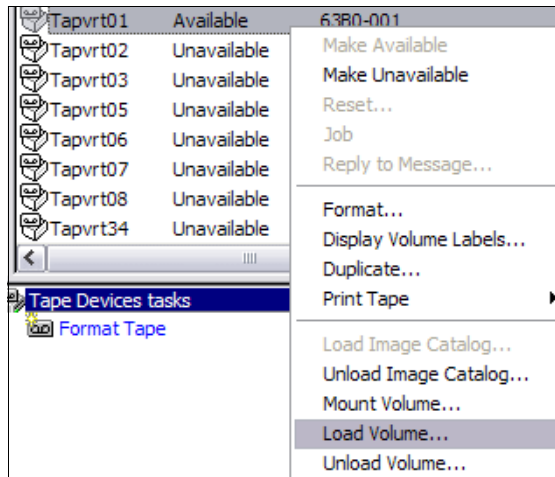

Figure 8-32 Load volume

The window that appears, shown in Figure 8-33 on page 449, does not contain all the volumes in the image catalog. Only those that can be loaded are shown. The volumes that are already in loaded status are excluded.

In this case, the following have appeared for selection:

- V32K06, because somebody else took it, as described previously.
- V32K01, because it was left in the drive from the previous backup. It has the status Mounted, which you can verify from its properties.

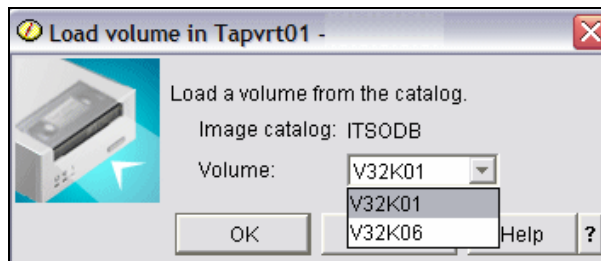

Figure 8-33 Select a volume to load

At this point, you do not have to do anything. However, if you want to mount another volume, you can do so, as shown in Figure 8-34.

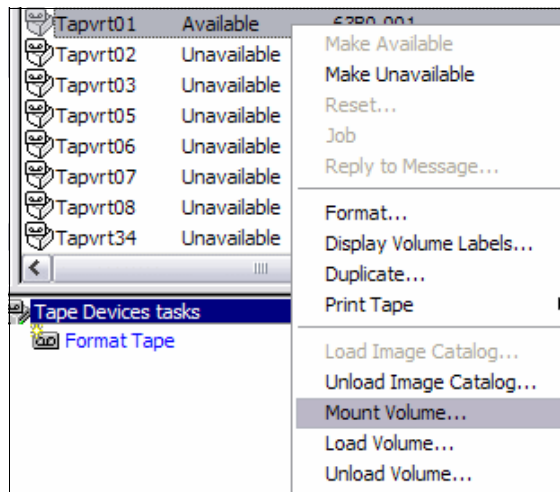

Figure 8-34 Mount volume

These operations are not related to BRMS at all. The reason they are being described is to show you how to operate in this virtual environment. For running a backup within BRMS, it is sufficient to have the volumes in loaded status. You can mount a volume if you like. However, you cannot be sure whether it will be the one written to. BRMS has its own candidate list regarding the volume it will select. Therefore, at this point, you do not have to mount anything.

However, the volume from the earlier backup is still mounted. Leave this volume as selected, and see what happens (Figure 8-35).

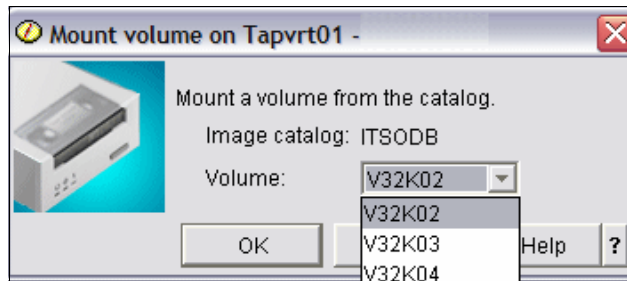

Figure 8-35 Mount a specific volume

Finally you have to check, in BRMS, which location the tape drive points at. Right-click **Media under Backup and Recovery Media Services** and select **Manage devices** (Figure 8-19 on page 442). This displays a window shown in Figure 8-36. Verify whether your drive shows location **VIRTUAL**, since, from a BRMS perspective, it is there that your tape volumes are placed.

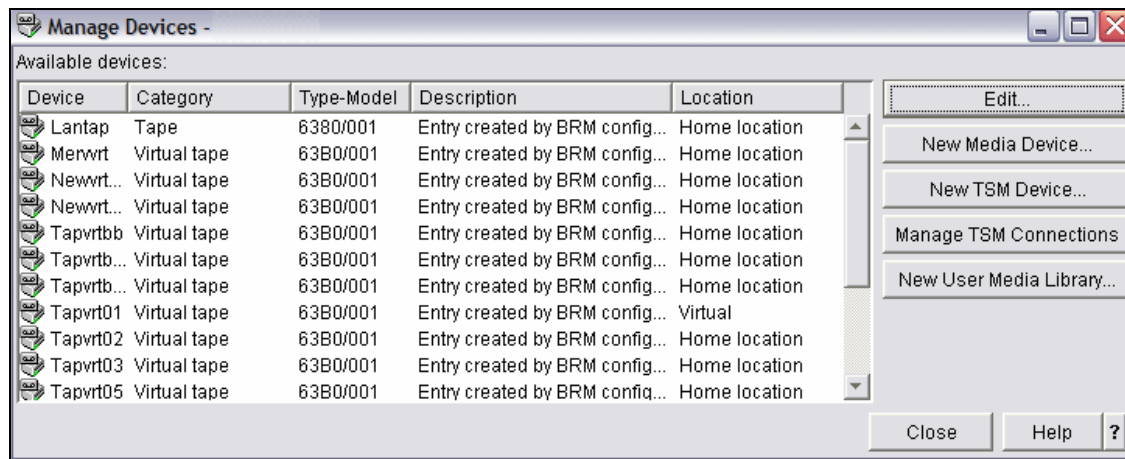

Figure 8-36 Manage devices

The goal here is to show what happens when the backup hits a volume end and continues into the next volume. To make that happen, extend what is saved.

Go to the backup policy and double-click it. Under **During** against the **What** tab, click **Add** and include a couple of more libraries. Select something from the **IFS** for a change. Ensure that it is big enough so that it does *not* fit on one volume.

When launching the backup, you can make another alteration. Create a backup policy in such a way that it will save only changes. Since the initial backup became a full backup, with BRMS converting it, this backup will be a “changes only” backup in the true sense of the word. To ensure that you fill a full tape volume, force another full backup at this point (Figure 8-37).

Since you allowed changes at runtime, you can tell it to run another full backup, although it is not required from a recovery standpoint. Your goal should be to fill more than one volume.

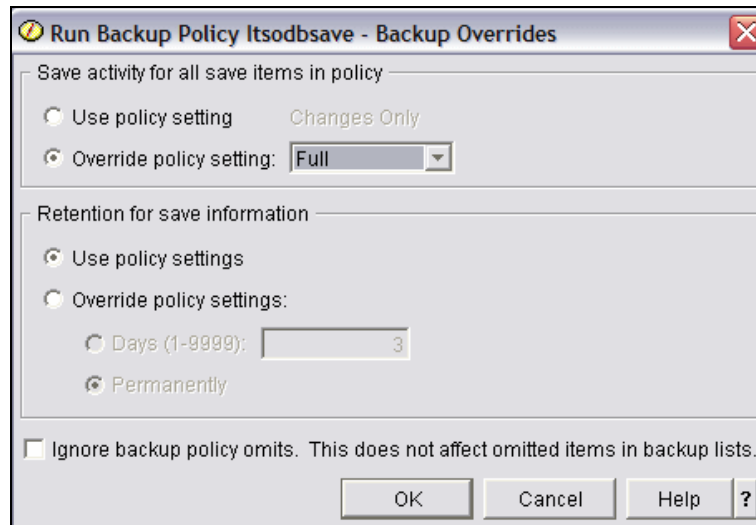

Figure 8-37 Override cumulative forcing a full backup

The job will fail after running for a while, as shown in Figure 8-38.

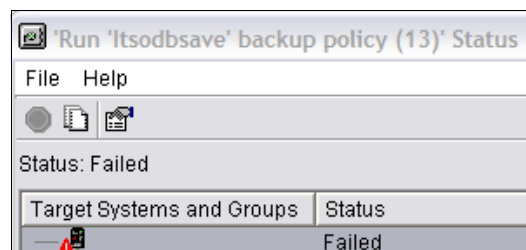

Figure 8-38 Backup job failed

The system operator’s message queue shown in Figure 8-39 on page 452 provides a clue concerning the failure.

```
No media of class VRT32K is available at location VIRTUAL. (C G)
Reply.: C
Operation ended by media management. Reason code 0003.
Some libraries not saved.
Control group ITSODBSAVE type *BKU ended abnormally.
```

*Figure 8-39 No media available*

The job failed since there was no media (volumes) available for your media class in location VIRTUAL. Check the joblog shown in Figure 8-40 for more details.

```
Starting save of library DBITS0* to devices TAPVRT01.
Volume V32K03 on device TAPVRT01 is density *VRT32K.
13686 blocks processed for sequence 1, volume V32K03, on device TAPVRT01.
13231 blocks processed for sequence 2, volume V32K03, on device TAPVRT01.
12591 blocks processed for sequence 3, volume V32K04, on device TAPVRT01.
End of volume detected for file QSYSTAP in QSYS.
The next volume inserted on device TAPVRT01 has volume identifier V32K04.
Operation ended by media management. Reason code 0003.
0003 = The user entered a cancel reply for a media mount message.
24 objects saved from library DBITSODATA.
Some libraries not saved.
Save or restore operation ended unsuccessfully.
```

*Figure 8-40 Backup job failed joblog*

However, this too is unclear about why the job failed. To determine the cause of the failure, you need to understand how BRMS operates.

BRMS is an application. The i5 concept, all the way back to the System/38™, is single-level storage, a layered structure that shields the programs from the platform they run on, and is truly portable from release to release. As is the case with any other i5 application, BRMS requests that things be executed using the i5 operating system. The only goal of BRMS is to have data backed up and to keep track of it.

BRMS achieves this goal by using a set of policies. It has a number of databases where all this information is stored. Any other operation, such as saving, restoring data, initializing tape volumes, and so on, is done by the operating system on request from BRMS.

The operating system can handle three types of tape devices:

- ▶ Direct or fiber attached, including virtual, such as:
  - Single drives
  - Tape libraries
- ▶ Remote drives such as Tivoli Storage Management servers

In most cases, in order to do something using a single device, you require an operator. Tape libraries, on the other hand, carry out all these operations by themselves—but they require some kind of command telling them what to do.

So for tape libraries, the data flows directly to the tape drive selected by the library manager function. The commands that tell the library what volume to mount and so on, go to the library manager function. Tape libraries are of different brands and are constructed a bit differently. Although the details of that topic is beyond the scope of this chapter, it is important to understand the logic behind tape libraries.

In a tape library environment, the operating system does not have control over the individual tape drives in the tape library. They are varied off. It is the library itself that picks up a suitable drive for you, depending on your needs. The operating system only “speaks” to a library manager function and when contact to the drive (that is, the library manager function selected) is established, the data is sent directly to the tape drive. Any command to a library must contain at least two things: what to do, and which volume to operate upon.

Before discussing single drives, you should understand TSM. From the BRMS standpoint, TSM is simply a tape device sitting in the net. BRMS saves to temporary save files. It inserts an identification tag, chops the save file into pieces, and sends them to a network address, which in fact is the TSM server. When done, BRMS only stores these identification tags so that it can request the data back.

What actually happens to the data in the TSM server is up to TSM to handle. TSM either handles the data by using its own policies, or BRMS tells it which policies to use (or supplies policies).

**Note:** An IBM @server iSeries can be a TSM server itself using the QShell environment, but the concept remains the same.

Our backup scenario uses a virtual tape device which is seen as single tape unit, and not a tape library. If set up properly, a tape library can handle its volume the way it wants to. Normally, a single drive cannot do this. It requires a manual operation when, for instance, it comes to mounting the next tape. In a virtual environment like this, there is no way of doing this, nor is there a need for it since

everything is virtual. However, someone has to take care of the next volume mount message that comes from the tape drive end of volume indication.

The operating system checks it to see if it can handle the situation. If not, it passes the message to the application running the job. How BRMS handles that exception is defined in its own tape device descriptions, that is, those that were created when running INZBRM \*DEVICE.

Perform the following tasks:

1. Bring up manage devices and click **Edit...**, as shown in Figure 8-41.

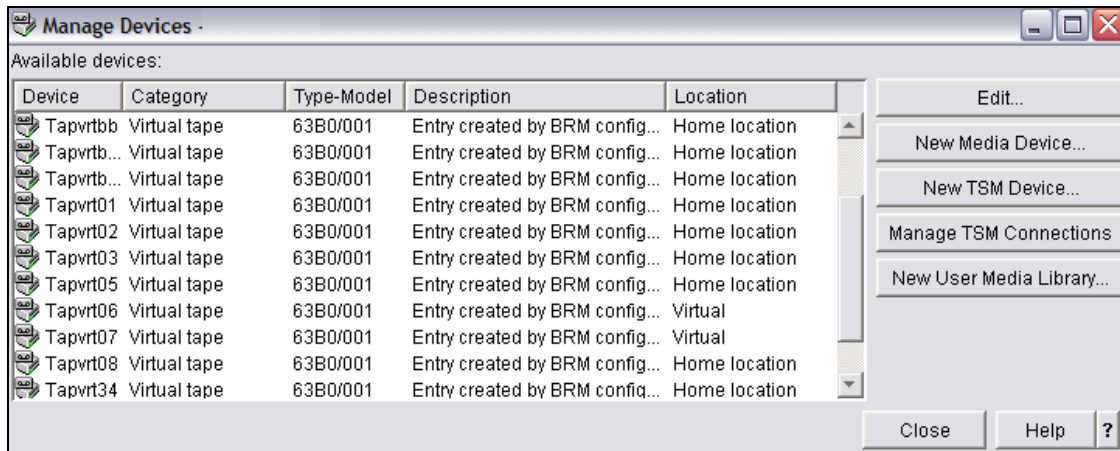

Figure 8-41 List of tape drives

In the window that appears, under the tab Options, you see a field Send message when ready for next volume; see in Figure 8-42 on page 455. If this option is selected, it means that an operator has to mount the next volume and

reply to the message. In a virtual environment, since this makes no sense, the operation is cancelled and the job is completed after the first volume is filled.

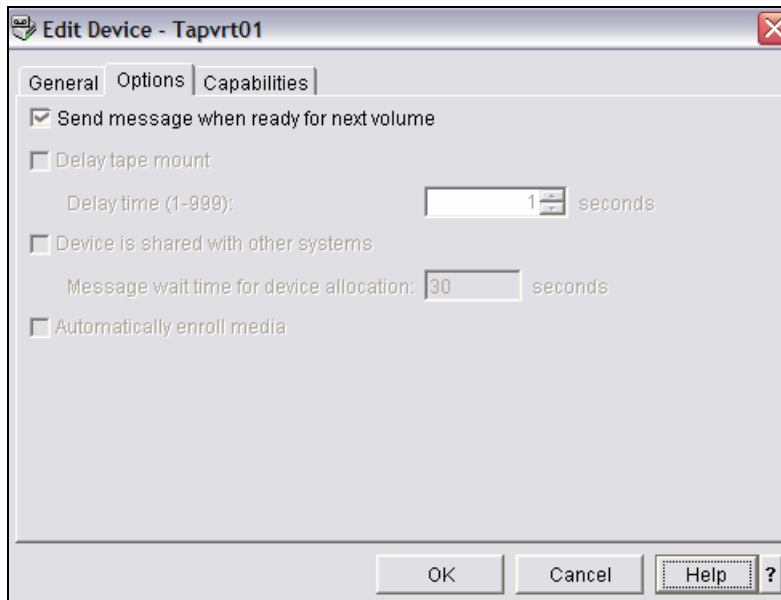
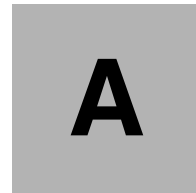

Figure 8-42 Message handling

Fortunately, when working from Navigator, you will not see this problem. It is taken care of automatically.





## **Block sizes**

## Block size chart

Table A-1 shows the tape drive types, highest supported density, block size, and whether the tape drives are capable of using optimum blocking.

Table A-1 Details about tape drive types

Type	Highest density	Block size	Optimum blocking
3480	*FMT3480	64 K	No
3490E	*FMT3490E	256 K	Yes
3490F - 18 track	*FMT3480	64 K	Yes
3490F - 36 track	*FMT3490E	256 K	Yes
3570-Bxx	*FMT3570	256 K	Yes
3570-Cxx	*FMT3570E	256 K	Yes
3580-001	*ULTRIUM1	256 K	Yes
3580-002	*ULTRIUM2	256 K	Yes
3580-003	*ULTRIUM3	256 K	Yes
3590-Bxx	*FMT3590	256 K	Yes
3590-Exx	*FMT3590E	256 K	Yes
3590-Hxx	*FMT3590H	256 K	Yes
3592-J1A	*FMT3592A1	256 K	Yes
4685-001	*VXA2	240 K	Yes
6335	*QIC3040	32 K	No
6341	*QIC120	32 K	No
6342	*QIC525	32 K	No
6343	*QIC1000	32 K	No
6344	*QIC2GB	32 K	No
6346	*QIC120	32 K	No
6347	*QIC525	32 K	No
6348	*QIC1000	32 K	No
6349	*QIC2GB	32 K	No

6366	*QIC120	32 K	No
6368	*QIC1000	32 K	No
6369	*QIC2GB	32 K	No
6378	*QIC525	32 K	No
6379	*QIC1000	32 K	No
6380	*QIC2GB	32 K	No
6381	*QIC2DC	32 K	No
6382	*QIC4DC	32 K	No
6383	*QIC5010	32 K	No
6384	*SLR60	256 K	Yes
6385	*QIC5010	32 K	No
6386	*MLR3	256 K	Yes
6387	*SLR100	256 K	Yes
6390	*FMT7GB	240 K	No
63B0 - virtual	*VRT256K	256 K	Yes
7207-122	*QIC4DC	32 K	No
7207-330			
7208-002	*FMT2GB	240 K	No
7208-012	*FMT5GB	240 K	No
7208-222	*FMT7GB	240 K	No
7208-342	*FMT20GB	240 K	Yes
7208-345	*FMT60GB	240 K	Yes
9346	*QIC120	32 K	No
9348	6250	32 K	No





# B

## Sample command language

BRMS allows the addition of only one virtual volume at a time using the ADDMEDBRM command, as discussed in Chapter 6, “BRMS and virtual tape” on page 279 and Chapter 7, “BRMS and virtual tape working from the Navigator” on page 329.

However, if you have to add many virtual volumes in BRMS, write a program that adds volumes automatically into BRMS.

The material in this appendix has not been submitted to any formal IBM test and is published *as is*. It has not been subject to rigorous review. Your feedback is welcome to improve the usefulness of the material.

IBM assumes no responsibility for the accuracy or completeness of the information presented in this book. The use of this information or the implementation of any of these techniques is a client responsibility and depends on the client’s ability to evaluate and integrate them into the operational environment

## How command language program works

The intention of the command language (CL) program is to add multiple virtual volumes to BRMS with one command. Since the virtual volumes in BRMS are based on the virtual volumes in the image catalog, and the image catalog volumes should exist before adding a volume to BRMS, the sample source also creates the virtual volumes in the image catalog.

If a virtual volume with the same name already exists in the image catalog, it will be ignored and the program will proceed with the next volume. However, the existing volume mentioned will be added to BRMS if it is not in the BRMS media inventory.

It also assumes that the virtual tape device is varied on.

## Command language sample source

The CL source shown in Example B-1 is just an example of how to do this in CL. This CL source must be used in conjunction with the command source listed in Example B-2 on page 466.

*Example: B-1 Sample CL source for adding multiple volumes to BRMS*

---

```

/*****
/*   Please use this CL source only in conjunction with   */
/*   the Command source listed on next page.             */
/*                                                       */
/*   The intention of this program is to automate adding */
/*   volumes to the image catalog AND BRMS. Remember that */
/*   BRMS allows only adding 1 volume at a time.         */
/*                                                       */
/*   Not all parameters are covered for adding virtual  */
/*   volumes to the image catalog and BRMS.             */
/*                                                       */
*****/

/***** Parameter list *****/
PGM PARM(&ImgClg    +
        &TapDev     +
        &MaxVol     +
        &Prefix     +
        &VrtClass   +
        &Location   +
        &Init       +
        &Code)
```

```

/***** Declare variables *****/
/* Total of volumes to add */
DCL VAR(&MaxVol) TYPE(*DEC) LEN(3 0)

/* Volume sequence number to be added */
DCL VAR(&VolNbr) TYPE(*DEC) LEN(3 0)

/* Only used internally in this source for */
/* casting decimal to char */
DCL VAR(&VolNbrChar) TYPE(*CHAR) LEN(3)

/* Volume name will be a combination of Prefix */
/* and volume sequence number (VolNbr) */
DCL VAR(&Volume) TYPE(*CHAR) LEN(6)

/* First 3 chars of volume */
DCL VAR(&Prefix) TYPE(*CHAR) LEN(3)

/* Media Class to be used in BRMS */
DCL VAR(&VrtClass) TYPE(*CHAR) LEN(7)

/* Init volume when ADDMEDBRM*/
DCL VAR(&Init) TYPE(*CHAR) LEN(4)

/* Image catalog name */
DCL VAR(&ImgClg) TYPE(*CHAR) LEN(10)

/* Virtual tape device name */
DCL VAR(&TapDev) TYPE(*CHAR) LEN(10)

/* Virtual tape device name */
DCL VAR(&TapDevSts) TYPE(*DEC) LEN(5 0)

/* BRMS location */
DCL VAR(&Location) Type(*CHAR) LEN(10)

/* Label vol ASCII or EBCDIC */
DCL VAR(&Code) TYPE(*CHAR) LEN(7)

/* Density is determined by &VrtClass and is */
/* used for the image catalog */
DCL VAR(&Density) TYPE(*CHAR) LEN(8)

/* Reflect volume name in text in BRMS */
DCL VAR(&VolText) TYPE(*CHAR) LEN(20) +
VALUE(X'00')

/* Error Text */
DCL VAR(&ErrorText) TYPE(*CHAR) LEN(50) +

```

```

VALUE(X'00')

/* Code start *****/

/* Checking existence of Image catalog object */
/* If not, prepare error text and leave the program */
CHKOBJ OBJ(QUSRSYS/&ImgClg) OBJTYPE(*IMGCLG)
MONMSG MSGID(CPF9801) +
EXEC(DO) /*Object not found */
CHGVAR VAR(&ErrorText) VALUE('Specified Image Catalog' +
*BCAT &ImgClg *BCAT 'does not exist.')
GOTO CMDLBL(ERR_MSG)
ENDDO

/* Checking existence of Virtual Tape Device */
/* If not, prepare error text and leave the program */
CHKOBJ OBJ(QSYS/&TapDev) OBJTYPE(*DEV)
MONMSG MSGID(CPF9801) +
EXEC(DO) /*Object not found */
CHGVAR VAR(&ErrorText) VALUE('Specified Tape Device' +
*BCAT &TapDev *BCAT 'does not exist.')
GOTO CMDLBL(ERR_MSG)
ENDDO

/* Check status of Virtual Tape Device and vary on if it is varied off */
/* If vary on is not possible, then prepare error text and leave program*/
RTVCFGSTS CFGD(&TapDev) CFGTYPE(*DEV) STSCDE(&TapDevSts)
IF COND(&TapDevSts *EQ 0) +
THEN(DO) /* Virtual Tape device varied off */
VRYCFG CFGOBJ(&TAPDEV) CFGTYPE(*DEV) STATUS(*ON)
MONMSG MSGID(CPF0000)
DLYJOB DLY(1)
RTVCFGSTS CFGD(&TapDev) CFGTYPE(*DEV) STSCDE(&TapDevSts)
ENDDO
IF COND(&TapDevSts *NE 30) +
THEN(DO)
CHGVAR VAR(&ErrorText) VALUE('Unable to vary on' +
*BCAT &TapDev *BCAT '.')
GOTO CMDLBL(ERR_MSG)
ENDDO

NxtVol: CHGVAR VAR(&VolNbr) VALUE(&VolNbr + 1)
CHGVAR VAR(&VolNbrChar) VALUE(&VolNbr)
CHGVAR VAR(&Volume) VALUE(&Prefix *TCAT &VolNbrChar)
CHGVAR VAR(&Density) VALUE('*' *TCAT &VrtClass)
CHGVAR VAR(&VolText) VALUE('Virtual Volume' *TCAT &VolNbrChar)

```

```

/* Add volume to Image catalog */
/* Before associating a virtual device with the image */
/* catalog (LODIMGCLG) at least 1 volume must be in the catalog */
  ADDIMGCLGE IMGCLG(&ImgClg) FROMFILE(*NEW)      +
    TOFILE(&Volume) VOLNAM(&Volume)           +
    DENSITY(&Density) CODE(&Code)

/* Catch messages */
  MONMSG MSGID(CPF0000)

/* Load of image catalog needs only to be done once, */
/* but it is required for BRMS. You cannot add a volume */
/* to BRMS when the image catalog isn't loaded. */
  IF COND(&VolNbr *EQ 1)      +
    THEN(DO)

/* Now load image catalog */
  LODIMGCLG IMGCLG(&ImgClg) DEV(&TapDev)

/* Catch messages */
  MONMSG MSGID(CPF0000)
  ENDDO

/* Add volume to BRMS */
  ADDMEDBRM VOL(&Volume) MEDCLS(&VrtClass) INZ(&Init) +
    IMGCLG(&ImgClg) DEV(&TapDev)      +
    LOC(&Location)                    +
    CHECK(*YES) CODE(&Code)           +
    TEXT(&VolText)

/* Catch messages */
  MONMSG MSGID(CPF0000)

/* Add next volume if total amount of volume isn't */
/* reached yet. */
  IF COND(&VolNbr *LT &MaxVol)      +
    THEN(GOTO CMDLBL(NxtVol))

  GOTO CMDLBL(END_PGM)

NO_TAPDEV:/* Specified Tape Device does not exist */
  SNDPGMMSG MSG('Specified Tape Device' *BCAT &TapDev +

```

```
*BCAT 'does not exist.')
```

```
ERR_MSG: /* Send error message */  
         SNDPGMMSG MSG(&ErrorText)
```

```
END_PGM: /* Program end */  
        ENDPGM
```

---

## Command source to use with the command language

To make it easier to use the CL source and to prevent the most common user errors, the command source shown in Example B-2 should be used in conjunction with the CL source.

*Example: B-2 Command source to use in conjunction with the CL*

---

```
/*  
*****  
/* Please use this command source in conjunction with */  
/* the previous listed CL. */  
*****  
*/  
  
        CMD          PROMPT('Add virtual volumes to BRMS')  
  
/* First parameter is Image catalog name */  
/* No check is included for a valid Image catalog name */  
        PARM          KWD(IMGCLG) TYPE(*CHAR) LEN(10) MIN(1)      +  
                      INLPMTLEN(10) PROMPT('Name of Image Catalog')  
  
/* Specify your Virtual tape drive here */  
/* No Check is included for a valid Virtual tape device name*/  
        PARM          KWD(TAPDEV) TYPE(*CHAR) LEN(10) RSTD(*NO)    +  
                      MIN(1) VARY(*NO) PROMPT('Tape Device')  
  
/* A Maximum of 256 virtual volumes can be added to 1 image catalog */  
        PARM          KWD(MAXVOL) TYPE(*DEC) LEN(3) RSTD(*NO)      +  
                      DFT(1) RANGE(1 256) PROMPT('Amount of +  
                      volumes to add')  
  
/* The prefix represents the first 3 characters of the volume name */  
        PARM          KWD(PRFX) TYPE(*CHAR) LEN(3) DFT(VRT)        +  
                      FULL(*YES) PROMPT('Volume Prefix')  
  
/* The listed values below are used for the density (blocksize) */  
/* of the image catalog entry and also for the BRMS media class. */  
/* Within BRMS you can create your own media class name, however */
```

```

/* the CL and command source listed here do not cover this.          */
    PARM      KWD(VRTCLS) TYPE(*CHAR) LEN(7) RSTD(*YES)      +
              DFT(VRT256K) VALUES(VRT32K VRT64K VRT240K    +
              VRT256K) DSPINPUT(*PROMPT)                    +
              CHOICE(*VALUES) PROMPT('Specify Media Class')

/* The location will be used within BRMS                             */
/* There is no check if the name is valid.                           */
    PARM      KWD(LOC) TYPE(*CHAR) LEN(10) DFT(*HOME)        +
              PROMPT('Location of Volume within BRMS')

/* Init is used to specify if the volume should be initialized      */
/* or not when adding the volume to BRMS.                            */
    PARM      KWD(INIT) TYPE(*CHAR) LEN(4) RSTD(*YES)        +
              DFT(*YES) VALUES(*YES *NO) VARY(*NO)         +
              PROMPT('Initialize tape')

/* Label volume in EBCDIC or ASCII                                   */
    PARM      KWD(CODE) TYPE(*CHAR) LEN(7) RSTD(*YES)        +
              DFT(*EBCDIC) VALUES(*EBCDIC *ASCII)          +
              VARY(*NO) PROMPT('Code')

```

---

## Command options

At the command prompt, specify the following options:

- ▶ Name of image catalog (IMGCLG)

This is the name of the image catalog you want to use. The image catalog should already exist and does not have to be loaded. After the command is issued and the volumes are added to the image catalog and BRMS, the image catalog is loaded and associated with the tape device specified.

- ▶ Tape device (TAPDEV)

This is the name of the virtual tape device you want to use with the image catalog.

- ▶ Amount of volumes to add (MAXVOL)

This is the total number of volumes to be added. Possible values vary from 1 to 256, with 256 being the maximum number of volumes per image catalog.

- ▶ Volume prefix (PRFX)

This is composed of the first three characters to be used in the volume name. The default value is VRT, which if not changed will result in VRT001, VRT002, VRT003, and so on.

Special characters are not allowed for image catalog volume names, but the program or command does not check this.

**Note:** Ensure that the volume name you want to add to BRMS does *not* exist on any system in a BRMS network.

▶ Specify media class (VRTCLS)

Specify the BRMS media class name here for the virtual media to be added. There are four different BRMS media class names you can use here: VRT256K, VRT240K, VRT64K, and VRT32K. No other values are allowed in this sample source. Therefore, if you created your own media classes within BRMS, you cannot specify them here.

This parameter is also used for determining the tape density parameter, which has to be specified in the ADDIMGCLGE command.

▶ Location of volume within BRMS (LOC)

If not specified, the default location of the virtual volumes within BRMS will be \*HOME. However, you can specify other locations or the location name you created.

▶ Initialize tape (INIT)

This parameter, too, is used only within BRMS. Therefore, when adding the virtual volume to BRMS, initialize it. The default is \*YES and possible values are \*YES and \*NO.

▶ Code (CODE)

This specifies whether the tape label is written in ASCII or EBCDIC. This is used for the tape volumes in the image catalog and within BRMS. Possible values are \*ASCII and \*EBCDIC.

Figure B-1 on page 469 shows an example of the prompt screen when adding the virtual volumes to BRMS using the sample program.

```

Add virtual volumes to BRMS (ADDVRTVOL)

Type choices, press Enter.

Name of Image Catalog . . . . . CATALOG01   Character value
Tape Device . . . . . TAPVRT01   Character value
Amount of volumes to add . . . . . 20       1-256
Volume Prefix . . . . . VRT       Character value
Specify Media Class . . . . . VRT256K    VRT32K, VRT64K, VRT240K...
Location of Volume within BRMS   VIRTUAL   Character value
Initialize tape . . . . . *YES       *YES, *NO
Code . . . . . *EBCDIC           *EBCDIC, *ASCII

```

*Figure B-1 Example of adding multiple virtual volumes to BRMS*



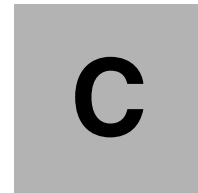

## Quick start guide

In this appendix we provide information that will help you use virtual tape quickly.

Note that we list only the most basic commands and steps here; we do not detail parameters, limitations, or important considerations. For more details about those topics, refer to the applicable chapters in this redbook.

## Setting up virtual tape

We describe the basic steps and commands for setting up virtual tape here. The first section lists the steps using IBM @server iSeries Navigator. The following section lists the commands for 5250 emulation users.

### Setting up virtual tape through iSeries Navigator

Here are the basic steps involved in setting up virtual tape through iSeries Navigator:

1. Create or change to a virtual tape device.

Currently, virtual tape devices cannot be created through IBM @server iSeries Navigator. However, an existing device description can be changed to use a virtual resource, or you can create a virtual tape device from a 5250 emulation session.

- Change existing device.
  - i. Select **Configuration and Services** → **Hardware** → **Tape Devices** → **Stand-alone Devices**.
  - ii. Make sure the physical tape device's status is **Unavailable**. If it is not, right-click the device and select **Make Unavailable**.
  - iii. Right-click the existing tape device and click **Properties**.
  - iv. Change the hardware resource parameter to **Generate virtual resource** and click **OK**.

- Use the following command to create through the command line:

```
CRTDEVTAP DEVD(TAPVRT01) RSRNAME(*VRT)
```

2. Vary on the virtual tape device.

- a. Select **Configuration and Services** → **Hardware** → **Tape Devices** → **Stand-Alone Devices**.
- b. Right-click the device (for example, **TAPVRT01**) in the right window pane, and select **Make Available**.

3. Create a virtual tape image catalog.

- a. Select **Configuration and Service** → **Hardware** → **Tape Devices**.
- b. Right-click **Tape Image Catalogs**.
- c. Select **Create Image Catalog**.
  - Enter the Catalog name (for example, Backup).
  - Enter the Directory path (for example, /images/tape/backup).
- d. Click **OK**.

4. Create virtual images in the image catalog.
  - a. Select **Configuration and Service** → **Hardware** → **Tape Devices** → **Tape Image Catalogs**.
  - b. Right-click the image catalog and select **Add Volume**.
  - c. Enter the following values:
    - From tape image file: New volume
    - To tape image file: VOL001
    - Volume name (on the Options tab): VOL001
  - d. Click **OK**.
5. Load the image catalog on to the virtual device.
  - a. Select **Configuration and Service** → **Hardware** → **Tape Devices** **Tape Image Catalogs**.
  - a. Right-click the image catalog and select **Load Image Catalog**.
  - b. Click the drop-down arrow on the Tape Device parameter and select the tape device (for example, **TAPVRT01**).
  - c. Click **OK**.
6. Virtual tape storage is ready for operation.
 

Use the virtual tape device as the backup device.

## Setting up virtual tape through 5250 emulation

Here are the basic commands for setting up virtual tape through 5250 emulation:

1. To create a virtual tape device:
 

```
CRTDEVTAP DEVD(TAPVRT01) RSRcname(*VRT)
```
2. To vary on the virtual tape device:
 

```
VRYCFG CFGOBJ(TAPVRT01) CFGTYPE(*DEV) STATUS(*ON)
```
3. To create a virtual tape image catalog:
 

```
CRTIMGCLG IMGCLG(backup) DIR('/images/tape/backup') TYPE(*TAP) CRTDIR(*YES)
```
4. To create virtual images in the image catalog:
 

```
ADDIMGCLGE IMGCLG(BACKUP) FROMFILE(*NEW) TOFILE(VOL001) VOLNAM(VOL001)
```

Repeat for as many volumes as needed.
5. To load the image catalog on to the virtual device:
 

```
LODIMGCLG IMGCLG(backup) DEV(TAPVRT01)
```

The virtual tape storage is ready for operation:

TAPVRT01 is used as the device (DEV) parameter.

## Additional steps for BRMS

If you are using Backup Recovery and Media Services 5722BR1, you have to perform the following additional steps to incorporate virtual tape into your BRMS environment.

1. Add location.

We recommend that you add a location such as VIRTUAL for your virtual media by performing the following tasks:

- a. Enter the following command, and press Enter:

```
WRKLOCBRM
```

- b. Select **1=Add**.

- c. Change values, if any.

2. Add virtual devices.

- To do this manually:

- i. Enter the following command:

```
WRKDEVBRM
```

- ii. Select **1=Add**.

- iii. Change location to virtual media location.

- iv. Change other values, if necessary.

- v. Repeat for additional devices, if any.

- To do this automatically, enter the following:

```
INZBRM OPTION(*DEVICE)
```

This adds all the new devices into BRMS. This also resets the default values for system-supplied devices, if any.

3. Create media class.

Create a media class with the density of your virtual volume.

- a. Enter the following command and press Enter:

```
WRKCLSBRM
```

- b. Select option **1** and add a new media class.

- c. Use the density compatible with your virtual volumes, for example, \*VRT256K.

- d. Enter any other desired values.

4. Add volumes.

Enter the following command:

```
ADDMEDBRM VOL(VOL001) MEDCLS(VRT256K) IMGCLG(Backup) LOC(VIRTUAL)
```

Repeat this step for each volume.

5. Move policy.

Create a move policy, if required.

a. Enter the following command and press Enter:

```
WRKPCYBRM
```

b. Select option **1** and specify a move policy.

c. Enter the values.

6. Create media policy.

Create a media policy with your move policy, media class and storage location.

a. Enter the following command:

```
INZBRM OPTION(*DEVICE)
```

b. Select option **1** and specify a media policy name.

c. Enter the correct move policy, media class, storage location, and other desired parameters.

7. Create control group.

Create a control group with your virtual tape device and media policy if required.



# Related publications

The publications listed in this section are considered particularly suitable for a more detailed discussion of the topics covered in this redbook.

## IBM Redbooks

For information about ordering these publications, see “How to get IBM Redbooks” on page 478. Note that some of the documents referenced here may be available in softcopy only.

- ▶ *Integrating Backup Recovery and Media Services and IBM Tivoli Storage Manager on the IBM @server iSeries Server*, SG24-7031
- ▶ *Backup Recovery and Media Services for OS/400: A Practical Approach*, SG24-4840
- ▶ *IBM @server iSeries Independent ASPs: A Guide to Moving Applications to IASPs*, SG24-6802

## Other publications

These publications are also relevant as further information sources:

- ▶ *OS/400 Backup and Recovery V5R3*, SC41-5304
- ▶ *Backup Recovery and Media Services*, SC41-5345
- ▶ *IBM i5 and iSeries System Handbook*, GA19-5846
- ▶ *IBM i5, iSeries, and AS/400e System Builder*, GA24-2155

## Online resources

These Web sites and URLs are also relevant as further information sources:

- ▶ iSeries Information Center, and then navigate to System Management, Backup and Recovery

<http://publib.boulder.ibm.com/infocenter/iseries/v5r4/index.jsp>

## How to get IBM Redbooks

You can search for, view, or download Redbooks, Redpapers, Hints and Tips, draft publications and Additional materials, as well as order hardcopy Redbooks or CD-ROMs, at this Web site:

[ibm.com/redbooks](http://ibm.com/redbooks)

## Help from IBM

IBM Support and downloads

[ibm.com/support](http://ibm.com/support)

IBM Global Services

[ibm.com/services](http://ibm.com/services)

# Index

## A

- Add backup job sch 311
- Add image catalog entry via 5250 emulation 55
- Add image from another directory via 5250 emulation 56
- Add loc COPIED 287
- Add new volume options via Navigator 45
- Add new volume via 5250 emulation 50
- Add new volume via Navigator 47
- Add volume via Navigator 52
- ADDIMGCLGE command 47, 54, 84, 468
- ADDIMGCLGE IMGCLG 143, 149, 175, 281, 465, 473
- Adding loc VIRTUAL 285
- adding new tape drive 427
- ADDMEDBRM Vol 418, 475
- Authorization list 41–42, 126
- Automatic Cartridge Loader (ACL) 61
- Auto-retrieved object 322–323

## B

- Backup finished 311
- Backup policy 306, 308, 310, 316, 336, 340–341, 344–345, 351, 353, 362–365, 378–379, 385, 388, 416, 422–423, 427–429, 431–432, 450
- Backup Recovery and Media Policy 443
- Backup Recovery and Media Service 385–386, 389–390, 403, 405, 409, 430
- Backup strategy 10–11, 23–24, 284, 311
- Backup, Recovery and Media Services (BRMS) 279, 300, 432, 434, 441, 443, 445, 449, 451–453
- backup, restore, maintenance, and so (BRMS) 329–332, 335, 339–340, 342, 344, 353, 356–357, 359, 361, 369–371, 378, 380–383, 385, 388, 394, 400, 404–405, 407–408, 410–411, 414–416, 418–420, 427, 429–430
- backups one 374
- base i5/OS 10, 174, 182
- batch job 5, 62, 145, 156, 315
- block size 5, 48, 50, 91–93, 97, 99, 175–176, 458
- BRM configuration 285–286, 288, 290–292, 294, 296, 298
- BRM1364 296

- BRM40A2 283
- BRMS activity 320, 323
- BRMS maintenance 319–320
- BRMS network 29, 281, 468
  - feature 29
  - other systems 29
  - today 313
- BRMS store 330
- Browse existing volumes 53

## C

- Catalog relationship via 5250 emulation 131
- Catalog Shadowing Diagram 123
- Catalog01 entries size serial-parallel 167
- Catalog02 entries size serial-parallel 168
- Change attr APPLIC01 153
- Change CTLG Attr DAILY 163
- Change volume attributes via 5250 emulation 88
- Change Volume Properties via Navigator 86
- Changing existing device to virtual device 37
- CHGATR OBJ('/MyCatalogDirectory') ATR(\*AL-WSAV) VALUE(\*NO) SUBTREE(\*ALL) 12
- CHGDEVBRM 288
- CHGVAR VAR 464
- command
  - SAV 116
  - SAVSYS 176
  - SBMJOB CMD 168, 316
- Contents frame 3, 10, 17, 20, 22, 24, 27–28
- control group 305, 310
  - DAILY type 311
  - ITSODBSAVE type 452
- corresponding window 96, 110, 117–118
- create CTLG APPLIC01 152
- create CTLG Daily serial-parallel 162
- create ctlg entries 305
- create dependent catalog via 5250 emulation 130
- create dependent catalog via Navigator 125
- create dependent1 via Navigator 127
- create image catalog 191
- create image catalog via 5250 emulation 44
- create image catalog via Navigator 41
- create location 333

- create mov pcy TO\_COPIED 295
- create virtual device via 5250 emulation 38
- create your own media class 292
- CRTDEV TAP DEVD 37, 142, 149, 280, 472–473
- CRTIMGCLG command 19, 43
  - path name 19
- CRTIMGCLG IMGCLG 149, 175, 280, 473
- CRTMEDPCY VIRTUAL 299
- CRTMOVPCY OUTDOOR 297

## D

- data file 95, 106
- Dedicated Service Tools (DST) 16–17, 27
- default value 43, 316, 325, 467, 474
- Density format of physical tape 100
- dependent catalog 47, 121
  - single volume 135
- Dependent catalog volumes via Navigator 128
- Dependent volume 127, 135
- Dependent volumes via 5250 emulation 132
- device description 6, 35–38, 357
- device TAP01 184
- Directory path 41, 51, 75, 472
  - different directory 52
- Directory subtree 117–118
- disk arm 13–16, 21, 23
  - small amount 21
- disk space 11–12, 16, 23, 300, 355
- Display attributes via 5250 emulation 76
- Display Duplicates for PAR 157
- Display duplicates for VIR 158
- Display label for density via Navigator 99
- Display of save/restore information via 5250 emulation 78
- Display output of save/restore information via 5250 emulation 79
- Display sequence via 5250 emulation 101
- Display volume for density via 5250 emulation 101
- Display volume for density via Navigator 98
- Display volume label Options via Navigator 69
- Display volume labels via Navigator 68
- DLTIMGCLG IMGCLG 137–138
- DSP dup for PAR005 170
- Dsp dup vol VIR003 170
- DSPDUPVOL 318
- DSPMEDCLS 291
- DSPTAP for physical volume once copied 186
- DSPTAP using WRKIMGCLG option 11 178

- DSPTAP using WRKIMGCLG, option 11 178
- DSPTAPVOL inf VRT001 (SAVSYS) 179
- DSPTAPVOL inf VRT002 (SAVSYS) 180
- DSPTAPVOL inf VRT003 (SAVSYS) 181
- DSPTAPVOL inf VRT004 (SAVSYS) 182
- Duplicate sequence via 5250 emulation 112
- Duplicate sequence via Navigator 111
- duplicate volume 23, 159, 171, 325–326, 420
- Duplicate volume files tab via Navigator 105
- Duplicate volume general tab via Navigator 103
- Duplicate volume options via Navigator 107
- Duplicate volume via 5250 emulation 110
- Duplicate volume via Navigator 102
- DUPMEDBRM 314
- DUPMEDBRM command 21, 316, 418, 421
  - other useful parameters 420
- DupSts column 312, 317
- DUPTAP command 110, 112, 182
  - TODEV parameter 182
- DUPTAP FROMDEV 110, 183–184
- DUPTAP joblog 184

## E

- e-mail address 332
- emulation session 34–35, 37, 39, 43, 49, 54, 57, 64, 73, 76–77, 82–83, 87, 93, 96, 100, 110, 116, 128, 134, 136, 138, 472
  - existing volume 100
  - Image Catalog Entries window 82–83
  - tape image catalog 43
  - virtual media 87
  - volume information 76
- End of Volume (EOV) 65
- existing volume 46, 51, 53, 91, 95, 100, 462
- Expiration date 65, 108, 315–316, 333, 338, 340
- expiration flag 332, 335, 337

## F

- F11 key 115, 136
- F4 18–19, 36, 38–40, 44, 50, 55–56, 58, 65, 77–78, 88, 97, 101, 110, 112, 117–119, 130, 135, 139, 144, 147, 153, 163, 282, 288, 293, 295, 297, 299, 306, 311, 320, 323–324, 417
- Figure Work with Media showing DupSts on. 312
- file sequence
  - number 77–78, 101, 105, 110, 112, 314
- file sequence number 106
- Files tab 103, 105, 111

First page change CTLG 306  
Format volume general tab via Navigator 94  
Format volume options tab via Navigator 95  
Format volume via Navigator 94  
Fourth screen change CTLG 310

## G

Go Backup 143  
GOTO CMDLBL 464–465  
GUI 431

## H

Help Text shared media 293

## I

i5/OS V5R4 141  
iASP 4, 15–16, 26, 31  
IBM Redbook 471  
    applicable chapters 471  
image catalog 2, 4, 26, 34, 44, 83, 118, 126, 178, 182, 286, 308, 330, 440, 447–448, 464–465, 472  
    basic operations 42, 126  
    Different density types 6  
    existing volume 51  
    IFS directory 43  
    Image catalog entries 7  
    image catalog entry WRKIMGCLGE 114  
    same volume names 29  
    short description 43  
    specific volumes 121  
    tape volumes 468  
    virtual images 473  
    virtual volumes 462  
image catalog directory via 5250 emulation 115  
image catalog directory via Navigator 113  
image catalog entry 6, 50, 177, 466  
    image catalog 6  
Image catalog properties via Navigator 59  
Image Catalogue  
    virtual images 473  
image file 11, 25, 73, 473  
    Display Attributes 75  
    full path 55  
    maximum size 46, 73  
    name 52, 74, 113  
    option 51  
    size 46–47, 84

image size 12, 50, 84, 88  
initialize tape via 5250 emulation 97  
Integrated File System (IFS) 6, 119  
Internal File System (IFS) 344  
INZBRM \*RUNPRDINZ 282  
INZBRM Option 281, 283, 475  
INZTAP command 5  
IPL 16, 19, 26  
iSeries Navigator 11, 34, 83, 102, 279, 472  
    virtual tape 472

## J

job log 178, 418

## L

library QUSRSYS 25, 118  
List dependent volumes via Navigator 127  
List image catalog volumes via Navigator 80  
List volumes for density via Navigator 92  
List volumes via Navigator 60, 67  
Load image catalog via 5250 emulation 58  
Load image catalog via Navigator 57  
LODIMGCLG command 57, 60, 90  
LPI 291, 293  
LTO cartridge 330

## M

Main Storage Dump (MSD) 27  
manual operation 453  
Mark volumes for Duplication 300  
maximum size 7, 84, 175  
    QIC4DC cartridge 175  
Media Class 29, 150, 283, 289–293, 297, 299–300, 314–316, 318, 357, 417, 452, 463, 466–469, 474–475  
media information 307–308, 314–316, 321–322, 369–370, 414, 419–420  
media policy 151, 153, 158, 163, 170, 297–298, 337, 475  
    deal 416  
    name 475  
Mount volumes for initialize 197  
move policy 150, 170, 294–297, 299, 315–316, 320, 333, 335–337, 339–344, 383, 416, 419, 475  
MOVMEDBRM command 295, 319  
MOVMEDBRM MOVPCY 158, 171, 320  
My Text 152

## N

New volume 44–45, 47, 49–51, 95–96, 380, 473  
Next DUPMEDBRM 315  
next screen 165, 299, 301–302, 304–305, 315, 322, 325  
Next screen STRMNTBRM 322  
next stage 296  
next volume 61, 104, 142, 150, 188, 288, 450, 452, 454, 462, 465

## O

offsite place 158, 170  
operating system 353, 357, 371, 380, 400, 452–453  
    device description 357  
    requirement 22  
Options tab 36, 47, 51, 68, 94–95, 103, 107, 473  
Other Limitations (planning) 27  
Output of volume labels via 5250 emulation 77

## P

parallel backup 29–30, 148, 280  
Parameters for adding existing volume 54  
Parameters for create image catalog in Navigator 43  
Performance Considerations 21  
physical device 5, 25, 64, 150, 280, 315  
physical medium 4, 12, 21, 23, 25, 29, 89, 102, 156, 160, 168, 171, 182, 284, 287, 300, 307, 313, 337, 344, 356, 358, 370, 381, 408, 410–411, 413–415, 417, 419  
    image file 25  
    Media policy 417  
physical tape 1–4, 10, 14–15, 23, 28, 45, 48, 50, 58, 89, 97, 100, 102, 110, 113, 142, 184, 187, 323, 330, 344, 354, 370, 374, 378, 400, 408–409, 415  
    block size 97  
    device 4, 142, 281, 472  
    low density format 409  
    media policy deals 416  
    virtual tape 1  
    volume 28, 102, 284  
physical volume 10, 12, 89, 91, 93, 110, 149, 158, 160, 170, 174, 183, 185, 283–284, 294–297, 300, 308, 315, 318, 320, 325, 327, 344, 416, 419  
    media information 308  
    QIC001 419  
    SAVSYS 174–176, 178–179, 182, 186–187

tape labels 185

    useful parameter 308  
Pop-up window 388, 435  
Prepare add loc COPIED 286  
Prepare for parallel backup 149  
print volume information via Navigator 71  
print volume save/restore via Navigator 71  
proper format 91  
PTF 174

## Q

QP1ARCY parallel-parallel 159  
QP1ARCY par-par usedupmed(\*YES) 159  
Quarter Inch Cartridge (QIC) 142, 175  
QUSRBRM file 316, 323  
    current version 316  
    RGZPFM command 323  
QV5R4M0L00.L292 4 179–180, 186

## R

Random Access Cartridge Loader (RACL) 3  
real tape 2, 408  
    device 6  
    dri 291  
    drive 2  
    volume 2, 330, 355, 436  
recovery report 24, 160, 322–323, 326, 419  
Recovery report volumes 326  
Redbooks Web site 478  
    Contact us xi  
reference catalog 131, 135–136  
    dependent catalogs 132  
reference volume 133  
Resource requirement 23  
retention period 335, 355, 414, 416  
Run backup 445  
Run command via Navigator 62

## S

same sequence 161  
same time 356  
    batch jobs 156  
    control groups 308  
    DUPMEDBRM jobs 314  
    same volume 29  
    SCHHST jobs 422  
sample CL source 462

SAV command 116  
 SAV image catalog directory via 5250 emulation 118  
 SAV image file via 5250 emulation 117  
 save image catalog object via 5250 emulation 119  
 save library via Navigator 63  
 savefile or virtual volume  
     Maximum size limit 30  
 Save-While-Active (SWA) 4  
 SAVLIB prompted via 5250 emulation 65  
 SAVLIB prompted via Navigator 64  
 SAVSYS command 176  
 SBMJOB CMD 168, 316  
 second screen change CTLG 307  
 security requirement 25  
 Select Configuration 36, 44, 50, 56, 58, 67–68, 79, 85, 91, 93, 97, 102, 113, 127, 133, 136–137, 472–473  
 select Property 12, 36, 58, 73, 80, 85, 342, 439  
 Select recovery item dup 328  
 Select recovery item nodup 327  
 Sequence number 65, 77–78, 101, 105–106, 110–112, 300, 314, 324, 400, 405  
 sequence number  
     sequence number 400  
 Set Up Backup 144  
 shadowed volume 133–134  
 Shared media \*YES 293  
 Specifying add VIRTUAL 286  
 Standalone iASP 15–16, 19, 31  
 Stand-alone tape devices via Navigator 35  
 Storage ALCSTG 46  
 storage location 285–286, 299, 384, 417, 475  
 STRBKUBRM CTLGRP 153, 163, 311  
 Stream file changed attributes via 5250 emulation 89  
 STRMNTBRM 321  
 STRMNTBRM command 321–322  
 STRRCYBRM 324  
 STRRCYBRM \*RESTORE DUP(\*NO) 160  
 STRRCYBRM \*RESTORE DUP(\*YES) 160  
 STRRCYBRM Option 158–160, 171, 173, 326, 328  
 STRRCYBRM report ser dup(\*yes) 172  
 STRRCYBRM report ser nodup 171  
 STRRCYBRM screen2 325  
 STRRCYBRM ser \*restore dup(\*yes) 174  
 STRRCYBRM ser \*RESTORE nodup 173  
 switchable iASP 4, 13, 15–16, 19–20, 31  
 system ASP 13–17, 21, 23, 26, 122

data loss 15  
 disk failure 14–15  
 virtual images 14  
 System Licensed Internal Code (SLIC) 174–175, 179, 182

## T

Tape Device 3–6, 23, 26–27, 34–36, 38–40, 44, 48, 50, 56, 58–59, 63, 65, 67–68, 79, 85, 90–91, 93, 95–97, 99, 102–104, 108, 113, 123–125, 127, 132–133, 136–137, 175–176, 182, 188, 279–280, 283, 288–289, 304, 333, 357, 436, 446, 453, 462–467, 469, 472–473, 475  
 tape drive 23, 48, 50, 61, 93, 98–99, 107–108, 142, 187, 329, 384, 386, 397–398, 400, 409, 427, 432, 436–437, 439, 443, 446–448, 450, 453–454, 458  
     current position 107–108  
     physical layout 409  
     type 458  
 Tape library  
     individual tape drives 453  
 tape library 10, 23, 27, 150, 352, 356, 381, 411, 453  
 tape loader 411  
 tape volume 44, 47–50, 58, 93, 95, 101, 104, 106–109, 111–112, 329–330, 451, 468  
     data files 106  
 TCP/IP server 310, 422, 424  
 Third screen change CTLG 309  
 TSM server 325, 453  
 Type 63B0 34–35, 39  
 Type choice 38, 44, 50, 55–56, 58, 65, 77–78, 88, 97, 101, 110, 112, 117–119, 130, 135, 139, 144–145, 147, 286–287, 293, 295, 297, 299, 302–303, 311, 314–315, 321–322, 324–325, 469  
 Type information 152–153, 162–163, 305–307, 309–310  
 Type option 18–19, 36, 39–40, 61, 74–75, 83, 93, 115–116, 129, 131–132, 137, 146, 154, 157, 160, 164–166, 169, 173–174, 177, 285–286, 288, 290–292, 294, 296, 298, 301, 304, 312–313, 317–319, 327–328

## U

Unload Image Catalog via Navigator 125  
 Unsupported command 26  
 user ASP 13–16, 23  
 user Asp 4, 10, 15–17, 19, 26, 29, 31  
     tape images 17

- virtual images 14
- user data 182, 303–304, 346–348, 351
  - daily backup 304
- User Defined File System (UDFS) 17–18, 26, 31

## V

- Vary on virtual tape device via Navigator 38
- Verify catalog status via 5250 emulation 61
- Verify status via 5250 emulation 129
- virtual device 6, 27, 34–38, 56, 58, 60, 64, 120, 122, 132, 142, 149–150, 153, 163, 175, 283, 287, 329, 465, 473
  - image catalog 34
  - maximum number 27
- virtual environment 2, 329–330, 354, 374, 400, 449, 453, 455
- Virtual tape
  - drive 2, 21, 330, 356, 428
  - drive TAPVRT01 288
  - storage 33–34, 176, 473
- virtual tape 1–6, 9–15, 19–31, 33–34, 36, 38–39, 44–45, 47–50, 58, 61–62, 64–65, 89–91, 95, 102, 104, 110, 112, 119, 141–142, 144, 149, 174–176, 182, 187, 279–281, 283–284, 288, 300, 329, 431–432, 439, 447–448, 453, 463–464, 466–467, 471
  - Benefits 1
  - image catalog 6
  - media errors 4
  - required space 30
  - used density 5
- virtual tape device 27
- virtual tape scenarios 141
- Virtual Tape Server (VTS) 2
- virtual tape volume 14–17, 20, 25–28, 31, 329–330
- virtual volume 5–7, 12–13, 16, 19, 21, 23, 27, 29, 45, 48, 51, 54, 73, 75, 84–85, 87, 91–93, 102, 110, 112–113, 133, 153, 155–160, 163–165, 167–171, 173–176, 182, 185–187, 279–280, 283–284, 286–287, 289, 295–296, 299–300, 303, 307–308, 311, 313, 316, 318, 320, 325, 328, 330, 332–335, 337–339, 342–343, 352, 355–356, 358, 369–370, 374, 378, 381, 384, 389, 397, 400, 408–409, 415, 418–419, 436, 443, 461–462, 464, 468, 474
  - allocated size 85
  - default location 468
  - extra space 85
  - home location 284

- move policy 296
- Virtual volume density via 5250 emulation 93
- Virtual volume density via Navigator 92
- Volume added after dependent created 124
- Volume characteristics via 5250 emulation 83
- Volume file name via 5250 emulation 116
- Volume file name via Navigator 114
- Volume identifier 65–66, 77–78, 95–97, 101, 103–104, 110, 314–315
- volume identifier
  - VOL parameter 315
- volume label 48, 69, 95–96, 104
- Volume labels via 5250 emulation 77
- Volume Labels via Navigator 70
- Volume name 29, 47, 50, 52, 61, 67, 74–75, 83, 93, 95, 104, 113–115, 132, 142, 281, 410, 463, 466–468
  - first 3 characters 466
- Volume properties selected via Navigator 80
- Volume Properties via Navigator 81
- Volume save/restore output via Navigator 72
- volume V32K06 441–443
- volume VIR003 158, 170
- volume VIR004 155, 167
  - serial set 155, 167
- Volumes additional information via 5250 emulation 75
- VRFCFG CFGOBJ 39, 142, 149, 175, 280, 464, 473

## W

- welcome window 379
- Work with configuration status via 5250 emulation 40
- Work with lists 301
- Work with serial set 155
- Work with serial set VIR 155
- Work with tape devices via 5250 emulation 36, 39
- Work with virtual volumes via 5250 emulation 74
- WRKCLSBRM 290
- WRKCTLGBRM 304
- WRKDEVBRM 288
- WRKIMGCLG 156
- WRKIMGCLG (SAVSYS) 177
- WRKIMGCLG ,F11 catalog01 155
- WRKIMGCLG ,F11 (SAVSYS) 177
- WRKIMGCLGE command 73, 90, 128
- WRKMEDBRM after DUP 317

WRKMEDBRM after DUP serial 169  
WRKMEDBRM after DUPMEDBRM 157  
WRKMEDBRM DAILY no dup 164  
WRKMEDBRM F11 No dup 165  
WRKMEDBRM PAR\* VIR\* 154  
WRKMEDBRM ser-par no Dup 164  
WRKMEDBRM show physical out 319  
WRKMEDBRM show vol and more 318  
WRKMEDBRM showing backup set 313  
WRKMEDBRM window 154, 169  
WRKMOVPCY add phys vol 296  
WRKPCYBRM \*MED 298  
WRKPCYBRM \*MOV 294

## **X**

xSeries server 3





**Redbooks**

# i5/OS V5R4 Virtual Tape: A Guide to Planning and Implementation

(1.0" spine)  
0.875" <-> 1.498"  
460 <-> 788 pages







**Redbooks**

# i5/OS V5R4 Virtual Tape: A Guide to Planning and Implementation

## **Discover how i5/OS virtual tape works**

In this IBM Redbook we provide a detailed explanation of the new virtual tape support provided by i5/OS V5R4. We cover the concepts, planning, and use of virtual tape support.

## **Learn how to save and restore objects with virtual tape support**

Backup and Recovery Media Services (BRMS) is an important program product for System i5 customers to enable management of their system and data backups. This publication describes how BRMS uses the new virtual tape support for virtual backups.

## **Understand how virtual tape works with BRMS**

This redbook is intended for IBM, Business Partner and customer technical professionals who will be planning, implementing, and operating virtual tape support.

## **INTERNATIONAL TECHNICAL SUPPORT ORGANIZATION**

## **BUILDING TECHNICAL INFORMATION BASED ON PRACTICAL EXPERIENCE**

IBM Redbooks are developed by the IBM International Technical Support Organization. Experts from IBM, Customers and Partners from around the world create timely technical information based on realistic scenarios. Specific recommendations are provided to help you implement IT solutions more effectively in your environment.

**For more information:**  
[ibm.com/redbooks](http://ibm.com/redbooks)